

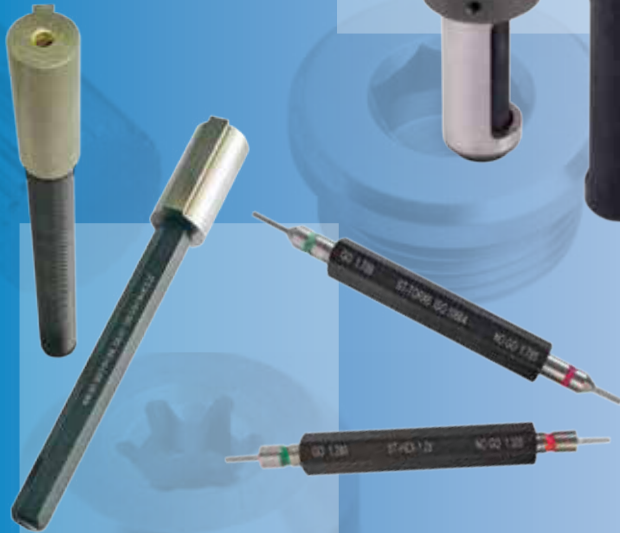

BRIGHETTI MECCANICA
Made in Italy



CATALOGO GENERALE 10^a edizione
GENERAL CATALOGUE 10th edition



Indice

Table of contents

| | |
|---|-----------|
| L'AZIENDA / THE COMPANY | 4 |
| CONDIZIONI GENERALI DI VENDITA / GENERAL TERMS OF SALE | 4 |
| SISTEMI DI BROCCIATURA / BROACHING SYSTEMS | 5 |
| Brocciatori Standard serie "BR" / <i>Standard Broaching Heads "BR" series</i> | 6 |
| Brocciatori con passaggio refrigerante interno serie "BRC" / <i>Broaching Heads with internal flow of coolant "BRC" series</i> | 7 |
| Brocciatori serie "BR" e BRC - Descrizione / <i>Broaching Heads "BR" and "BRC" Series - Description</i> | 8 |
| Brocciatori serie "BR" e "BRC" - Codifica delle sigle / <i>Broaching Heads "BR" and "BRC" Series - Item codes</i> | 9 |
| Brocciatori Standard serie "BR" - Caratteristiche tecniche e dimensioni / <i>Standard Broaching Heads "BR" series - Technical characteristics and dimensions</i> | 10 |
| Brocciatori con passaggio refrigerante interno serie "BRC" - Caratteristiche tecniche e dimensioni / <i>Broaching Heads with internal flow of coolant "BRC" series - Technical characteristics and dimensions</i> | 11 |
| Brocciatore registrabile serie "BR" - Caratteristiche / <i>Adjustable Broaching Head "BR" series - Technical characteristics and dimensions</i> | 12 |
| BROCCIE PER CAVE POLIGONALI SU BROCCIATORI SERIE "BR" E "BRC" / BROACHES FOR POLYGONAL HOLES ON BROACHING HEADS "BR" AND "BRC" SERIES | 14 |
| Pre-foro per brocciatura dei profili: Esagonali, Quadri, TORX® e TORX® PLUS / <i>Pre-hole Broaching: Exagonal, Square, TORX® and TORX® PLUS</i> | 15 |
| Smussi per brocciatura profili esagonali, quadri, Torx® / <i>Chamfer broaching: exagonal, square, Torx®</i> | 16 |
| Parametri di utilizzo per le lavorazioni delle brocche in hss e sinterizzato / <i>Working parameters for broach machining made of hss and sintered material</i> | 17 |
| Rivestimenti per brocche / <i>Coatings for broaches</i> | 18 |
| Brocche per cave poligonali - Misure metriche / <i>Standard broaches for polygonal holes - Sizes in mm</i> | 19 |
| Brocche per cave poligonali - Misure in pollici / <i>Standard broaches for polygonal holes - Sizes in inches</i> | 37 |
| Brocche standard e con passaggio refrigerante per chiavi TORX® (*) / <i>Standard Broaches and with internal flow of coolant for TORX® wrenches (*)</i> | 45 |
| Brocche standard e con passaggio refrigerante per chiavi TORX® PLUS (*) / <i>Standard Broaches and with internal flow of coolant for TORX® PLUS wrenches (*)</i> | 47 |
| BROCCIE PER PROFILI ESTERNI / SURFACE BROACHES | 49 |
| BROCCIE SPECIALI PER PER PROFILI INTERNI-ESTERNI / SPECIAL BROACHES FOR INNER-OUTER PROFILES | 50 |
| Brocche speciali per profili dentati / <i>Special broaches for toothed profiles</i> | 51 |
| Brocche speciali derivate dalle brocche STD / <i>STD derived special broaches</i> | 51 |
| Brocche speciali per viti antimanomissione / <i>Special broaches for anti-tamper screws</i> | 51 |
| Mini fresa a carotare per cava viti antimanomissione / <i>Mini milling core drilling for anti tampering screws</i> | 51 |
| CALIBRI E TAMPONI DI CONTROLLO G/NG PER FORI POLIGONALI E SEDI CHIAVETTE / G/NG CHECK GAUGES AND BUFFERS FOR POLYGONAL PROFILE AND FOR KEYWAY SLOTS | 52 |
| BT/BTA SISTEMA DI BROCCIATURA SEDE DI CHIAVETTA DI TRASCINAMENTO SU MACCHINE CNC / BT/BTA INTERNAL KEYWAY BROACHING SYSTEM ON CNC MACHINE TOOLS | 56 |
| Inseri in Acciaio Sinterizzato per sedi chiavette: misure metriche e in pollici (IN) / <i>Sintered steel inserts for keyway seats: metric and inches size (IN)</i> | 58 |
| Inseri in Metallo Duro per sedi chiavette: misure metriche e in pollici (INHM) / <i>Hard metal inserts for keyway seats: metric size (INHM)</i> | 59 |
| UTENSILI PER MACCHINE A CONTROLLO / TOOLS FOR CNC MACHINES | 60 |
| Porta-insero per sedi di chiavette interne (UT) / <i>Insert holder for internal keyways (UT)</i> | 60 |
| Inseri per profili quadri ed esagonali interni (IN-SQ, IN-HEX) / <i>Inserts for internal squares and hexagons profiles (IN-SQ, IN-HEX)</i> | 61 |
| Porta-insero per profili quadri ed esagonali interni (UT-SQ, UT-HEX) / <i>Insert holder for internal squares and hexagons profiles (UT-SQ, UT-HEX)</i> | 61 |
| Utensili per profili scanalati (UTS) / <i>Tools for splined profiles (UTS)</i> | 63 |
| Porta-insero per profili esterni (UTE) / <i>Insert holder for external profiles (UTE)</i> | 63 |
| Bussole eccentriche (B) / <i>Eccentric bush (B)</i> | 64 |
| Allineatori per fresatrici / <i>Alignment plates for milling machines</i> | 65 |
| Flessibilità del sistema e tempi di esecuzione lavoro / <i>System flexibility and machining time</i> | 65 |
| Programmazione macchina CNC / <i>CNC machine tool programming</i> | 65 |
| Velocità di taglio e incremento di taglio da un passaggio al successivo / <i>Cutting speed and cutting increase hit by hit</i> | 66 |



| | |
|---|-----------|
| UTENSILE PER INTERNO: MINITOOL / TOOL FOR INTERIOR: MINITOOL | 67 |
| UTENSILI PER MACCHINE STOZZATRICI / TOOLS FOR SLOTTING MACHINES | 68 |
| Adattatori per macchine stozzatrici / <i>Adaptors for slotting machines</i> | 68 |
| Porta inserti monotaglianti per macchine stozzatrici / <i>One cutting edge holder for slotting machines</i> | 68 |
| Inserti in Metallo Duro misure metriche e in pollici (INHM) / <i>Hard metal inserts metric size (INHM)</i> | 69 |
| Inserti doppio tagliente / <i>Double cutting edge inserts</i> | 69 |
| Porta inserti doppio tagliente per macchine stozzatrici / <i>Double cutting edge holder for slotting machines</i> | 69 |
| STOZZATORE MOTORIZZATO / MOTORIZED SLOTTING HEAD | 70 |
| Caratteristiche e versioni (ST-25, ST-35, ST-50, ST-65) / <i>Features and versions (ST-25, ST-35, ST-50, ST-65)</i> | 70 |
| Porta-inserto (serie UTM, UTM-HEX, UTM-SQ) / <i>Insert holder (series UTM, UTM-HEX, UTM-SQ)</i> | 71 |
| Programmazione macchina e Parametri di taglio / <i>Machine tool programming and Cutting parameters</i> | 72 |
| VALIGETTE KIT / TOOL BOX KITS | 73 |
| BUSSOLE DI RIDUZIONE / REDUCTION BUSHES | 74 |
| Bussole cilindriche / <i>Cylindrical bushes</i> | 75 |
| Bussole coniche / <i>Conical bushes</i> | 79 |
| Bussole con passaggio del refrigerante / <i>Bushes with flow of cooling liquid</i> | 80 |
| Bussole elastiche / <i>Elastic bushes</i> | 80 |
| Bussole elastiche per barre antivibranti / <i>Elastic bushes for vibration damper bars</i> | 81 |
| Bussole speciali - Disegno per ordini di bussole speciali / <i>Special bushes - Technical drawing for ordering special bushes</i> | 82 |
| BRIDE DI TRASCINAMENTO / GRINDING CARRIERS | 83 |
| Bride in acciaio / <i>Grinding carriers in steel</i> | 83 |
| Bride in alluminio / <i>Grinding carriers in aluminium</i> | 84 |
| Leve per Bride / <i>Lever for Grinding carriers</i> | 84 |
| Molle per Bride / <i>Springs for Grinding carriers</i> | 84 |

(*) Marchio registrato da TEXTRON Inc. - Providence (USA) / (*) Trade Mark by TEXTRON Inc. - Providence (USA)

SCANSIONA IL QR CODE CON I TUOI DISPOSITIVI E
SCARICA IL CATALOGO BRIGHETTI MECCANICA

SCAN THE QR CODE BY YOUR DEVICES AND DOWNLOAD
THE BRIGHETTI MECCANICA CATALOGUE



<https://bit.ly/4bq9NID>



SCANSIONA IL QR CODE CON I TUOI DISPOSITIVI
E SCOPRI LA BRIGHETTI MECCANICA

SCAN THE QR CODE BY YOUR DEVICES AND DISCOVER
BRIGHETTI MECCANICA

ITA

UK

<https://bit.ly/3UvfAqr>
<https://bit.ly/3Snq6gE>

I La BRIGHETTI MECCANICA s.r.l. nasce nel 1972 come azienda produttrice di minuterie meccaniche nel settore della Moda.

Agli inizi degli anni 80 compie un salto qualitativo ed entra nel settore degli attrezzi per macchine utensili tradizionali e a controllo numerico.

Negli oltre trent'anni di attività la BRIGHETTI MECCANICA s.r.l. si è distinta per la elevata qualità dei suoi prodotti ed ha sempre profuso il massimo impegno, sotto il profilo sia tecnico che commerciale, per soddisfare puntualmente le richieste della propria clientela.

La BRIGHETTI MECCANICA s.r.l. si distingue inoltre per la rapidità delle consegne: infatti gli ordini relativi ad articoli codificati nel presente Catalogo Generale vengono evasi entro il giorno successivo al ricevimento dell'ordine, in quanto tutti gli articoli sono presenti a magazzino, salvo il venduto.

Il ciclo di produzione si svolge in Italia, per cui la nostra produzione è tutta rigorosamente "Made in Italy".

I nostri prodotti

La gamma dei nostri prodotti comprende:

- > Brocciatori standard e serie BRC (con passaggio frigerante)
- > Brocche per cave poligonali (serie BR e serie BRC), per profili esterni e speciali, nelle misure metriche e in pollici
- > Brocche per chiavi TORX® e TORX® PLUS
- > Tamponi di controllo per profili poligonali interni, esterni e per sedi di chiavette
- > BT/BTA – Sistema di brocciatura sede per chiavette su CNC
- > Valigette
- > Bussole di riduzione
- > Bride di trascinamento

Oltre agli articoli standard presentati nel Catalogo Generale, BRIGHETTI MECCANICA s.r.l. è in grado di costruire particolari sulla base delle specifiche richieste tecniche del Cliente. Ogni nostro prodotto è sottoposto ad un opportuno trattamento termico e, se richiesto, a diversi tipi di rivestimento.

GB BRIGHETTI MECCANICA s.r.l. was established in 1972 as a manufacturer of small metallic items for the Fashion Industry. At the beginning of the 1980s, it took a major step forward by launching the production of components for conventional and numerically controlled machine tools.

In over thirty years of business, BRIGHETTI MECCANICA s.r.l. has earned a reputation for the high quality of its products and has always been firmly committed to promptly satisfying Customer's demands of both, a commercial and technical nature.

From a commercial point of view, BRIGHETTI MECCANICA s.r.l. stands out for fast deliveries: orders for the standard items included in this Catalogue are carried out the day after the order is received, as the whole range of products is available in stock.

All production processes take place in Italy, for this reason the entire production is to be considered "Made in Italy".

Our products:

The products range includes:

- > Standard Broaching heads and BRC series (with internal flow of coolant)
- > Broaches for polygonal holes (BR and BRC series), surface broaches and special broaches, in metric and inch sizes
- > Broaches for TORX® and TORX® PLUS wrenches
- > Plug Gauges for internal and external polygonal profile and for keyway slots
- > BT/BTA – Internal keyway broaching system on CNC
- > Tool box kits
- > Reduction bushes or reduction sleeves
- > Grinding carriers in aluminium

In addition to the standard items featured in its Catalogue, BRIGHETTI MECCANICA s.r.l. can build special parts on the basis of Customer's specifications. All products undergo suitable heat treatments, according to type.

Condizioni generali di vendita

General terms of sale

I Gli ordini vengono considerati validi solo se fatti per iscritto con la precisa indicazione del codice articolo, della quantità, della data di consegna richiesta e del trasporto.

Per ordini di quantità elevate la data di consegna deve essere preventivamente concordata.

La merce viaggia a rischio e pericolo del Committente anche se venduta franco addebito. Non si accettano reclami trascorsi otto giorni dal ricevimento della merce. I pagamenti sono validi solo se fatti direttamente alla BRIGHETTI MECCANICA s.r.l. Non sono accettati arrotondamenti o sconti ancorché non concordati.

I ritardati pagamenti fanno decorrere gli interessi commerciali di mora. Per ogni controversia è competente l'Autorità Giudiziaria di Bologna.

Nota

I dati e le caratteristiche tecniche riportati nel presente Catalogo Generale possono subire delle modifiche senza preavviso

GB Orders will be considered valid only if submitted in writing, with a precise indication of the item code, quantity, delivery date and means of transport. In the case of large orders, the delivery date must be arranged in advance. The Customer will bear all the transport risks, even if the goods are delivered carriage pre-paid, with shipping charges to be debited in the sales invoice.

No claims will be accepted unless submitted within eight days of the receipt of the goods. Payments must be made directly to BRIGHETTI MECCANICA s.r.l.. No rounding off or discount will be allowed unless previously agreed on.

Interests will be charged on delayed payments, according to current Bank rates. The Court of Bologna will have sole jurisdiction in any action arising from a dispute.

Note

The technical features contained in this General Catalogue can be modified with no previous notice.



Sistemi di Brocciatura

Broaching Systems

Brocciatori Standard serie "BR"

Standard Broaching Heads "BR" series



pag. 6

Brocciatori Regolabili serie "BR"

Adjustable Broaching Heads "BR" series



pag. 12

Brocciatori con passaggio refrigerante interno serie "BRC"

Broaching Heads with internal flow of coolant "BRC" series



pag. 7

BREVETTO
DEPOSITATO

I I Brocciatori Standard **serie "BR"** e i Brocciatori con passaggio refrigerante **serie "BRC"** sono attrezzi per l'esecuzione rapida di cave poligonali a sezione regolare (quadra, esagonale, Torx®, Torx®Plus, dentata, scanalata ecc.) in fori ciechi o passanti. Inoltre, con l'ausilio dell'adattatore, sullo stesso brocciatore si possono realizzare profili esterni a sezione regolare.

GB *The Standard Broaching Heads "BR" series and the Broaching heads with internal flow of coolant "BRC" series are a high-speed tool for forming blind or through holes with regular polygonal shapes (square, hexagonal, Torx®, Torx®Plus, spline, etc.). Installing an adaptor on the same broaching head, polygonal surface profiles can be realized.*



Brocciatori Standard serie "BR"

Standard Broaching Heads "BR" series



I Il Brocciatore è un attrezzo per l'esecuzione rapida di cave poligonali a sezione regolare (quadra, esagonale, TORX®, dentata, scanalata, ecc.) in fori ciechi o passanti. Inoltre, con l'ausilio dell'adattatore, sullo stesso brocciatore si possono realizzare profili esterni a sezione regolare.

Il brocciatore può essere applicato sulla maggior parte delle macchine utensili con moto rotatorio, sia tradizionali (tornio, trapano, fresa) che a controllo numerico, quindi può lavorare sia in verticale che in orizzontale.

Il perno portabrocce è montato all'interno del corpo con una determinata inclinazione e, quando viene messo in rotazione dalla macchina utensile, conferisce alla broccia stessa un movimento rotatorio e pendolare. L'azione combinata della rotazione, dell'avanzamento forniti dalla macchina e dal movimento pendolare, permettono alla broccia di penetrare dolcemente nel pezzo da lavorare, a cui è stato precedentemente eseguito un preforo, creando così il profilo desiderato.

GB The Broaching Head is a high-speed tool for forming blind or through holes with regular polygonal shapes (square, hexagonal, TORX®, spline, etc.). Installing an adaptor on the same broaching head, polygonal surface profiles can be realized.

The broaching head may be applied on most rotary machine tools, both conventional (lathe, drill, milling machine) and numerically controlled ones. Thus it can work both vertically and horizontally.

The broach seat is set in the tool body at a specific inclination so that, when the machine rod starts to rotate, it transmits both, a rotary and oscillating motion to the broach. The combined action deriving from the rotation and feed function provided by the machine, allows the broach to smoothly penetrate the pre-drilled work-piece, in order to form the shape required.

**SCANSIONA IL QR CODE CON I TUOI DISPOSITIVI
E SCOPRI I NOSTRI BROCCIATORI "BR"**

SCAN THE QR CODE BY YOUR DEVICES AND DISCOVER
THE VIDEO ABOUT "BR" BROACHING HEADS

IT

<https://bit.ly/3OtS1tZ>

GB

<https://bit.ly/49nhaic>

**SCANSIONA IL QR CODE CON I TUOI DISPOSITIVI
E SCOPRI I NOSTRI BROCCIATORI "BRC"**

SCAN THE QR CODE BY YOUR DEVICES AND DISCOVER
THE VIDEO ABOUT "BRC" BROACHING HEADS

IT

<https://bit.ly/3w8JlLF>

GB

<https://bit.ly/3OyAocG>



Brocciatori con passaggio refrigerante interno serie "BRC"

Broaching Heads with internal flow of coolant "BRC" series

L'EVOLUZIONE NASCE DA DENTRO

THE EVOLUTION COMES OUT FROM THE INSIDE



I Il nuovo brocciatore serie "BRC" è stato sviluppato con le medesime caratteristiche di funzionamento dell'analogo brocciatore BM, con la differenza che al suo interno sono state apportate modifiche che permettono di convogliare i liquidi lubrorefrigeranti e/o aria compressa dalla parte posteriore del codolo di attacco verso la punta estrema della broccia. **Il liquido lubrorefrigerante fuoriesce dalla broccia da due diverse posizioni ed esattamente:**

- 1) Da due fori inclinati, posizionati in testa alla broccia, che consentono di irrorare di liquido lubrorefrigerante e/o aria compressa l'intera zona interna del tagliente sul punto esatto in cui avviene la fase di brocciatura.
- 2) Da due fori laterali, sempre inclinati, posizionati sulla rastremazione del mozzo della broccia con la funzione di scaricare parzialmente la pressione del liquido lubrorefrigerante e/o aria compressa.

I vantaggi dell'uso del brocciatore "BRC" sono molteplici:

- 1) il filo tagliente della broccia si preserva più a lungo assicurando una maggiore durata della vita media della broccia, con una valutazione obiettiva che varia dal 15 al 22% di maggior durata del tagliente in relazione al tipo di materiale da brocciare
- 2) la cava interna, con l'ausilio del liquido lubrorefrigerante e/o aria compressa, presenta una migliore lucentezza delle superfici con una rugosità che si attesta intorno al valore di Ra 0.5
- 3) l'impiego del brocciatore BRC è consigliabile per tutti i tipi di materiali, ma nello specifico per:
 - a) Il titanio e l'acciaio inox, in cui avviene, durante la lavorazione, un notevole aumento di temperatura a causa della tenacità dei materiali stessi.
 - b) Materiali con alto contenuto di magnesio, che a causa della loro proprietà di autocombustione potrebbero dare adito ad un principio di incendio della macchina utensile. In questi casi è consigliabile l'uso di aria compressa come refrigerante.
 - c) In generale materiali particolarmente tenaci, in cui il truciolo presenta difficoltà nello staccarsi dalle pareti.
 - d) La ghisa, il bronzo e alcune leghe di alluminio producono trucioli con effetto polvere.
 - e) Altre leghe di alluminio e la plastica, producono un truciolo che tende "ad incollarsi alla broccia"

L'utilizzo del lubrorefrigerante può essere anche sostituito da aria compressa, utilizzando un raccordo e collegando un tubo di Rilsan e/o di rame direttamente sul codolo posteriore, il quale, integra un filetto da G1/8", lo stesso foro, può essere chiuso tramite tappo a corredo per omettere il passaggio del lubrorefrigerante e/o aria compressa e quindi si può utilizzare il brocciatore Brighetti Meccanica BRC come un normale BM con l'uso delle brocche standard.

GB The new "BRC" broaching head has been developed with the same operating characteristics as the similar Brighetti Meccanica BM broaching head, with the difference that modifications have been made inside the tool, which allow conveying the coolants and/or compressed air from the rear of the connection shank towards the extreme tip of the broach.

The coolant comes out of the broach from two different positions, more precisely:

- 1) From two inclined holes, positioned at the head of the broach, which allow the sprinkling of coolant and/or compressed air the whole internal area of the cutting edge at the exact point where the broaching process takes place.
- 2) From two side holes, still inclined, positioned on the tapering of the broach hub with the function of partially releasing the pressure of the coolant and/or compressed air.

Among the many advantages of using the "BRC" broaching head:

- 1) the cutting edge of the broach is preserved, ensuring a longer duration of the average life of the broach, with an objective evaluation ranging from 15 to 22% of greater cutting edge durability depending on the type of material to be broached
- 2) the internal hole, with the aid of coolant and/or compressed air, has a better surface gloss with a roughness which is around the value of Ra 0.5
- 3) the use of the BRC broaching head is recommended for all types of materials, but specifically for:
 - a) Titanium and stainless steel, in which a significant increase of temperature occurs during the machining due to the tenacity of the materials themselves.
 - b) Materials with a high magnesium content which, due to their self-ignition properties, could cause a fire principle of the machine tool. In these cases, it is advisable to use compressed air as coolant.
 - c) In general, particularly tough materials, where the chip shows difficulties in detaching from the walls.
 - d) Cast iron, bronze and some aluminium alloys which produce chips with a dust effect.
 - e) Other aluminium alloys and plastics which produce a chip that tends to "stick to the broach"

The use of coolant may also be replaced by compressed air, using a fitting and connecting a Rilsan and/or copper pipe directly to the rear shank, which integrates a G1/8" thread; the same hole can be closed by means of a cap supplied to prevent the coolant flow and/or compressed air and therefore the Brighetti Meccanica BRC broaching head can be used like a normal BM with the use of standard broaches.



Brocciatori serie "BR" e BRC - Descrizione

Broaching Heads "BR" and "BRC" Series - Description

I I brocciatori sono composti da diversi elementi che sono descritti di seguito.

A - Corpo.

E' costruito in acciaio bonificato e rettificato al cui interno si trovano dei cuscinetti a sfera adatti a sopportare i carichi risultanti dalla lavorazione.

B - Mandrino porta broccia

E' montato all'interno del corpo e ruota sui cuscinetti a sfera presenti all'interno del corpo stesso. Nella parte esterna che sporge dal corpo si trova una vite per il bloccaggio della broccia e un foro filettato per il fissaggio della barretta di trascinamento.

C - Sede innesto broccia

E' costituita da un alloggiamento all'interno del mandrino porta broccia nel quale viene inserita la broccia. Questo alloggiamento viene opportunamente lavorato e rettificato con tolleranza tale da ottenere massima precisione nella lavorazione.

D - Fissaggio alla macchina utensile

Dalla parte opposta al mandrino si trova il codolo per il fissaggio alla macchina utensile, solidale con il corpo. Il brocciatore viene costruito con diversi tipi di codolo per poter essere applicato a una ampia gamma di macchine utensili:

- > codolo cilindrico C
- > codolo cono Morse CM
- > codolo ISO-DIN 69871 / DIN 2080
- > codolo VDI
- > codolo CAPTO ISO-26623

E - Barretta di trascinamento

E' costituita da una barretta d'acciaio, fornita in dotazione, che viene avvitata in un apposito foro presente sul mandrino porta broccia. Per determinate operazioni di brocciatura si consiglia l'uso della barretta di trascinamento; in questo modo si assicura la perfetta linearità della figura durante l'operazione di brocciatura. Inoltre l'impiego della barretta è indispensabile quando il pezzo da lavorare richiede un preciso orientamento della figura da ottenere con la brocciatura. Nel caso di una lavorazione al tornio la barretta deve essere inserita in una forcella presente sul mandrino del tornio stesso; nel caso di una lavorazione con fresa o trapano, la barretta viene bloccata da un'asta applicata sul piano di lavoro.

GB The following parts compose the broaching heads.

A - The body

The body of the broaching head is made of tempered steel. The ball bearings sustaining the machining effort are placed inside the body of the broaching head.

B - Spindle of the broaching head

The spindle holding the broach is placed inside the body of the broaching head and turns on the ball bearings. In its outer part there is a screw used to fasten the broach and a threaded hole to install the drawrod.

C - The broach seat

It is a housing inside the spindle of the broaching head, in which the broach is installed. This housing is properly realized and grinded in order to suit with great precision the shank of the broach.

D - Connection to the machine tool

At the opposite side of the body of the broaching head from the spindle there is the connection to the machine tool. The broaching head is available with several kind of connections in order to be installed on a wide range of machine tools:

- > Cylindrical connection
- > Morse taper connection
- > ISO-DIN 69871 / DIN 2080 connection
- > VDI connection
- > CAPTO ISO-26623 connection

E - Drawrod

It is a little steel bar supplied together with the broaching head and it is to be installed in the special threaded hole on the spindle of the broaching head. It has the purpose to avoid the machining of twisted shapes and it guarantees a particular orientation of the shape in the work piece. If the machine used is a lathe the drawrod must be fixed on the fork of the spindle of the lathe itself, while if the machine used is a milling machine or a drill the drawrod must be fixed on a bar fastened to the working desk.

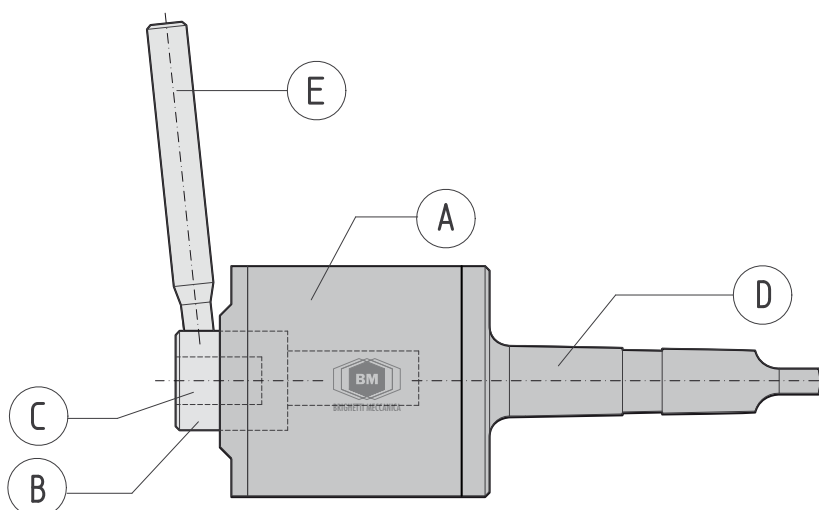



Brocciatori serie "BR" e "BRC" - Codifica delle sigle

Broaching Heads "BR" and "BRC" Series - Item codes

I Come leggere la codifica dei brocciatori BR:
Facciamo un esempio: **BR (o BRC) - G16M - C32**

GB How to read broaching heads item codes.
Let's make an example: **BR (or BRC)- G16M - C32**

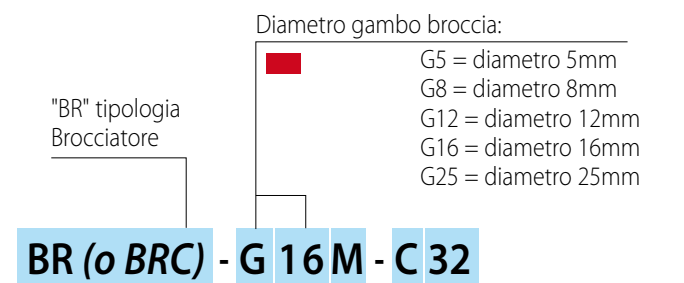

Varianti della dimensione del corpo brocciatore

"S" = SMALL: la quota "H" (fig.1) è stata ridotta fino ad una misura minima tecnicamente consentita

"M" = MEDIUM: la quota "K" (fig.1) è stata ridotta fino al minimo consentito

"B" = le quote "H" e "K" (fig.1) sono state ridotte fino al minimo consentito

"A" = ADJUSTABLE: si tratta di un brocciatore speciale che può eseguire operazioni di brocciatura molto profonde

"L" = potenziamento del modello base per aumentarne le prestazioni in termini di:

- dimensioni broccia
- profondità utile di lavoro
- profondità max. di brocciatura

Misura del Codolo di attacco del brocciatore

Tipologia di Codolo per il fissaggio dello stesso alla macchina utensile

"C" = Cilindrico
"CM" = Cono Morse
"ISO" = ISO DIN-69871/ DIN-2080
"VDI"
"CAP" = CAPTO ISO-26623
"HSK" = a richiesta

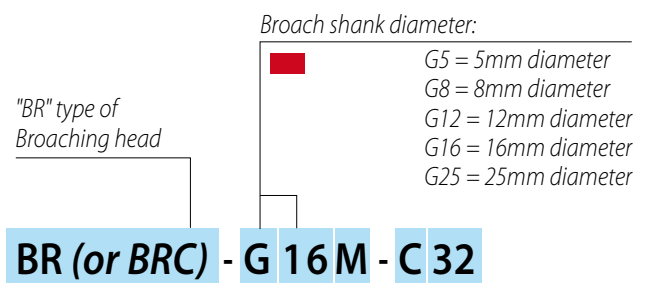

Different versions of the body of the broaching head

"S" = SMALL: size "H" (fig.1) has been reduced to the minimum technically allowed

"M" = MEDIUM: size "K" (fig.1) has been reduced to the minimum technically allowed

"B" = sizes "H" e "K" (fig.1) have been reduced to the minimum technically allowed

"A" = ADJUSTABLE: indicates a special broaching head used for operations at a high depth

"L" = enhancement of the basic model to increase the performances of the head as for:

- size of the broach
- depth of the machining
- depth of the shape

Size of the connection of the head

Type of connection to the machine tool

"C" = Cilindrico
"CM" = Morse taper
"ISO" = ISO DIN-69871/ DIN-2080
"VDI"
"CAP" = CAPTO ISO-26623
"HSK" = on demand

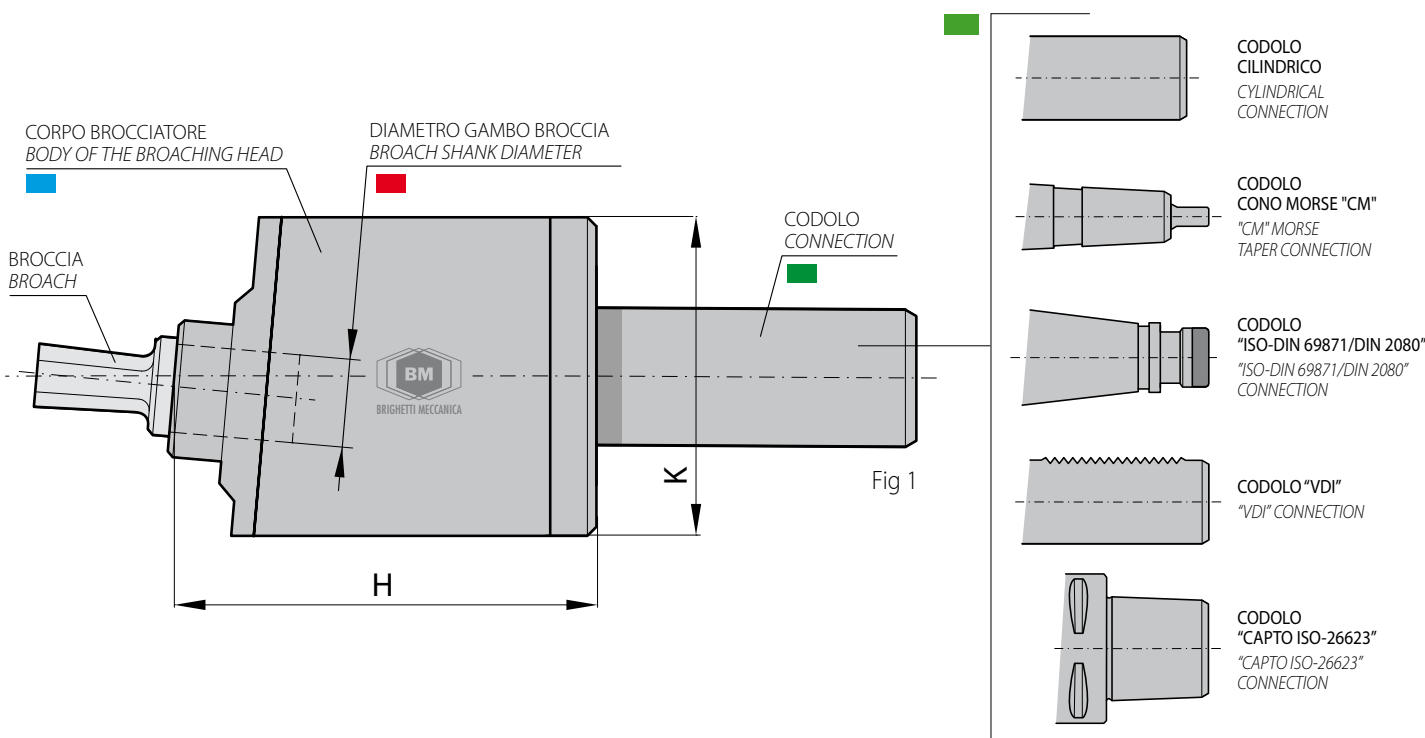



Brocciatori Standard serie "BR"

- Caratteristiche tecniche e dimensioni

Standard Broaching Heads "BR" series

- Technical characteristics and dimensions

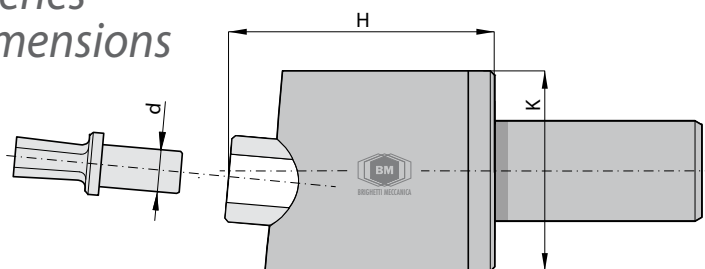

| CARATTERISTICHE / FEATURES | dim. | BROCCIATORE / BROACHING HEAD (BR) | | | | | | | | | | |
|---|------|-----------------------------------|--------|--------|-------|---------|--------|--------|---------|---------|--------|--------------------------|
| | | BR-G5 | BR-G8 | | | BR-G12 | | BR-G16 | | | BR-G25 | |
| | | | BR-G8S | BR-G8M | BR-G8 | BR-G12B | BR-G12 | BR-G16 | BR-G16M | BR-G16L | | |
| GAMBO DELLA BROCCIA SHANK OF THE BROACH | d | mm | Ø5 | Ø8 | Ø8 | Ø8 | Ø12 | Ø12 | Ø16 | Ø16 | Ø16 | Ø25 |
| CAPACITA' CAVE ESAGONALI HEXAGONAL SLOT CAPACITY | | mm | 1÷6 | 1÷8 | 1÷8 | 1÷10 | 1÷13 | 1÷15 | 2÷25 | 5÷30 | 4÷30 | 15÷40 |
| CAPACITA' CAVE QUADRE SQUARE SLOT CAPACITY | | mm | 1÷4 | 1÷6 | 1÷6 | 1÷8 | 1÷10 | 1÷12 | 2÷15 | 5÷20 | 4÷25 | 15÷25 |
| CAPACITA' CAVE TORX® TORX® SLOT CAPACITY | T | | 3÷25 | 3÷40 | 3÷40 | 3÷40 | 3÷60 | 3÷60 | 10÷70 | 20÷70 | 30÷70 | a richiesta on demand |
| CAPACITA' CAVE TORX® PLUS TORX® PLUS SLOT CAPACITY | IP | | 6÷25 | 6÷40 | 6÷40 | 6÷40 | 6÷60 | 6÷60 | 10÷70 | 20÷70 | 30÷70 | a richiesta on demand |
| PROFONDITA' MAX DI LAVORO MAXIMUM WORKING DEPTH | | mm | 7,5 | 15 | 15 | 15 | 21 | 21 | 21 | 30 | 40 | 65 |
| DIMENSIONE CORPO BODY DIMENSIONS | H | mm | 35 | 36,5 | 47,5 | 55 | 66,5 | 81,5 | 87 | 91 | 99 | 115,5 |
| DIMENSIONE CORPO BODY DIMENSIONS | K | mm | Ø22 | Ø37 | Ø29,5 | Ø37 | Ø47 | Ø58 | Ø68 | Ø68 | Ø79 | Ø91 |
| PESO (indicativo) WEIGHT (indicative) | | gr. | 181 | 412 | 338 | 525 | 851 | 1653 | 2628 | 1830 | 3500 | 4850 |

| TIPO DI ATTACCO / CONNECTIONS | BROCCIATORE / BROACHING HEAD (BR) | | | | | | | | | | |
|--|-----------------------------------|-------|--------|--------|-------|---------|--------|--------|---------|---------|--------|
| | | BR-G5 | BR-G8 | | | BR-G12 | | BR-G16 | | | BR-G25 |
| | | | BR-G8S | BR-G8M | BR-G8 | BR-G12B | BR-G12 | BR-G16 | BR-G16M | BR-G16L | |
| CODOLO CILINDRICO CYLINDRICAL CONNECTION | Ø | 8 | 10 | 10 | 10 | 16 | 20 | 25 | 25 | 25 | 32 |
| | Ø | 10 | 12 | 12 | 12 | 19,05 | 25 | 32 | 32 | 32 | 40 |
| | Ø | 12 | 16 | 16 | 16 | 20 | 32 | 40 | 40 | 40 | |
| | Ø | 16 | 19,05 | 19,05 | 19,05 | 22 | | | | | |
| | Ø | 19,05 | 20 | 20 | 20 | 25 | | | | | |
| | Ø | 20 | 22 | 22 | 22 | 25,40 | | | | | |
| | Ø | 22 | 25 | 25 | 25 | | | | | | |
| | Ø | | 25,40 | 25,40 | 25,40 | | | | | | |
| CODOLO CONO MORSE "CM" "CM" MORSE TAPER CONNECTION | | | | | | 2 | 3 | 3-4 | 3-4 | 3-4 | 4-5 |
| A RICHIESTA / ON DEMAND: CODOLO "ISO - DIN 69871 / DIN 2080" "ISO-DIN 69871 / DIN 2080" CONNECTION | | | | | | | 30-40 | 40 | 40-50 | 40-50 | 40-50 |
| CODOLO "VDI" "VDI" CONNECTION | | | | | | | | VDI 30 | VDI 30 | VDI 40 | VDI 40 |
| | | | | | | | | VDI 30 | VDI 40 | VDI 40 | |
| CODOLO "CAPTO ISO-26623" "CAPTO ISO-26623" CONNECTION | | | | | | | 3 | 4-5 | 4-5 | 4-5 | |



A richiesta / On demand:
CODOLO "HSK"
"HSK" CONNECTION

Brocciatori REGISTRABILI > vedi pag.12
Adjustable Broaching Head > see page 12





Brocciatori con passaggio refrigerante interno serie "BRC"

- Caratteristiche tecniche e dimensioni

Broaching Heads series "BRC" with internal coolant passage
- Technical characteristics and dimensions



| CARATTERISTICHE / FEATURES | dim. | BROCCIATORE "BRC" / "BRC" BROACHING HEAD | | | | | | | |
|---|------|---|--------|----------|----------|---------|----------|----------|-------|
| | | BRC-G8 | | | BRC-G12 | | BRC-G16 | | |
| | | BRC-G8M | BRC-G8 | BRC-G8HP | BRC-G12B | BRC-G12 | BRC-G16M | BRC-G16L | |
| GAMBO DELLA BROCCIA SHANK OF THE BROACH | d | mm | Ø8 | Ø8 | Ø8 | Ø12 | Ø12 | Ø16 | Ø16 |
| CAPACITA' CAVE ESAGONALI HEXAGONAL SLOT CAPACITY | | mm | 3÷8 | 3÷10 | 3÷10 | 3÷12 | 3÷15 | 5÷30 | 8÷30 |
| CAPACITA' CAVE QUADRE SQUARE SLOT CAPACITY | | mm | 3÷6 | 3÷8 | 3÷8 | 3÷10 | 3÷12 | 6÷20 | 10÷25 |
| CAPACITA' CAVE TORX® TORX® SLOT CAPACITY | T | | 8÷30 | 8÷40 | 8÷40 | 8÷40 | 8÷60 | 20÷70 | 30÷70 |
| CAPACITA' CAVE TORX® PLUS TORX® PLUS SLOT CAPACITY | IP | | 8÷30 | 8÷40 | 8÷40 | 8÷40 | 8÷60 | 20÷70 | 30÷70 |
| PROFONDITA' MAX DI LAVORO MAXIMUM WORKING DEPTH | mm | Vedi dettaglio nelle singole tabelle delle brocche See details in the individual broaches tables | | | | | | | |
| DIMENSIONE CORPO BODY DIMENSIONS | H | mm | 47,5 | 55 | 55 | 66,5 | 81,5 | 91 | 99 |
| DIMENSIONE CORPO BODY DIMENSIONS | K | mm | Ø29,5 | Ø37 | Ø37 | Ø47 | Ø58 | Ø68 | Ø79 |
| PESO (indicativo) WEIGHT (indicative) | gr. | | 338 | 525 | 535 | 851 | 1653 | 1830 | 3500 |

NOVITA'
NEW

a richiesta
on demand

NOVITA'
NEW

| TIPO DI ATTACCO / CONNECTIONS | BROCCIATORE "BRC" / "BRC" BROACHING HEAD | | | | | | | |
|---|--|--------|----------|----------|---------|----------|----------|----|
| | BRC-G8 | | | BRC-G12 | | BRC-G16 | | |
| | BRC-G8M | BRC-G8 | BRC-G8HP | BRC-G12B | BRC-G12 | BRC-G16M | BRC-G16L | |
| CODOLO CILINDRICO CYLINDRICAL CONNECTION | Ø | 10 | 10 | 10 | 16 | 20 | 25 | 25 |
| | Ø | 12 | 12 | 12 | 19,05 | 25 | 32 | 32 |
| | Ø | 16 | 16 | 16 | 20 | 32 | 40 | 40 |
| | Ø | 19,05 | 19,05 | 19,05 | 22 | | | |
| | Ø | 20 | 20 | 20 | 25 | | | |
| | Ø | 22 | 22 | 22 | 25,40 | | | |
| | Ø | 25 | 25 | 25 | | | | |
| | Ø | 25,40 | 25,40 | 25,40 | | | | |

passaggio refrigerante **interno**
Internal coolant passage

CON IL CODOLO CILINDRICO, PER POTER AVERE IL PASSAGGIO REFRIGERANTE INTERNO, E' NECESSARIO MONTARE BROCCHE SERIE "BRC" > vedi da pag. 14

WITH THE CYLINDRICAL SHANK, IN ORDER TO HAVE THE COOLANT PASSAGE IT IS NECESSARY TO USE "BRC" SERIES BROACHES > see page 14



| | | | | | | | |
|----------------------------------|--|--|--|--|--------|--------|--------|
| CODOLO "VDI" "VDI" CONNECTION | | | | | | VDI 30 | VDI 40 |
| | | | | | VDI 30 | VDI 40 | |

passaggio refrigerante **esterno**
External coolant passage

CON IL CODOLO VDI POSSONO ESSERE UTILIZZATE ANCHE LE BROCCHE STANDARD (NON "BRC")
STANDARD BROACHES (NON "BRC") CAN ALSO BE USED WITH THE VDI SHANK





Brocciatori Registrabili serie "BR"

- Caratteristiche tecniche e dimensioni

Adjustable Broaching Head "BR" series

- Technical characteristics and dimensions



I Nel sistema di brocciature in cave interne e per profili esterni, il **brocciatore Registrabile** rappresenta una novità rispetto ai modelli tradizionali attualmente presenti sul mercato mondiale e può essere utilizzato, come qualsiasi altro brocciatore BR, su macchine utensili tradizionali e CNC. La caratteristica principale del brocciatore registrabile consiste nella **possibilità di utilizzare brocche di qualsiasi lunghezza compresa tra 18 e 30 mm (per versione BR-G8A) e tra 25 e 60 mm (per versione BR-G12A)**. Questo significa che la profondità max. di lavoro (L vedi fig.2) può arrivare ad un massimo di 60 mm, mentre la profondità utile di brocciatura (L1 vedi fig.2) può arrivare fino a 20 mm.

L'operazione di sostituzione della broccia, per ottenere brocciature in diverse profondità, avviene in modo semplice e rapido: agendo sulla vite di registro e con l'ausilio del calibro di azzeramento, in dotazione al brocciatore, si regola il brocciatore stesso in funzione della lunghezza della broccia. Allo stesso modo si deve procedere nel caso di brocciatura per profili esterni.

Per un utilizzo ottimale del brocciatore è opportuno ricordare che, a parità di materiale e sezione della broccia, all'aumentare della lunghezza della broccia aumenta il "carico di punta". Per questo motivo è necessario ridurre la velocità di avanzamento e il numero di giri.

GB Among traditional broaching devices for inside holes and surface profiles present in the world market at the time being, the **Adjustable broaching head** is a great novelty. Like all the others BR broaching heads, it can be installed on both traditional and CNC machine tools.

The main feature of the adjustable broaching head is its **suitability for every kind of broach with a length between 18 and 30 mm (for version BR-G8A) and between 25 and 60 mm (for version BR-G12A)**. This means that the maximum broaching depth achievable by this holder is 60 mm (L in picture 2), while the maximum depth of the shape is 20 mm (L1 in picture 2).

The adjustable broaching head must be adjusted every time a broach with a different length is used. This operation is easy and fast: using a special gauging tool, supplied together with the holder, it is possible to regulate the setting screw on the basis of the broach length. The same process is valid for surface broaches.

To use correctly a broaching head is very important to always keep in mind that, even if the material to machine and the requested shape are the same, the more a broach is long the greater the effort of the machining at the end of the broach is. For this reason it is a good habit of reducing feed and speed if long broaches are used.

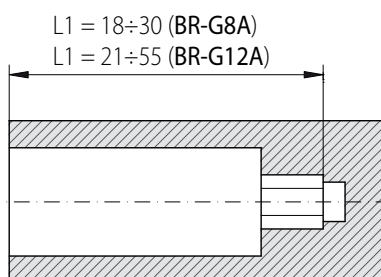

Fig 2



**NOVITA'
NEW**



BR-G8A



BR-G12A

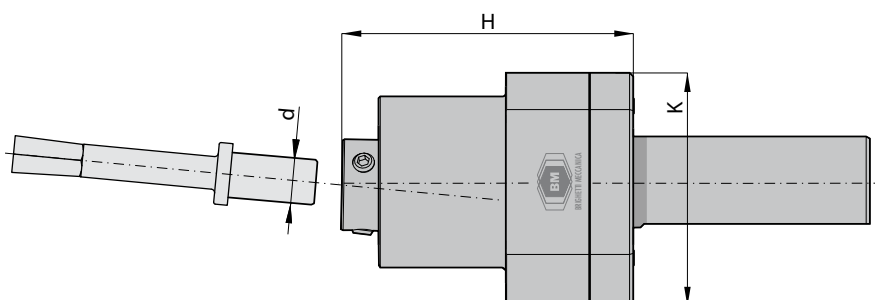

| CARATTERISTICHE / FEATURES | dim. | BROCCIATORE BROACHING HEAD (BR) | | |
|---|------|------------------------------------|---------|---------|
| | | BR-G8A | BR-G12A | |
| GAMBO DELLA BROCCIA SHANK OF THE BROACH | d | mm | Ø8 | Ø12 |
| CAPACITA' CAVE ESAGONALI HEXAGONAL SLOT CAPACITY | | mm | 1÷10 | 4÷15 |
| CAPACITA' CAVE QUADRE SQUARE SLOT CAPACITY | | mm | 1÷8 | 4÷12 |
| CAPACITA' CAVE TORX® TORX® SLOT CAPACITY | | T | 3÷40 * | 3÷60 ** |
| CAPACITA' CAVE TORX® PLUS TORX® PLUS SLOT CAPACITY | | IP | 6÷40 * | 6÷60 ** |
| PROFONDITA' MAX DI LAVORO MAXIMUM WORKING DEPTH | | mm | 18÷30 | 21÷55 |
| DIMENSIONE CORPO BODY DIMENSIONS | H | mm | 56 | 80 |
| DIMENSIONE CORPO BODY DIMENSIONS | K | mm | 45 | 64 |
| PESO (indicativo) WEIGHT (indicative) | | gr. | 700 | 1625 |

| TIPO DI ATTACCO / CONNECTIONS | BROCCIATORE / BROACHING HEAD (BR) | | |
|--|--------------------------------------|--------|--------------------------|
| | | BR-G8A | BR-G12A |
| CODOLO CILINDRICO CYLINDRICAL CONNECTION | Ø | 16 | 19,05 |
| | Ø | 19,05 | 20 |
| | Ø | 20 | 22 |
| | Ø | 22 | 25 |
| | Ø | 25 | 25,40 |
| | Ø | 25,40 | 32 |
| CODOLO CONO MORSE "CM" "CM" MORSE TAPER CONNECTION | | | 3 |
| A RICHIESTA / ON DEMAND: CODOLO "ISO - DIN 69871 / DIN 2080" "ISO-DIN 69871 / DIN 2080" CONNECTION | | | 30 - 40 |
| CODOLO "VDI" "VDI" CONNECTION | | | VDI 30 |
| | | | VDI 40 |
| CODOLO "CAPTO ISO-26623" "CAPTO ISO-26623" CONNECTION | | | a richiesta on demand |



Sul brocciatore **BR-G8A**

montare le brocche:

- metriche **G8A** > vedi pag. 22

- in pollici **GP8A** > vedi pag. 38

Broaching head BR-G8A can be used:

- metric broaches **G8A** > see page 22

- inches broaches **GP8A** > see page 38



Sul brocciatore **BR-G12A**

montare le brocche:

- metriche **G12A** > vedi pag. 25

- in pollici **GP12A** > vedi pag. 40

Broaching head BR-G12A can be used:

- metric broaches **G12A** > see page 25

- inches broaches **GP12A** > see page 40

* Brocche standard: L = 18.

A richiesta possiamo fornire brocche con L maggiore di 18

** Standard broaches: L = 18.

Broaches with L greater than 18 can be supplied upon request.

** Brocche standard: L = 25.

A richiesta possiamo fornire brocche con L maggiore di 25

** Standard broaches: L = 25.

Broaches with L greater than 25 can be supplied upon request.



Brocche per cave poligonali su Brocciatori serie "BR" e "BRC" Broaches for polygonal holes on broaching heads "BR" and "BRC" series



I La BROCCIA per cave poligonali è un utensile opportunamente sagomato; da un lato viene fissata al mandrino del Brocciatore e dall'altra riporta il profilo della cava da eseguire. Le brocche di questa famiglia di prodotti sono realizzate in due tipi di acciaio:

- acciaio HSS. Si tratta di un tipo di acciaio che si distingue per l'elevata resistenza alla usura e per l'alta capacità di assorbimento delle vibrazioni che si sprigionano durante la fase di brocciatura
- acciaio SINTERIZZATO. Si distingue per l'eccellente durezza e resistenza alla compressione e in ambiente ad alte temperature. Il suo impiego è particolarmente indicato nelle lavorazioni molto gravose e in presenza di metalli molto resistenti (es: acciaio inox, titanio).

Le brocche sono costruite in sette serie di grandezze, contraddistinte dal diametro del gambo di accoppiamento con il brocciatore: G5, G8, G8A, G12, G12A, G16, G16L, G25, ecc. Oltre agli articoli standard presentati nel Catalogo Generale, la BRIGHETTI MECCANICA s.r.l. è in grado di costruire profili particolari, sulla base delle specifiche tecniche richieste dal Cliente.

Importante

Prima di eseguire la brocciatura è necessario praticare al pezzo un preforo leggermente maggiorato (vedere pagina 15) rispetto al diametro della broccia e più profondo (in base alla tenacità del materiale può variare dal 20% al 40% in più) in fori ciechi per consentire lo sfogo del truciolo. Per operazioni di brocciatura piuttosto gravose si consiglia l'utilizzo di un opportuno olio da taglio durante la lavorazione.

GB The BROACH for polygonal holes is a specially shaped tool that is fixed to the spindle of the broaching head on one end, while the other end bears the shape of the hole to be obtained. These broaches are made in two different kind of steels:

- HSS This steel has a good resistance to wear and tear and a high capacity to absorb the vibrations of the broaching machining
- SINTERED steel. This steel has a high hardness and an excellent resistance to compression, even at high temperatures. It is used for heavy machinings when hard materials are involved (i.e. stainless steels, titanium)

BRIGHETTI MECCANICA S.r.l. produces seven kinds of broaches with different shanks fitting perfectly the broach seat: G5, G8, G8A, G12, G12A, G16, G16L, G25, etc.. Beside standard items mentioned in the General Catalogue, BRIGHETTI MECCANICA SRL can produce broaches with special profile and sizes, following Customer's specification.

Important

Before starting with the broaching operation, a pre-broach hole must be drilled on the work piece. This pre-broach hole should be a little bit larger (see page 15) than the size of the broach and a little bit deeper (the pre-broach hole should be from +20% to +40% considering the hardness of the material to machine) in order to discharge the chips. It is a good habit of using a good cutting oil during the broaching operation.



Pre-foro per brocciatura profili esagonali, quadri, Torx® e Torx® Plus

Pre-hole broaching: exagonal, square, Torx® and Torx® Plus

I Prima della procedura di brocciatura è fondamentale generare uno smusso in testa al pre foro. La profondità del pre-foro si incrementa del 20%-40% rispetto al profilo utile da eseguire. La soluzione ottimale, comunque, sarebbe quella di eseguire una gola di scarico alla fine del foro, per agevolare ulteriormente lo scarico del truciolo.

GB Before the broaching procedure it is essential to create a chamfer on the pre-hole. The depth of the pre-hole is increased by: 20% -40% compared to the profile to be obtained; the best solution, however, it's to get a chip discharge groove, at the end of the profile, to facilitate the chip evacuation.



BROCCHE ESAGONALI / EXAGONAL BROACHES

| dimens. | PRE FORO PRE-HOLE | dimens. | PRE FORO PRE-HOLE |
|---------|----------------------|---------|----------------------|
| 1 | ø1,05 +0,10/0 | 18 | ø18,55 +0,20/0 |
| 1,2 | ø1,25 +0,10/0 | 19 | ø19,55 +0,20/0 |
| 1,5 | ø1,55 +0,10/0 | 20 | ø20,60 +0,20/0 |
| 2 | ø2,10 +0,10/0 | 22 | ø22,65 +0,20/0 |
| 2,5 | ø2,60 +0,10/0 | 24 | ø24,70 +0,20/0 |
| 3 | ø3,10 +0,10/0 | 25 | ø25,75 +0,30/0 |
| 3,5 | ø3,60 +0,10/0 | 26 | ø26,80 +0,30/0 |
| 4 | ø4,15 +0,10/0 | 27 | ø27,80 +0,30/0 |
| 5 | ø5,15 +0,10/0 | 28 | ø28,85 +0,30/0 |
| 6 | ø6,20 +0,10/0 | 29 | ø29,90 +0,30/0 |
| 7 | ø7,20 +0,15/0 | 30 | ø30,90 +0,30/0 |
| 8 | ø8,25 +0,15/0 | 31 | ø32,00 +0,30/0 |
| 9 | ø9,25 +0,15/0 | 32 | ø33,20 +0,30/0 |
| 10 | ø10,30 +0,15/0 | 33 | ø34,30 +0,30/0 |
| 11 | ø11,30 +0,15/0 | 34 | ø35,35 +0,30/0 |
| 12 | ø12,35 +0,15/0 | 35 | ø36,40 +0,40/0 |
| 13 | ø13,40 +0,15/0 | 36 | ø37,45 +0,40/0 |
| 14 | ø14,40 +0,15/0 | 37 | ø38,50 +0,40/0 |
| 15 | ø15,45 +0,20/0 | 38 | ø39,50 +0,40/0 |
| 16 | ø16,45 +0,20/0 | 39 | ø40,65 +0,45/0 |
| 17 | ø17,50 +0,20/0 | 40 | ø42,00 +0,45/0 |



BROCCHE ESAGONALI IN POLLICI / EXAGONAL INCHES BROACHES

| dimens. | PRE FORO PRE-HOLE | dimens. | PRE FORO PRE-HOLE |
|---------|----------------------|---------|----------------------|
| 3/32" | ø2,45 +0,10/0 | 5/16" | ø8,15 +0,15/0 |
| 1/8" | ø3,25 +0,10/0 | 3/8" | ø9,80 +0,15/0 |
| 5/32" | ø4,10 +0,10/0 | 1/2" | ø13,10 +0,15/0 |
| 3/16" | ø4,90 +0,10/0 | 9/16" | ø14,70 +0,15/0 |
| 7/32" | ø5,70 +0,10/0 | 5/8" | ø16,35 +0,20/0 |
| 1/4" | ø6,55 +0,10/0 | 3/4" | ø19,60 +0,20/0 |
| 9/32" | ø7,35 +0,15/0 | 7/8" | ø22,90 +0,20/0 |



BROCCHE TORX / TORX BROACHES

| dimens. | PRE FORO PRE-HOLE | dimens. | PRE FORO PRE-HOLE |
|---------|----------------------|---------|----------------------|
| T3 | ø0,95 +0,05/0 | T25 | ø3,40 +0,10/0 |
| T4 | ø1,05 +0,05/0 | T27 | ø3,80 +0,10/0 |
| T5 | ø1,20 +0,05/0 | T30 | ø4,15 +0,10/0 |
| T6 | ø1,40 +0,10/0 | T40 | ø5,00 +0,15/0 |
| T7 | ø1,60 +0,10/0 | T45 | ø5,80 +0,15/0 |
| T8 | ø1,90 +0,10/0 | T50 | ø6,70 +0,20/0 |
| T9 | ø1,95 +0,10/0 | T55 | ø8,20 +0,20/0 |
| T10 | ø2,20 +0,10/0 | T60 | ø9,85 +0,20/0 |
| T15 | ø2,60 +0,10/0 | T70 | ø11,45 +0,20/0 |
| T20 | ø3,00 +0,10/0 | | |

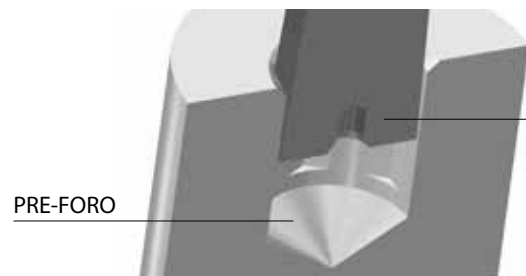

PRE-FORO

BROCCIA



BROCCHE QUADRE / SQUARE BROACHES

| dimens. | PRE FORO PRE-HOLE | dimens. | PRE FORO PRE-HOLE |
|---------|----------------------|---------|----------------------|
| 1 | ø1,15 +0,10/0 | 12 | ø13,20 +0,20/0 |
| 1,5 | ø1,65 +0,10/0 | 13 | ø14,70 +0,20/0 |
| 2 | ø2,20 +0,10/0 | 14 | ø15,80 +0,20/0 |
| 2,5 | ø2,75 +0,10/0 | 15 | ø16,95 +0,25/0 |
| 3 | ø3,30 +0,10/0 | 16 | ø18,10 +0,25/0 |
| 3,5 | ø3,85 +0,10/0 | 17 | ø19,20 +0,25/0 |
| 4 | ø4,40 +0,10/0 | 18 | ø20,90 +0,25/0 |
| 5 | ø5,50 +0,15/0 | 19 | ø22,05 +0,25/0 |
| 6 | ø6,60 +0,15/0 | 20 | ø23,20 +0,30/0 |
| 7 | ø7,70 +0,15/0 | 21 | ø24,35 +0,30/0 |
| 8 | ø8,80 +0,15/0 | 22 | ø25,50 +0,30/0 |
| 9 | ø9,90 +0,15/0 | 23 | ø26,70 +0,30/0 |
| 10 | ø11,00 +0,20/0 | 24 | ø27,85 +0,30/0 |
| 11 | ø12,10 +0,20/0 | 25 | ø29,00 +0,30/0 |



BROCCHE QUADRE IN POLLICI / SQUARE INCHES BROACHES

| dimens. | PRE FORO PRE-HOLE | dimens. | PRE FORO PRE-HOLE |
|---------|----------------------|---------|----------------------|
| 3/32" | ø2,60 +0,10/0 | 5/16" | ø8,75 +0,15/0 |
| 1/8" | ø3,50 +0,10/0 | 3/8" | ø10,50 +0,20/0 |
| 5/32" | ø4,35 +0,10/0 | 1/2" | ø14,35 +0,20/0 |
| 3/16" | ø5,25 +0,15/0 | 9/16" | ø16,15 +0,25/0 |
| 7/32" | ø6,10 +0,15/0 | 5/8" | ø17,95 +0,25/0 |
| 1/4" | ø7,00 +0,15/0 | 3/4" | ø21,55 +0,35/0 |
| 9/32" | ø7,70 +0,15/0 | 7/8" | ø25,10 +0,35/0 |



BROCCHE TORX PLUS / TORX PLUS BROACHES

| dimens. | PRE FORO PRE-HOLE | dimens. | PRE FORO PRE-HOLE |
|---------|----------------------|---------|----------------------|
| IP6 | ø1,45 +0,10/0 | IP30 | ø4,60 +0,10/0 |
| IP8 | ø1,95 +0,10/0 | IP40 | ø5,50 +0,10/0 |
| IP9 | ø2,10 +0,10/0 | IP45 | ø6,55 +0,10/0 |
| IP10 | ø2,30 +0,10/0 | IP50 | ø7,25 +0,15/0 |
| IP15 | ø2,75 +0,10/0 | IP55 | ø9,45 +0,15/0 |
| IP20 | ø3,25 +0,10/0 | IP60 | ø10,95 +0,20/0 |
| IP25 | ø3,65 +0,10/0 | IP70 | ø12,95 +0,20/0 |
| IP27 | ø4,15 +0,10/0 | | |



Smussi per brocciatura profili esagonali, quadri, Torx®

Chamfer broaching: exagonal, square, Torx®

I Per effettuare una corretta brocciatura, è necessario realizzare uno smusso in testa al pre-foro. Questo smusso, ha la funzione di accompagnare la broccia verso il pre-foro evitando che si scheggi prima che essa cominci il lavoro di compressione del materiale. E' fondamentale appoggiare la broccia allo smusso a macchina ferma.

GB To carry out correct broaching, it is necessary to create a chamfer at the head of the pre-hole. This chamfer has the function of accompanying the broach towards the pre-hole, preventing it from chipping before it begins the work of compressing the material. It is essential to rest the broach on the chamfer with the machine stopped.



ESAGONI METRICI / METRIC HEXAGONS

| dimens. | DIAMETRO SMUSSO CHAMFER DIAMETER | dimens. | DIAMETRO SMUSSO CHAMFER DIAMETER |
|---------|-------------------------------------|---------|-------------------------------------|
| 2 | 2,4 | 21 | 24,5 |
| 2,5 | 3 | 22 | 25,6 |
| 3 | 3,6 | 23 | 26,8 |
| 3,5 | 4,15 | 24 | 28 |
| 4 | 4,75 | 25 | 29,1 |
| 5 | 5,9 | 26 | 30,25 |
| 6 | 7,05 | 27 | 31,45 |
| 7 | 8,2 | 28 | 32,6 |
| 8 | 9,35 | 29 | 33,75 |
| 9 | 10,5 | 30 | 34,9 |
| 10 | 11,67 | 31 | 36,1 |
| 11 | 12,85 | 32 | 37,2 |
| 12 | 14 | 33 | 38,4 |
| 13 | 15,15 | 34 | 39,55 |
| 14 | 16,3 | 35 | 40,7 |
| 15 | 17,5 | 36 | 41,9 |
| 13 | 15,15 | 37 | 42,95 |
| 14 | 16,3 | 38 | 44,1 |
| 15 | 17,5 | 39 | 45,26 |
| 16 | 18,65 | 40 | 46,45 |
| 17 | 19,8 | 41 | 47,6 |
| 18 | 21 | 42 | 48,9 |
| 19 | 22,15 | 44 | 51,1 |
| 20 | 23,3 | 46 | 53,4 |



QUADRI METRICI / METRIC SQUARE

| dimens. | DIAMETRO SMUSSO CHAMFER DIAMETER | dimens. | DIAMETRO SMUSSO CHAMFER DIAMETER |
|---------|-------------------------------------|---------|-------------------------------------|
| 3 | 4,35 | 16 | 22,8 |
| 4 | 5,8 | 17 | 24,2 |
| 5 | 7,2 | 18 | 25,65 |
| 6 | 8,6 | 19 | 27,05 |
| 7 | 10 | 20 | 28,5 |
| 8 | 11,45 | 21 | 29,9 |
| 9 | 12,85 | 22 | 31,35 |
| 10 | 14,3 | 23 | 32,75 |
| 11 | 15,7 | 24 | 34,15 |
| 12 | 17,1 | 25 | 35,6 |
| 13 | 18,55 | 26 | 36,9 |
| 14 | 19,95 | 27 | 38,4 |
| 15 | 21,35 | 28 | 39,75 |



QUADRI IN POLLICI / SQUARE IN INCHES

| dimens. | DIAMETRO SMUSSO CHAMFER DIAMETER | dimens. | DIAMETRO SMUSSO CHAMFER DIAMETER |
|---------|-------------------------------------|---------|-------------------------------------|
| 1/4" | 9,9 | 3/4" | 27,15 |
| 3/8" | 13,6 | 1" | 36,1 |
| 1/2" | 18,1 | | |



ESAGONI IN POLLICI / HEXAGONS IN INCHES

| dimens. | DIAMETRO SMUSSO CHAMFER DIAMETER | dimens. | DIAMETRO SMUSSO CHAMFER DIAMETER |
|---------|-------------------------------------|---------|-------------------------------------|
| 1/8" | 3,75 | 7/16" | 12,95 |
| 5/32" | 4,7 | 1/2" | 14,85 |
| 3/16" | 5,6 | 9/16" | 16,7 |
| 7/32" | 6,55 | 5/8" | 18,5 |
| 1/4" | 7,45 | 3/4" | 22,2 |
| 5/16" | 9,3 | 7/8" | 25,9 |
| 3/8" | 11,15 | 1" | 29,55 |



TORX / TORX

| dimens. | DIAMETRO SMUSSO CHAMFER DIAMETER | dimens. | DIAMETRO SMUSSO CHAMFER DIAMETER |
|---------|-------------------------------------|---------|-------------------------------------|
| 6 | 1,8 | 27 | 5,15 |
| 7 | 2,1 | 30 | 5,65 |
| 8 | 2,45 | 40 | 6,85 |
| 9 | 2,6 | 45 | 8 |
| 10 | 2,85 | 50 | 9 |
| 15 | 3,4 | 55 | 11,4 |
| 20 | 4 | 60 | 13,5 |
| 25 | 4,6 | 70 | 15,8 |



Parametri di utilizzo per lavorazioni con brocche in HSS e Sinterizzato

Working parameters for broach machining made of HSS and sintered material

| BROCCE IN ACCIAIO HSS HSS STEEL BROACHES | | MATERIALE DA LAVORARE / MATERIAL TO WORK | | | | | | | | | | | | | | | | | | | |
|--|----------------------------------|--|------------------------------------|---------------------------------------|--|---------------------------------------|---------------------------------------|------------------------------------|------------------------------------|------------------------------------|------------------------------------|-------|----------|------|-----------|-------|----------|------|-----------|-------------|-----------|
| | | ALLUMINIO ALUMINUM | ACCIAIO STEEL | ACCIAIO STEEL | ACCIAIO STEEL | ACCIAIO INOX STAINLESS STEEL | ACCIAIO INOX STAINLESS STEEL | GHISA CAST IRON | TITANIO TITANIUM | RAME COPPER | OTTONE BRASS | | | | | | | | | | |
| PARAMETRI DI UTILIZZO WORK PARAMETERS | | Vc m/min=55 | Vc m/min=40 | Vc m/min=38 | Vc m/min=30 | Vc m/min=25 | Vc m/min=20 | Vc m/min=30 | | | | | | | | | | | | Vc m/min=40 | |
| ROTAZIONE MANDRINO: M4 SPINDLE ROTATION: M4 | | Rm <500 (N/mm ²) | Rm <700 (N/mm ²) | Rm 700-850 (N/mm ²) | Rm 850-1050 (N/mm ²) | Rm <900 (N/mm ²) | Rm 1050 (N/mm ²) | Rm <600 (N/mm ²) | Rm >700 (N/mm ²) | Rm <350 (N/mm ²) | Rm <350 (N/mm ²) | | | | | | | | | | |
| PROFILO PROFILE | dimensioni dimensions (mm) | LUBRIFICAZIONE NECESSARIA / LUBRICATION REQUIRED | | | | | | | | | | | | | | | | | | | |
| | | f | S | f | S | f | S | f | S | f | S | f | S | f | S | f | S | f | S | f | S |
| ESAGONALE HEXAGONAL | 1 - 12,9 | 0,12 | 1000/2000 | 0,10 | 1000/1800 | 0,08 | 1100/1600 | 0,05 | 800/1400 | 0,08 | 1100/1600 | 0,04 | 900/1200 | 0,10 | 1200/1800 | 0,03 | 900/1200 | 0,12 | 1200/1900 | 0,10 | 1200/1800 |
| | 13 - 23,9 | 0,08 | 1000 | 0,08 | 900 | 0,06 | 700 | 0,02 | 650 | 0,06 | 850 | 0,03 | 700 | 0,06 | 850 | 0,02 | 650 | 0,09 | 900 | 0,07 | 900 |
| | 24 - 40 | 0,05 | 700 | 0,05 | 650 | 0,04 | 600 | 0,01 | 500 | 0,04 | 600 | 0,02 | 500 | 0,03 | 650 | 0,01 | 450 | 0,05 | 700 | 0,04 | 600 |
| QUADRATO SQUARE | 1 - 10,9 | 0,10 | 1000/2000 | 0,06 | 1300/1800 | 0,05 | 1100/1600 | 0,02 | 800/1400 | 0,05 | 1100/1600 | 0,03 | 900/1200 | 0,08 | 1200/1800 | 0,02 | 900/1200 | 0,10 | 1200/1900 | 0,08 | 1200/1800 |
| | 11 - 20,9 | 0,06 | 1000 | 0,04 | 900 | 0,03 | 700 | 0,02 | 650 | 0,04 | 850 | 0,02 | 700 | 0,05 | 850 | 0,02 | 650/900 | 0,08 | 900 | 0,06 | 900 |
| | 21 - 25 | 0,03 | 700 | 0,02 | 650 | 0,02 | 600 | 0,01 | 500 | 0,02 | 600 | 0,01 | 500 | 0,03 | 650 | 0,01 | 450 | 0,06 | 700 | 0,04 | 600 |
| TORX® (T) TORX®PLUS (IP) | T3 - T6 | 0,14 | 1000/2000 | 0,10 | 1300/1800 | 0,08 | 1100/1600 | 0,05 | 800/1400 | 0,08 | 1100/1600 | 0,045 | 900/1200 | 0,10 | 1200/1800 | 0,035 | 900/1200 | 0,12 | 1200/1900 | 0,10 | 1200/1800 |
| | T7 - T27 IP6 - IP27 | 0,12 | 1000 | 0,09 | 900 | 0,07 | 700 | 0,04 | 650 | 0,07 | 850 | 0,04 | 700 | 0,09 | 850 | 0,03 | 650 | 0,11 | 900 | 0,09 | 900 |
| | T30 - T70 IP30 - IP70 | 0,10 | 700 | 0,07 | 650 | 0,05 | 600 | 0,03 | 500 | 0,06 | 600 | 0,03 | 500 | 0,06 | 650 | 0,02 | 450 | 0,09 | 700 | 0,07 | 600 |

Legenda / Legend:

f = avanzamento (mm/giro) / advancement (millimeters/round)

S = velocità (giri/min) / RPM (rounds/minute)

Vc = velocità di taglio (m/min) / cutting speed (millimeters/minute)

| BROCCE IN ACCIAIO SINTERIZZATO SINTERED STEEL BROACHES | | MATERIALE DA LAVORARE / MATERIAL TO WORK | | | | | | | | | | | | | | | | | | | |
|--|----------------------------------|--|------------------------------------|---------------------------------------|--|---------------------------------------|---------------------------------------|------------------------------------|------------------------------------|------------------------------------|------------------------------------|-------|----------|------|-----------|-------|----------|------|-----------|------|-----------|
| | | ALLUMINIO ALUMINUM | ACCIAIO STEEL | ACCIAIO STEEL | ACCIAIO STEEL | ACCIAIO INOX STAINLESS STEEL | ACCIAIO INOX STAINLESS STEEL | GHISA CAST IRON | TITANIO TITANIUM | RAME COPPER | OTTONE BRASS | | | | | | | | | | |
| PARAMETRI DI UTILIZZO WORK PARAMETERS | | Rm <500 (N/mm ²) | Rm <700 (N/mm ²) | Rm 700-850 (N/mm ²) | Rm 850-1050 (N/mm ²) | Rm <900 (N/mm ²) | Rm 1050 (N/mm ²) | Rm <600 (N/mm ²) | Rm >700 (N/mm ²) | Rm <350 (N/mm ²) | Rm <350 (N/mm ²) | | | | | | | | | | |
| ROTAZIONE MANDRINO: M4 SPINDLE ROTATION: M4 | | | | | | | | | | | | | | | | | | | | | |
| PROFILO PROFILE | dimensioni dimensions (mm) | LUBRIFICAZIONE NECESSARIA / LUBRICATION REQUIRED | | | | | | | | | | | | | | | | | | | |
| | | f | S | f | S | f | S | f | S | f | S | f | S | f | S | f | S | f | S | f | S |
| ESAGONALE HEXAGONAL | 1 - 12,9 | 0,14 | 1000/2000 | 0,12 | 1000/1800 | 0,10 | 1000/1600 | 0,07 | 900/1400 | 0,09 | 950/1600 | 0,055 | 850/1200 | 0,12 | 1300/1800 | 0,05 | 800/1000 | 0,16 | 1200/1900 | 0,12 | 1300/1800 |
| | 13 - 23,9 | 0,11 | 1000 | 0,10 | 950 | 0,08 | 750 | 0,04 | 750 | 0,07 | 800 | 0,045 | 750 | 0,08 | 950 | 0,04 | 600 | 0,12 | 950 | 0,09 | 800 |
| | 24 - 40 | 0,08 | 850 | 0,07 | 850 | 0,05 | 650 | 0,015 | 600 | 0,05 | 750 | 0,025 | 650 | 0,05 | 850 | 0,02 | 500 | 0,08 | 850 | 0,06 | 700 |
| QUADRATO SQUARE | 1 - 10,9 | 0,11 | 1000 | 0,08 | 1400/1800 | 0,07 | 1000/1600 | 0,05 | 900/1400 | 0,07 | 950/1600 | 0,045 | 850/1200 | 0,10 | 1300/1800 | 0,04 | 800/1000 | 0,12 | 1200/1900 | 0,09 | 1300/1800 |
| | 11 - 20,9 | 0,08 | 1000 | 0,06 | 950 | 0,06 | 750 | 0,04 | 750 | 0,06 | 800 | 0,035 | 750 | 0,07 | 950 | 0,04 | 600 | 0,10 | 950/1200 | 0,07 | 800 |
| | 21 - 40 | 0,06 | 850 | 0,04 | 850 | 0,04 | 650 | 0,02 | 600 | 0,04 | 750 | 0,015 | 650 | 0,04 | 850 | 0,02 | 500 | 0,07 | 850 | 0,04 | 700 |
| TORX® (T) TORX®PLUS (IP) | T3 - T6 | 0,16 | 1500 | 0,12 | 1400/1800 | 0,10 | 1000/1600 | 0,07 | 900/1400 | 0,09 | 950/1600 | 0,06 | 850/1200 | 0,12 | 1300/1800 | 0,05 | 800/1000 | 0,16 | 1200/1900 | 0,13 | 1300/1800 |
| | T7 - T27 IP6 - IP27 | 0,13 | 1000 | 0,11 | 950/1400 | 0,09 | 750 | 0,06 | 750 | 0,08 | 800 | 0,045 | 750 | 0,10 | 950 | 0,045 | 600 | 0,15 | 950 | 0,11 | 800 |
| | T30 - T70 IP30 - IP70 | 0,11 | 850 | 0,10 | 850/950 | 0,08 | 650 | 0,05 | 600 | 0,07 | 750 | 0,04 | 650 | 0,09 | 850 | 0,04 | 500 | 0,12 | 850 | 0,09 | 700 |



Rivestimenti per brocche

Coatings for broaches



I A seconda della tipologia di materiale da lavorare, sulle brocche possono essere applicati rivestimenti per migliorarne la durata in termini di numero di pezzi prodotti, come **HDP RED (STAR 4)**, **WONDER/TIALN**, **TiN**, **INOX PLUS** e **ZIRINOS**.

Di seguito alcuni esempi di materiali da lavorare con i grafici che ne evidenziano la differenza fra l'utensile realizzato in HSS o SINTERIZZATO normale rispetto all'utensile rivestito.

GB Depending on the type of material to be machined, coatings can be applied to the broaches to improve their durability in terms of number of work-pieces produced, such as **HDP RED (STAR 4)**, **WONDER/TIALN**, **TiN**, **INOX PLUS** and **ZIRINOS**.

Here are some examples of materials to be machined with the graphs highlighting the difference between the tool made of normal HSS or SINTERED and the coated tool.

| Materiale broccia Broach material | Materiale da lavorare Machined material | Rivestimenti / Coatings | | | | |
|--------------------------------------|---|-------------------------|-----|------------------|-----------|---------|
| | | HDP RED | TiN | WONDER/ TIALN | INOX PLUS | ZIRINOS |
| HSS | ALLUMINIO / ALUMINIUM - RM <500 N/mm ² | ✓ | | | | |
| HSS | ACCIAI / STEEL - RM 700 ÷ 850 N/mm ² | | ✓ | | | |
| HSS | ACCIAI / STEEL - RM 1250 ÷ 1400 N/mm ² | | | ✓ | | |
| HSS | ACCIAIO INOX / STAINLESS STEEL - RM ≤ 900 N/mm ² | | | ✓ | ✓ | |
| HSS | ACCIAIO INOX / STAINLESS STEEL - RM ≥ 900 N/mm ² | | | | ✓ | |
| SINTERIZZATO | TITANIO - TITANIUM - RM > 700 N/mm ² | | | | | ✓ |

materiale da lavorare/machined material: **ALLUMINIO/ALUMINIUM 6082**
rivestimento applicato/applied coating: **HDP RED (STAR 4)**

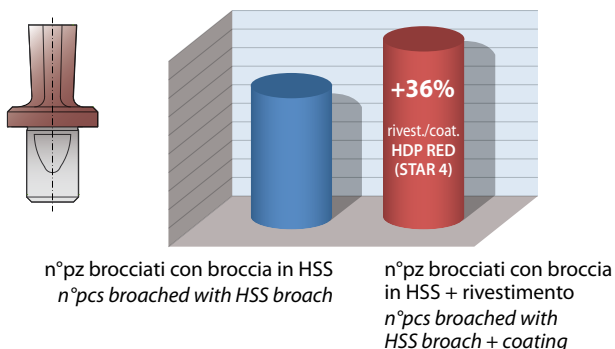

materiale da lavorare/machined material: **ACCIAIO16NiCr4/16NiCr4 STEEL**
rivestimento applicato/applied coating: **WONDER / TIALN**

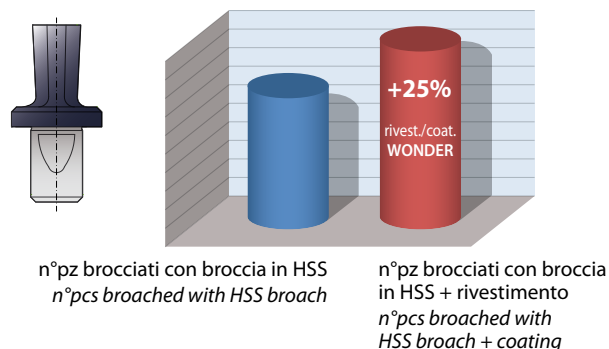

materiale da lavorare/machined material: **ACCIAIO C40/C40 STEEL**
rivestimento applicato/applied coating: **TiN**

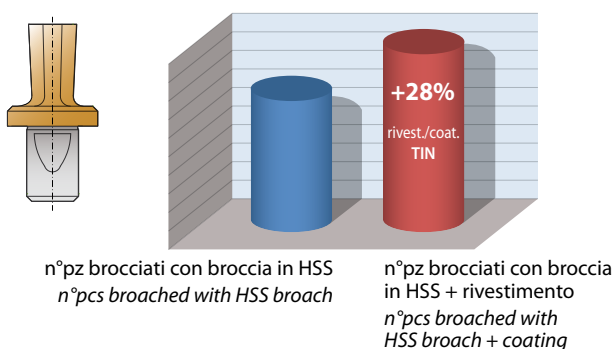

materiale da lavorare/machined material: **INOX 304/304 STAINLESS STEEL**
rivestimento applicato/applied coating: **INOX PLUS**

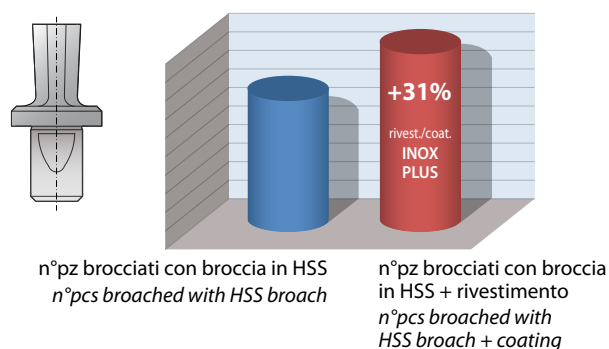

materiale da lavorare/machined material: **TITANIO/TITANIUM**
rivestimento applicato/applied coating: **ZIRINOS**

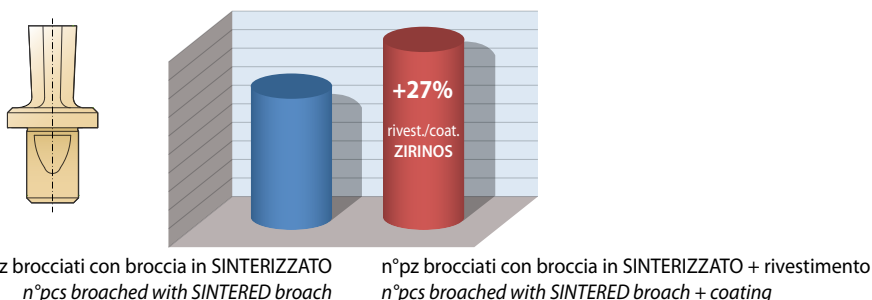



BROCCHE G5 - DIAMETRO "d" DEL GAMBO: 5 mm

G5 BROACHES - 5 mm SHANK DIAMETER ("d")

Sezione ESAGONALE standard (E)

Standard HEXAGONAL section (E)

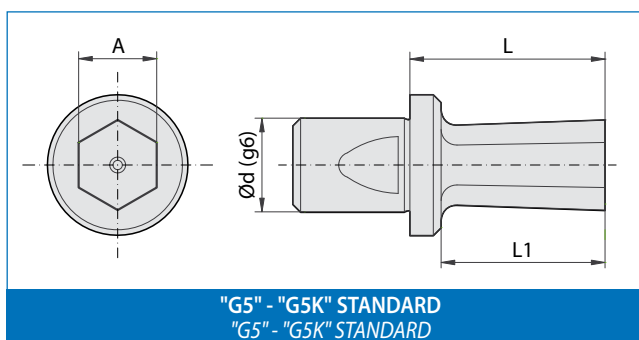

"G5" - "G5K" STANDARD
"G5" - "G5K" STANDARD

| ARTICOLO (materiale) ITEM (material) | | DIMENSIONI - DIMENSIONS | | | | Utilizzo su Brocciatori/ Use on Broaching heads |
|---|--------------------------|-------------------------|-----------------|-----|----|--|
| HSS | SINTERIZZATO SINTERED | d | A | L1 | L | |
| Standard | Standard | | | | | Standard BR-G5 |
| G5-E-1 | G5K-E-1 | 5 | 1 +0,04 +0,06 | 2 | 10 | |
| G5-E-1,5 | G5K-E-1,5 | 5 | 1,5 +0,05 +0,07 | 3 | 10 | |
| G5-E-2 | G5K-E-2 | 5 | 2 +0,05 +0,07 | 4 | 10 | |
| G5-E-2,5 | G5K-E-2,5 | 5 | 2,5 +0,05 +0,07 | 5 | 10 | |
| G5-E-3 | G5K-E-3 | 5 | 3 +0,06 +0,08 | 6 | 10 | |
| G5-E-3,5 | G5K-E-3,5 | 5 | 3,5 +0,06 +0,08 | 6 | 10 | |
| G5-E-4 | G5K-E-4 | 5 | 4 +0,07 +0,09 | 7 | 10 | |
| G5-E-4,5 | G5K-E-4,5 | 5 | 4,5 +0,07 +0,09 | 7 | 10 | |
| G5-E-5 | G5K-E-5 | 5 | 5 +0,08 +0,10 | 7,5 | 10 | |
| G5-E-5,5 | G5K-E-5,5 | 5 | 5,5 +0,08 +0,10 | 7,5 | 10 | |
| G5-E-6 | G5K-E-6 | 5 | 6 +0,08 +0,10 | 7,5 | 10 | |

Sezione QUADRA standard (Q)

Standard SQUARE section (Q)

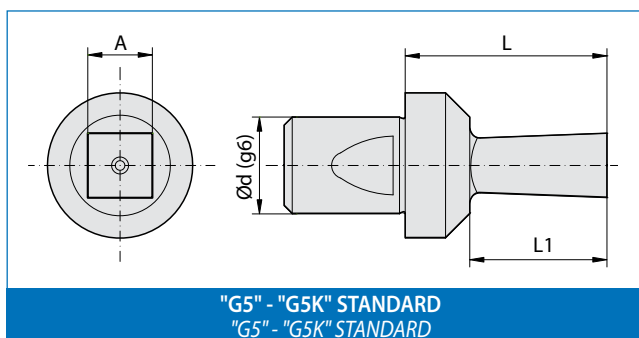

"G5" - "G5K" STANDARD
"G5" - "G5K" STANDARD

| ARTICOLO (materiale) ITEM (material) | | DIMENSIONI - DIMENSIONS | | | | Utilizzo su Brocciatori/ Use on Broaching heads |
|---|--------------------------|-------------------------|-----------------|----|----|--|
| HSS | SINTERIZZATO SINTERED | d | A | L1 | L | |
| Standard | Standard | | | | | Standard BR-G5 |
| G5-Q-1 | G5K-Q-1 | 5 | 1 +0,04 +0,06 | 2 | 10 | |
| G5-Q-1,5 | G5K-Q-1,5 | 5 | 1,5 +0,05 +0,07 | 3 | 10 | |
| G5-Q-2 | G5K-Q-2 | 5 | 2 +0,05 +0,07 | 4 | 10 | |
| G5-Q-2,5 | G5K-Q-2,5 | 5 | 2,5 +0,06 +0,08 | 5 | 10 | |
| G5-Q-3 | G5K-Q-3 | 5 | 3 +0,06 +0,08 | 6 | 10 | |
| G5-Q-3,5 | G5K-Q-3,5 | 5 | 3,5 +0,07 +0,09 | 6 | 10 | |
| G5-Q-4 | G5K-Q-4 | 5 | 4 +0,07 +0,09 | 7 | 10 | |

In questi articoli possiamo eseguire i seguenti rivestimenti: **HDP RED, WONDER, TiN, INOX PLUS e ZIRINOS** > vedi pag.18
Available coatings for the up above mentioned items: **HDP RED, WONDER, TiN, INOX PLUS and ZIRINOS** > see page 18





BROCCE G8 E G8C - DIAMETRO "d" DEL GAMBO: 8 mm
G8 AND G8C BROACHES - 8 mm SHANK DIAMETER ("d")

Sezione ESAGONALE (E)
HEXAGONAL section (E)

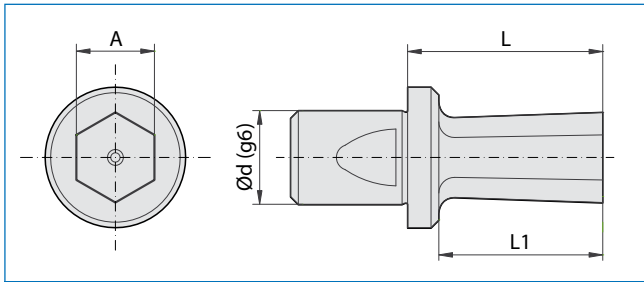

"G8" - "G8K" STANDARD
 "G8" - "G8K" STANDARD

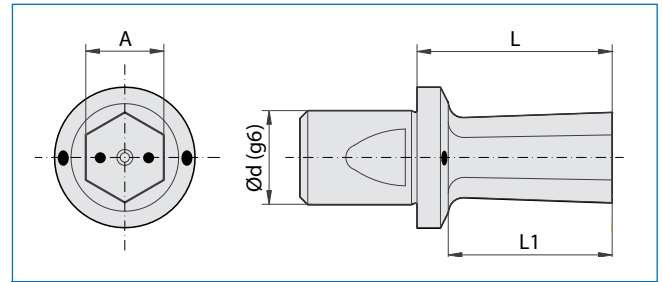

"G8C" - "G8KC" CON PASSAGGIO REFRIGERANTE INTERNO
 "G8C" - "G8KC" WITH INTERNAL FLOW OF COOLANT

| ARTICOLO (materiale) - ITEM (material) | | | | DIMENSIONI - DIMENSIONS | | | | Utilizzo su Brocciatori/ Use on Broaching heads | |
|--|--------------|-------------------------|--------------|-------------------------|-----------------|----|----|--|--|
| HSS | | SINTERIZZATO / SINTERED | | d | A | L1 | L | | |
| Standard | Ref. / Cool. | Standard | Ref. / Cool. | | | | | | |
| G8-E-1 | / | G8K-E-1 | / | 8 | 1 +0,04 +0,06 | 2 | 18 | Standard BR-G8S BR-G8M BR-G8 BR-G8A | |
| G8-E-1,5 | | G8K-E-1,5 | | 8 | 1,5 +0,05 +0,07 | 3 | 18 | | |
| G8-E-2 | | G8K-E-2 | | 8 | 2 +0,05 +0,07 | 5 | 18 | | |
| G8-E-2,5 | | G8K-E-2,5 | | 8 | 2,5 +0,05 +0,07 | 6 | 18 | | |
| G8-E-3 | G8C-E-3 | G8K-E-3 | G8KC-E-3 | 8 | 3 +0,06 +0,08 | 7 | 18 | | Refrig. / Cool. BRC-G8M BRC-G8 BRC-G8HP |
| G8-E-3,5 | G8C-E-3,5 | G8K-E-3,5 | G8KC-E-3,5 | 8 | 3,5 +0,06 +0,08 | 8 | 18 | | |
| G8-E-4 | G8C-E-4 | G8K-E-4 | G8KC-E-4 | 8 | 4 +0,07 +0,09 | 9 | 18 | | |
| G8-E-4,5 | G8C-E-4,5 | G8K-E-4,5 | G8KC-E-4,5 | 8 | 4,5 +0,07 +0,09 | 9 | 18 | | |
| G8-E-5 | G8C-E-5 | G8K-E-5 | G8KC-E-5 | 8 | 5 +0,08 +0,10 | 11 | 18 | | |
| G8-E-5,5 | G8C-E-5,5 | G8K-E-5,5 | G8KC-E-5,5 | 8 | 5,5 +0,08 +0,10 | 11 | 18 | | |
| G8-E-6 | G8C-E-6 | G8K-E-6 | G8KC-E-6 | 8 | 6 +0,08 +0,10 | 13 | 18 | | |
| G8-E-7 | G8C-E-7 | G8K-E-7 | G8KC-E-7 | 8 | 7 +0,08 +0,10 | 13 | 18 | | |
| G8-E-8 | G8C-E-8 | G8K-E-8 | G8KC-E-8 | 8 | 8 +0,08 +0,10 | 13 | 18 | | |
| G8-E-9 | G8C-E-9 | G8K-E-9 | G8KC-E-9 | 8 | 9 +0,09 +0,11 | 13 | 18 | | |
| G8-E-10 | G8C-E-10 | G8K-E-10 | G8KC-E-10 | 8 | 10 +0,10 +0,12 | 13 | 18 | | |

In questi articoli possiamo eseguire i seguenti rivestimenti: **HDP RED, WONDER, TiN, INOX PLUS e ZIRINOS** > vedi pag.18
 Available coatings for the up above mentioned items: **HDP RED, WONDER, TiN, INOX PLUS and ZIRINOS** > see page 18





BROCCHE G8 E G8C - DIAMETRO "d" DEL GAMBO: 8 mm

G8 AND G8C BROACHES - 8 mm SHANK DIAMETER ("d")

Sezione QUADRA (Q)

SQUARE section (Q)

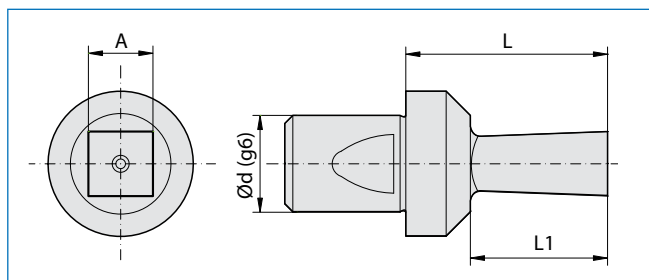

"G8" - "G8K" STANDARD
"G8" - "G8K" STANDARD

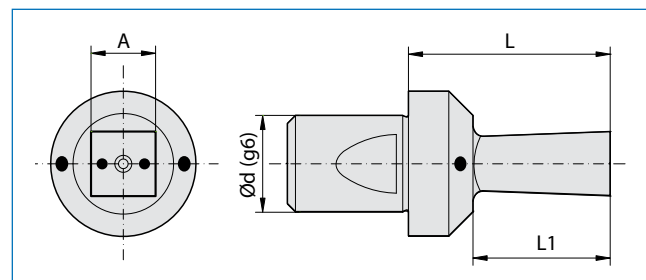

"G8C" - "G8KC" CON PASSAGGIO REFRIGERANTE INTERNO
"G8C" - "G8KC" WITH INTERNAL FLOW OF COOLANT

| ARTICOLO (materiale) - ITEM (material) | | | | DIMENSIONI - DIMENSIONS | | | | Utilizzo su Brocciatori/ Use on Broaching heads |
|--|---------------------------------------|-----------------------------------|---------------------------------------|-------------------------|-----------------|----|----|--|
| HSS | | SINTERIZZATO / SINTERED | | d | A | L1 | L | |
| Standard <input type="checkbox"/> | Ref. / Cool. <input type="checkbox"/> | Standard <input type="checkbox"/> | Ref. / Cool. <input type="checkbox"/> | | | | | |
| G8-Q-1 | / | G8K-Q-1 | / | 8 | 1 +0,04 +0,06 | 2 | 18 | Standard BR-G8S BR-G8M BR-G8 BR-G8A |
| G8-Q-1,5 | | G8K-Q-1,5 | | 8 | 1,5 +0,05 +0,07 | 3 | 18 | |
| G8-Q-2 | | G8K-Q-2 | | 8 | 2 +0,05 +0,07 | 5 | 18 | |
| G8-Q-2,5 | | G8K-Q-2,5 | | 8 | 2,5 +0,06 +0,08 | 6 | 18 | |
| G8-Q-3 | G8C-Q-3 | G8K-Q-3 | G8KC-Q-3 | 8 | 3 +0,06 +0,08 | 7 | 18 | Refrig. / Cool. BRC-G8M BRC-G8 BRC-G8HP |
| G8-Q-3,5 | G8C-Q-3,5 | G8K-Q-3,5 | G8KC-Q-3,5 | 8 | 3,5 +0,06 +0,08 | 8 | 18 | |
| G8-Q-4 | G8C-Q-4 | G8K-Q-4 | G8KC-Q-4 | 8 | 4 +0,07 +0,09 | 9 | 18 | |
| G8-Q-4,5 | G8C-Q-4,5 | G8K-Q-4,5 | G8KC-Q-4,5 | 8 | 4,5 +0,07 +0,09 | 9 | 18 | |
| G8-Q-5 | G8C-Q-5 | G8K-Q-5 | G8KC-Q-5 | 8 | 5 +0,08 +0,10 | 11 | 18 | |
| G8-Q-5,5 | G8C-Q-5,5 | G8K-Q-5,5 | G8KC-Q-5,5 | 8 | 5,5 +0,08 +0,10 | 11 | 18 | |
| G8-Q-6 | G8C-Q-6 | G8K-Q-6 | G8KC-Q-6 | 8 | 6 +0,08 +0,10 | 13 | 18 | |
| G8-Q-7 | G8C-Q-7 | G8K-Q-7 | G8KC-Q-7 | 8 | 7 +0,08 +0,10 | 13 | 18 | |
| G8-Q-8 | G8C-Q-8 | G8K-Q-8 | G8KC-Q-8 | 8 | 8 +0,08 +0,10 | 13 | 18 | |

In questi articoli possiamo eseguire i seguenti rivestimenti: **HDP RED, WONDER, TiN, INOX PLUS e ZIRINOS** > vedi pag.18
Available coatings for the up above mentioned items: **HDP RED, WONDER, TiN, INOX PLUS and ZIRINOS** > see page 18





BROCCE G8A - DIAMETRO "d" DEL GAMBO: 8 mm
G8A BROACHES - 8 mm SHANK DIAMETER ("d")

NOVITA' NEW

Per Brocciatori REGISTRABILI /
For ADJUSTABLE Broaching Heads
BR-G8A



Sezione ESAGONALE standard (E)
Standard HEXAGONAL section (E)

Sezione QUADRA standard (Q)
Standard SQUARE section (Q)

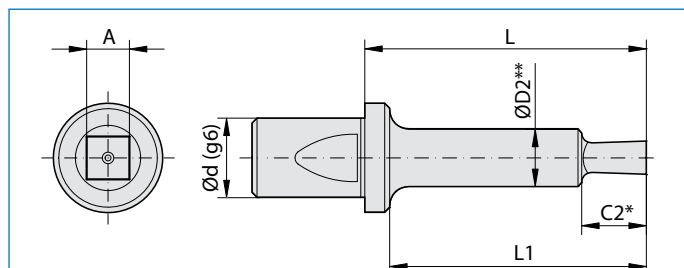
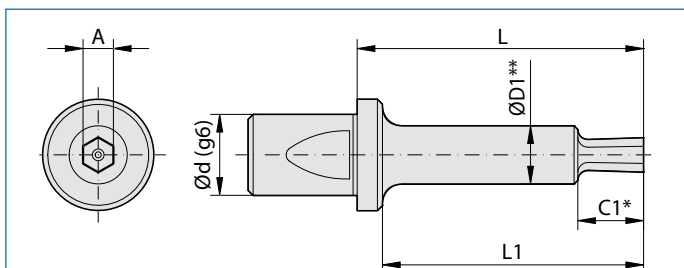

"G8A" - "G8AK" STANDARD
 "G8A" - "G8AK" STANDARD

"G8A" - "G8AK" STANDARD
 "G8A" - "G8AK" STANDARD

| ESAGONALE / HEXAGONAL | |
|---|--------------------------|
| ARTICOLO (materiale) ITEM (material) | |
| HSS | SINTERIZZATO SINTERED |
| Standard | Standard |
| G8A-E-3 | G8AK-E-3 |
| G8A-E-3,5 | G8AK-E-3,5 |
| G8A-E-4 | G8AK-E-4 |
| G8A-E-4,5 | G8AK-E-4,5 |
| G8A-E-5 | G8AK-E-5 |
| G8A-E-5,5 | G8AK-E-5,5 |
| G8A-E-6 | G8AK-E-6 |
| G8A-E-7 | G8AK-E-7 |

| QUADRA / SQUARE | |
|---|--------------------------|
| ARTICOLO (materiale) ITEM (material) | |
| HSS | SINTERIZZATO SINTERED |
| Standard | Standard |
| G8A-Q-3 | G8AK-Q-3 |
| G8A-Q-3,5 | G8AK-Q-3,5 |
| G8A-Q-4 | G8AK-Q-4 |
| G8A-Q-4,5 | G8AK-Q-4,5 |
| G8A-Q-5 | G8AK-Q-5 |
| G8A-Q-5,5 | G8AK-Q-5,5 |
| G8A-Q-6 | G8AK-Q-6 |
| G8A-Q-7 | G8AK-Q-7 |

| DIMENSIONI - DIMENSIONS | | | | | | | | Utilizzo su Brocciatori/ Use on Broaching heads |
|-------------------------|-----------------|----|----|------|------|------|------|--|
| d | A | L1 | L | C1* | C2* | D1** | D2** | |
| 8 | 3 +0,06 +0,08 | 26 | 30 | 8,5 | 8,5 | 6,5 | 6,5 | Standard BR-G8A |
| 8 | 3,5 +0,06 +0,08 | 26 | 30 | 11,5 | 11,5 | 6,5 | 7,5 | |
| 8 | 4 +0,07 +0,09 | 26 | 30 | 11,5 | 11,5 | 6,5 | 7,5 | |
| 8 | 4,5 +0,07 +0,09 | 26 | 30 | 13 | 13 | 7,5 | 8,5 | |
| 8 | 5 +0,08 +0,10 | 26 | 30 | 13 | 13 | 7,5 | 8,5 | |
| 8 | 5,5 +0,08 +0,10 | 26 | 30 | 15 | 15 | 8,5 | 9,5 | |
| 8 | 6 +0,08 +0,10 | 26 | 30 | 15 | 15 | 8,5 | 9,5 | |
| 8 | 7 +0,08 +0,10 | 26 | 30 | 16,5 | 16,5 | 9,5 | 10,5 | |

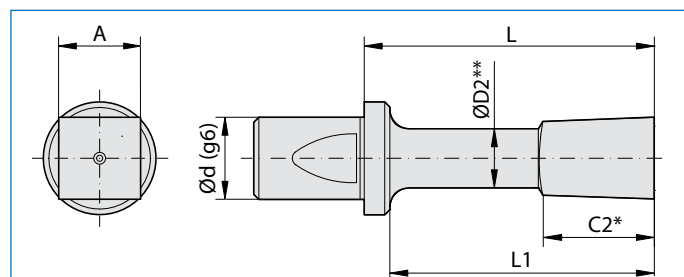
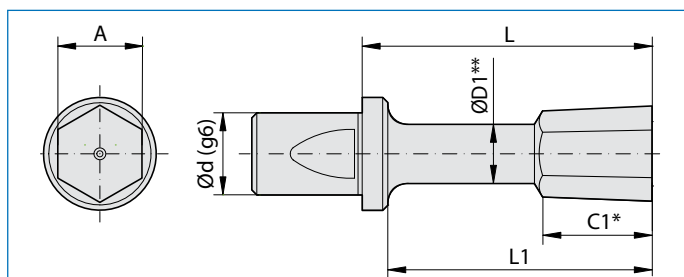

"G8A" - "G8AK" STANDARD
 "G8A" - "G8AK" STANDARD

"G8A" - "G8AK" STANDARD
 "G8A" - "G8AK" STANDARD

| | |
|----------|-----------|
| G8A-E-8 | G8AK-E-8 |
| G8A-E-9 | G8AK-E-9 |
| G8A-E-10 | G8AK-E-10 |

| | |
|---------|----------|
| G8A-Q-8 | G8AK-Q-8 |
| / | / |

| | | | | | | | | |
|---|----------------|----|----|----|----|---|---|--------------------|
| 8 | 8 +0,08 +0,10 | 26 | 30 | 11 | 11 | 6 | 6 | Standard BR-G8A |
| 8 | 9 +0,09 +0,11 | 26 | 30 | 11 | / | 7 | / | |
| 8 | 10 +0,10 +0,12 | 26 | 30 | 11 | / | 8 | / | |

C = Profondità utile di brocciatura / C = Depth of the shape
 L1 = Profondità max. di lavoro / L1 = Maximum broaching depth

* le quote C1 e C2 possono essere maggiori rispetto alla tabella. In tal caso contattare la Brighetti Meccanica.
 the dimensions C1 and C2 may be greater than in the table. In this case, contact Brighetti Meccanica.

** le quote D1 e D2 possono essere modificate a seconda della profondità di lavoro da realizzare. In tal caso contattare la Brighetti Meccanica.
 the dimensions D1 and D2 can be modified depending on the working depth to be achieved. In this case, contact Brighetti Meccanica.

In questi articoli possiamo eseguire i seguenti rivestimenti: **HDP RED, WONDER, TiN, INOX PLUS e ZIRINOS** > vedi pag.18
 Available coatings for the up above mentioned items: **HDP RED, WONDER, TiN, INOX PLUS and ZIRINOS** > see page 18





BROCCHE G12 E G12C - DIAMETRO "d" DEL GAMBO: 12 mm

G12 AND G12C BROACHES - 12 mm SHANK DIAMETER ("d")

Sezione ESAGONALE (E)

HEXAGONAL section (E)

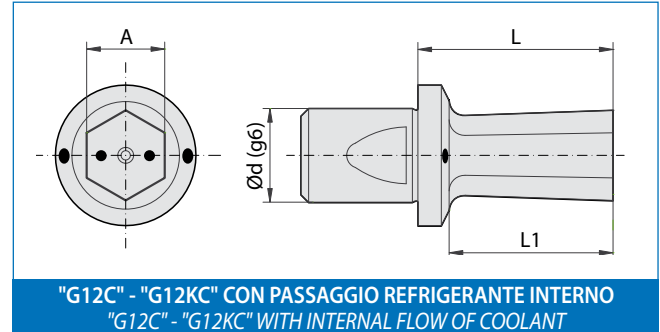
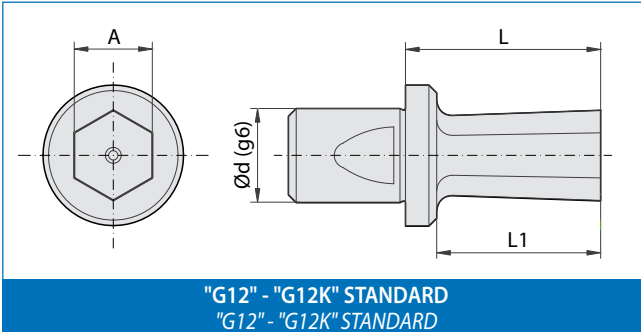

| ARTICOLO (materiale) - ITEM (material) | | | | DIMENSIONI - DIMENSIONS | | | | Utilizzo su Brocciatori/ Use on Broaching heads | |
|--|--------------|-------------------------|--------------|-------------------------|-----------------|----|----|--|--|
| HSS | | SINTERIZZATO / SINTERED | | d | A | L1 | L | | |
| Standard | Ref. / Cool. | Standard | Ref. / Cool. | | | | | | |
| G12-E-1 | / | G12K-E-1 | / | 12 | 1 +0,04 +0,06 | 2 | 25 | Standard BR-G12B BR-G12 BR-G12A | |
| G12-E-1,5 | | G12K-E-1,5 | | 12 | 1,5 +0,05 +0,07 | 3 | 25 | | |
| G12-E-2 | | G12K-E-2 | | 12 | 2 +0,05 +0,07 | 5 | 25 | | |
| G12-E-2,5 | | G12K-E-2,5 | | 12 | 2,5 +0,05 +0,07 | 6 | 25 | | |
| G12-E-3 | G12C-E-3 | G12K-E-3 | G12KC-E-3 | 12 | 3 +0,06 +0,08 | 7 | 25 | | |
| G12-E-3,5 | G12C-E-3,5 | G12K-E-3,5 | G12KC-E-3,5 | 12 | 3,5 +0,06 +0,08 | 8 | 25 | | |
| G12-E-4 | G12C-E-4 | G12K-E-4 | G12KC-E-4 | 12 | 4 +0,07 +0,09 | 9 | 25 | | |
| G12-E-4,5 | G12C-E-4,5 | G12K-E-4,5 | G12KC-E-4,5 | 12 | 4,5 +0,07 +0,09 | 9 | 25 | | |
| G12-E-5 | G12C-E-5 | G12K-E-5 | G12KC-E-5 | 12 | 5 +0,08 +0,10 | 11 | 25 | | |
| G12-E-5,5 | G12C-E-5,5 | G12K-E-5,5 | G12KC-E-5,5 | 12 | 5,5 +0,08 +0,10 | 11 | 25 | | |
| G12-E-6 | G12C-E-6 | G12K-E-6 | G12KC-E-6 | 12 | 6 +0,08 +0,10 | 13 | 25 | | |
| G12-E-7 | G12C-E-7 | G12K-E-7 | G12KC-E-7 | 12 | 7 +0,08 +0,10 | 15 | 25 | | Refrig. / Cool. BRC-G12B BRC-G12 |
| G12-E-8 | G12C-E-8 | G12K-E-8 | G12KC-E-8 | 12 | 8 +0,08 +0,10 | 17 | 25 | | |
| G12-E-9 | G12C-E-9 | G12K-E-9 | G12KC-E-9 | 12 | 9 +0,09 +0,11 | 19 | 25 | | |
| G12-E-10 | G12C-E-10 | G12K-E-10 | G12KC-E-10 | 12 | 10 +0,10 +0,12 | 21 | 25 | | |
| G12-E-11 | G12C-E-11 | G12K-E-11 | G12KC-E-11 | 12 | 11 +0,10 +0,12 | 21 | 25 | | |
| G12-E-12 | G12C-E-12 | G12K-E-12 | G12KC-E-12 | 12 | 12 +0,11 +0,13 | 21 | 25 | | |
| G12-E-13 | G12C-E-13 | G12K-E-13 | G12KC-E-13 | 12 | 13 +0,11 +0,13 | 21 | 25 | | |
| G12-E-14 | G12C-E-14 | G12K-E-14 | G12KC-E-14 | 12 | 14 +0,12 +0,14 | 21 | 25 | | |
| G12-E-15 | G12C-E-15 | G12K-E-15 | G12KC-E-15 | 12 | 15 +0,13 +0,15 | 21 | 25 | | |

In questi articoli possiamo eseguire i seguenti rivestimenti: HDP RED, WONDER, TiN, INOX PLUS e ZIRINOS > vedi pag.18
Available coatings for the up above mentioned items: HDP RED, WONDER, TiN, INOX PLUS and ZIRINOS > see page 18





BROCCE G12 E G12C - DIAMETRO "d" DEL GAMBO: 12 mm

G12 AND G12C BROACHES - 12 mm SHANK DIAMETER ("d")

Sezione QUADRA (Q)

SQUARE section (Q)

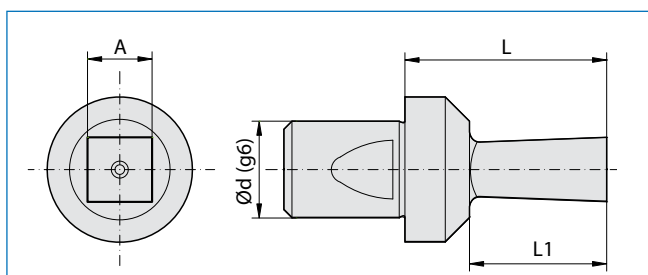

"G12" - "G12K" STANDARD
"G12" - "G12K" STANDARD

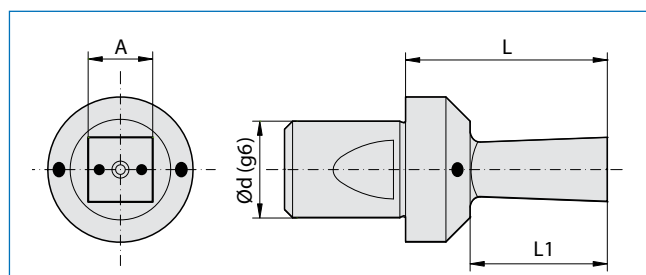

"G12C" - "G12KC" CON PASSAGGIO REFRIGERANTE INTERNO
"G12C" - "G12KC" WITH INTERNAL FLOW OF COOLANT

| ARTICOLO (materiale) - ITEM (material) | | | | DIMENSIONI - DIMENSIONS | | | | Utilizzo su Broccatori/ Use on Broaching heads | |
|--|---------------------------------------|-----------------------------------|---------------------------------------|-------------------------|-----------------|----|----|---|--|
| HSS | | SINTERIZZATO / SINTERED | | d | A | L1 | L | | |
| Standard <input type="checkbox"/> | Ref. / Cool. <input type="checkbox"/> | Standard <input type="checkbox"/> | Ref. / Cool. <input type="checkbox"/> | | | | | | |
| G12-Q-1 | / | G12K-Q-1 | / | 12 | 1 +0,04 +0,06 | 2 | 25 | Standard BR-G12B BR-G12 BR-G12A | |
| G12-Q-1,5 | | G12K-Q-1,5 | | 12 | 1,5 +0,05 +0,07 | 3 | 25 | | |
| G12-Q-2 | | G12K-Q-2 | | 12 | 2 +0,05 +0,07 | 5 | 25 | | |
| G12-Q-2,5 | | G12K-Q-2,5 | | 12 | 2,5 +0,05 +0,07 | 6 | 25 | | |
| G12-Q-3 | G12C-Q-3 | G12K-Q-3 | G12KC-Q-3 | 12 | 3 +0,06 +0,08 | 7 | 25 | | Refrig. / Cool. BRC-G12B BRC-G12 |
| G12-Q-3,5 | G12C-Q-3,5 | G12K-Q-3,5 | G12KC-Q-3,5 | 12 | 3,5 +0,06 +0,08 | 8 | 25 | | |
| G12-Q-4 | G12C-Q-4 | G12K-Q-4 | G12KC-Q-4 | 12 | 4 +0,07 +0,09 | 9 | 25 | | |
| G12-Q-4,5 | G12C-Q-4,5 | G12K-Q-4,5 | G12KC-Q-4,5 | 12 | 4,5 +0,07 +0,09 | 9 | 25 | | |
| G12-Q-5 | G12C-Q-5 | G12K-Q-5 | G12KC-Q-5 | 12 | 5 +0,08 +0,10 | 11 | 25 | | |
| G12-Q-5,5 | G12C-Q-5,5 | G12K-Q-5,5 | G12KC-Q-5,5 | 12 | 5,5 +0,08 +0,10 | 11 | 25 | | |
| G12-Q-6 | G12C-Q-6 | G12K-Q-6 | G12KC-Q-6 | 12 | 6 +0,08 +0,10 | 13 | 25 | | |
| G12-Q-7 | G12C-Q-7 | G12K-Q-7 | G12KC-Q-7 | 12 | 7 +0,08 +0,10 | 15 | 25 | | |
| G12-Q-8 | G12C-Q-8 | G12K-Q-8 | G12KC-Q-8 | 12 | 8 +0,08 +0,10 | 17 | 25 | | |
| G12-Q-9 | G12C-Q-9 | G12K-Q-9 | G12KC-Q-9 | 12 | 9 +0,09 +0,11 | 19 | 25 | | |
| G12-Q-10 | G12C-Q-10 | G12K-Q-10 | G12KC-Q-10 | 12 | 10 +0,10 +0,12 | 21 | 25 | | |
| G12-Q-11 | G12C-Q-11 | G12K-Q-11 | G12KC-Q-11 | 12 | 11 +0,10 +0,12 | 21 | 25 | | |
| G12-Q-12 | G12C-Q-12 | G12K-Q-12 | G12KC-Q-12 | 12 | 12 +0,11 +0,13 | 21 | 25 | | |

In questi articoli possiamo eseguire i seguenti rivestimenti: HDP RED, WONDER, TiN, INOX PLUS e ZIRINOS > vedi pag.18
Available coatings for the up above mentioned items: HDP RED, WONDER, TiN, INOX PLUS and ZIRINOS > see page 18





**Per Brocciatori REGISTRABILI /
For ADJUSTABLE Broaching Heads
BR-G12A**



**BROCCE G12A - DIAMETRO "d" DEL GAMBO: 12 mm
G12A BROACHES - 12 mm SHANK DIAMETER ("d")**

**Sezione ESAGONALE standard (E)
Standard HEXAGONAL section (E)**

**Sezione QUADRA standard (Q)
Standard SQUARE section (Q)**

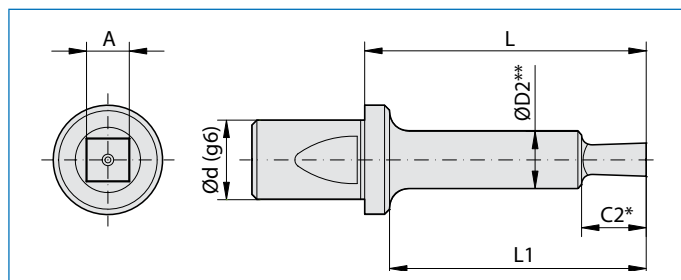
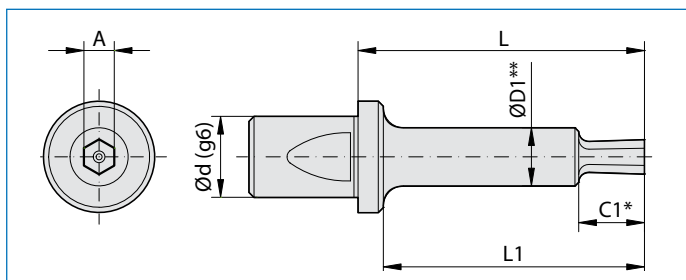

"G12A" - "G12AK" STANDARD
"G12A" - "G12AK" STANDARD

"G12A" - "G12AK" STANDARD
"G12A" - "G12AK" STANDARD

| ESAGONALE / HEXAGONAL | |
|---|--------------------------|
| ARTICOLO (materiale) ITEM (material) | |
| HSS | SINTERIZZATO SINTERED |
| Standard | Standard |
| G12A-E-4 | G12AK-E-4 |
| G12A-E-4,5 | G12AK-E-4,5 |
| G12A-E-5 | G12AK-E-5 |
| G12A-E-5,5 | G12AK-E-5,5 |
| G12A-E-6 | G12AK-E-6 |

| QUADRA / SQUARE | |
|---|--------------------------|
| ARTICOLO (materiale) ITEM (material) | |
| HSS | SINTERIZZATO SINTERED |
| Standard | Standard |
| G12A-Q-4 | G12AK-Q-4 |
| G12A-Q-4,5 | G12AK-Q-4,5 |
| G12A-Q-5 | G12AK-Q-5 |
| / | / |

| DIMENSIONI - DIMENSIONS | | | | | | | | | Utilizzo su Brocciatori/ Use on Broaching heads |
|-------------------------|-----------------|----|----|-----|-----|------|------|---------------------|--|
| d | A | L1 | L | C1* | C2* | D1** | D2** | | |
| 12 | 4 +0,07 +0,09 | 55 | 60 | 9 | 9 | 10 | 10 | Standard BR-G12A | |
| 12 | 4,5 +0,07 +0,09 | 55 | 60 | 11 | 11 | 10 | 10 | | |
| 12 | 5 +0,08 +0,10 | 55 | 60 | 11 | 11 | 10 | 10 | | |
| 12 | 5,5 +0,08 +0,10 | 55 | 60 | 11 | / | 10 | / | | |
| 12 | 6 +0,08 +0,10 | 55 | 60 | 13 | / | 10 | / | | |
| 12 | 6 +0,08 +0,10 | 55 | 60 | 13 | / | 10 | / | | |

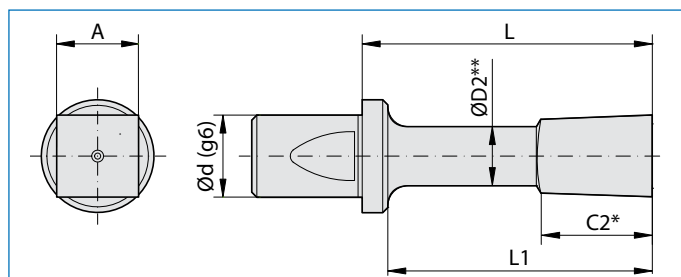
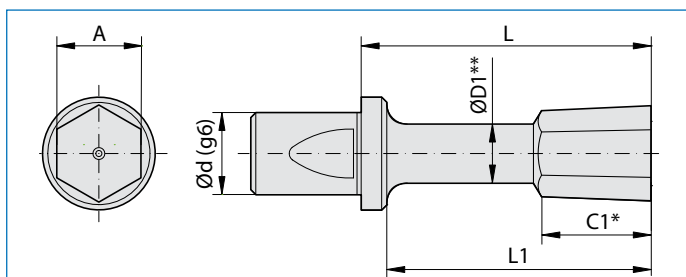

"G12A" - "G12AK" STANDARD
"G12A" - "G12AK" STANDARD

"G12A" - "G12AK" STANDARD
"G12A" - "G12AK" STANDARD

| | |
|------------------|-------------------|
| / | / |
| G12A-E-7 | G12AK-E-7 |
| G12A-E-8 | G12AK-E-8 |
| G12A-E-9 | G12AK-E-9 |
| G12A-E-10 | G12AK-E-10 |
| G12A-E-11 | G12AK-E-11 |
| G12A-E-12 | G12AK-E-12 |
| G12A-E-13 | G12AK-E-13 |
| G12A-E-14 | G12AK-E-14 |
| G12A-E-15 | G12AK-E-15 |

| | |
|-------------------|--------------------|
| G12A-Q-5,5 | G12AK-Q-5,5 |
| G12A-Q-6 | G12AK-Q-6 |
| G12A-Q-7 | G12AK-Q-7 |
| G12A-Q-8 | G12AK-Q-8 |
| G12A-Q-9 | G12AK-Q-9 |
| G12A-Q-10 | G12AK-Q-10 |
| G12A-Q-11 | G12AK-Q-11 |
| G12A-Q-12 | G12AK-Q-12 |
| / | / |

| | | | | | | | | |
|----|-----------------|----|----|----|----|-----|----|---------------------|
| 12 | 5,5 +0,08 +0,10 | 55 | 60 | / | 17 | / | 5 | Standard BR-G12A |
| 12 | 6 +0,08 +0,10 | 55 | 60 | / | 17 | / | 5 | |
| 12 | 7 +0,08 +0,10 | 55 | 60 | 15 | 19 | 6,7 | 5 | |
| 12 | 8 +0,08 +0,10 | 55 | 60 | 17 | 19 | 6,7 | 5 | |
| 12 | 9 +0,09 +0,11 | 55 | 60 | 19 | 21 | 7,7 | 6 | |
| 12 | 10 +0,10 +0,12 | 55 | 60 | 21 | 21 | 7,7 | 7 | |
| 12 | 11 +0,10 +0,12 | 55 | 60 | 21 | 21 | 9,7 | 9 | |
| 12 | 12 +0,11 +0,13 | 55 | 60 | 21 | 21 | 9,7 | 10 | |
| 12 | 13 +0,11 +0,13 | 55 | 60 | 21 | / | 11 | / | |
| 12 | 14 +0,12 +0,14 | 55 | 60 | 21 | / | 12 | / | |
| 12 | 15 +0,13 +0,15 | 55 | 60 | 21 | / | 12 | / | |

C = Profondità utile di brocciatura / C = Depth of the shape
L1 = Profondità max. di lavoro / L1 = Maximum broaching depth

* le quote C1 e C2 possono essere maggiori rispetto alla tabella. In tal caso contattare la Brighetti Meccanica.
the dimensions C1 and C2 may be greater than in the table. In this case, contact Brighetti Meccanica.

** le quote D1 e D2 possono essere modificate a seconda della profondità di lavoro da realizzare. In tal caso contattare la Brighetti Meccanica.
the dimensions D1 and D2 can be modified depending on the working depth to be achieved. In this case, contact Brighetti Meccanica.

In questi articoli possiamo eseguire i seguenti rivestimenti: **HDP RED, WONDER, TiN, INOX PLUS e ZIRINOS** > vedi pag.18
Available coatings for the up above mentioned items: **HDP RED, WONDER, TiN, INOX PLUS and ZIRINOS** > see page 18





BROCCHE G16 - DIAMETRO "d" DEL GAMBO: 16 mm G16 BROACHES - 16 mm SHANK DIAMETER ("d")

Sezione ESAGONALE standard (E) Standard HEXAGONAL section (E)

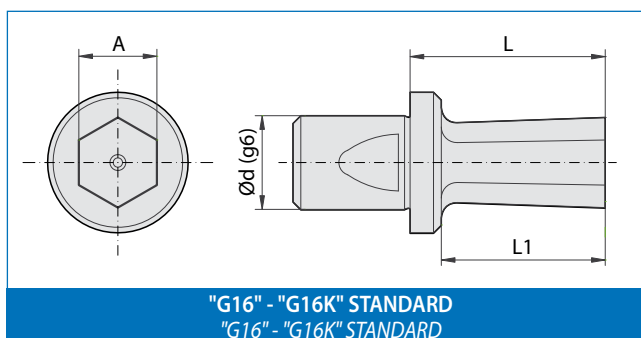

| ARTICOLO (materiale) ITEM (material) | | DIMENSIONI - DIMENSIONS | | | | Utilizzo su Brocciatori/ Use on Broaching heads |
|---|--------------------------|-------------------------|-----------------|----|----|--|
| HSS | SINTERIZZATO SINTERED | d | A | L1 | L | |
| Standard | Standard | d | A | L1 | L | Standard BR-G16 |
| G16-E-2 | G16K-E-2 | 16 | 2 +0,05 +0,07 | 5 | 25 | |
| G16-E-2,5 | G16K-E-2,5 | 16 | 2,5 +0,05 +0,07 | 6 | 25 | |
| G16-E-3 | G16K-E-3 | 16 | 3 +0,06 +0,08 | 7 | 25 | |
| G16-E-3,5 | G16K-E-3,5 | 16 | 3,5 +0,06 +0,08 | 8 | 25 | |
| G16-E-4 | G16K-E-4 | 16 | 4 +0,07 +0,09 | 9 | 25 | |
| G16-E-4,5 | G16K-E-4,5 | 16 | 4,5 +0,07 +0,09 | 9 | 25 | |
| G16-E-5 | G16K-E-5 | 16 | 5 +0,08 +0,10 | 11 | 25 | |
| G16-E-5,5 | G16K-E-5,5 | 16 | 5,5 +0,08 +0,10 | 11 | 25 | |
| G16-E-6 | G16K-E-6 | 16 | 6 +0,08 +0,10 | 13 | 25 | |
| G16-E-7 | G16K-E-7 | 16 | 7 +0,08 +0,10 | 15 | 25 | |
| G16-E-8 | G16K-E-8 | 16 | 8 +0,08 +0,10 | 17 | 25 | |
| G16-E-9 | G16K-E-9 | 16 | 9 +0,09 +0,11 | 19 | 25 | |
| G16-E-10 | G16K-E-10 | 16 | 10 +0,10 +0,12 | 21 | 25 | |
| G16-E-11 | G16K-E-11 | 16 | 11 +0,10 +0,12 | 21 | 25 | |
| G16-E-12 | G16K-E-12 | 16 | 12 +0,11 +0,13 | 21 | 25 | |
| G16-E-13 | G16K-E-13 | 16 | 13 +0,11 +0,13 | 21 | 25 | |
| G16-E-14 | G16K-E-14 | 16 | 14 +0,12 +0,14 | 21 | 25 | |
| G16-E-15 | G16K-E-15 | 16 | 15 +0,13 +0,15 | 21 | 25 | |
| G16-E-16 | G16K-E-16 | 16 | 16 +0,13 +0,15 | 21 | 25 | |
| G16-E-17 | G16K-E-17 | 16 | 17 +0,14 +0,16 | 21 | 25 | |
| G16-E-18 | G16K-E-18 | 16 | 18 +0,15 +0,17 | 21 | 25 | |
| G16-E-19 | G16K-E-19 | 16 | 19 +0,16 +0,18 | 21 | 25 | |
| G16-E-20 | G16K-E-20 | 16 | 20 +0,18 +0,20 | 21 | 25 | |
| G16-E-21 | G16K-E-21 | 16 | 21 +0,18 +0,20 | 21 | 25 | |
| G16-E-22 | G16K-E-22 | 16 | 22 +0,19 +0,21 | 21 | 25 | |
| G16-E-23 | G16K-E-23 | 16 | 23 +0,20 +0,22 | 21 | 25 | |
| G16-E-24 | G16K-E-24 | 16 | 24 +0,21 +0,23 | 21 | 25 | |
| G16-E-25 | G16K-E-25 | 16 | 25 +0,22 +0,24 | 21 | 25 | |

In questi articoli possiamo eseguire i seguenti rivestimenti: **HDP RED, WONDER, TiN, INOX PLUS e ZIRINOS** > vedi pag.18
Available coatings for the up above mentioned items: **HDP RED, WONDER, TiN, INOX PLUS and ZIRINOS** > see page 18





BROCCHE G16 - DIAMETRO "d" DEL GAMBO: 16 mm

G16 BROACHES - 16 mm SHANK DIAMETER ("d")

Sezione QUADRA standard (Q)

Standard SQUARE section (Q)

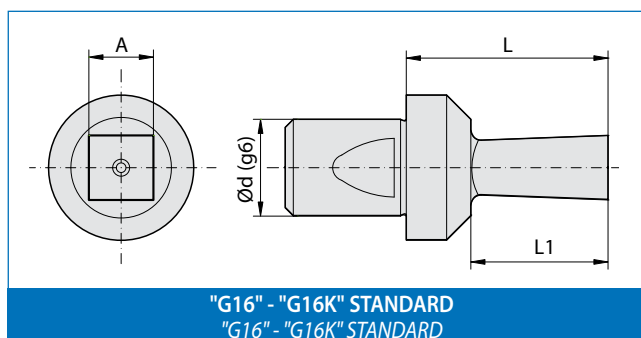

| ARTICOLO (materiale) ITEM (material) | | DIMENSIONI - DIMENSIONS | | | | Utilizzo su Brocciatori/ Use on Broaching heads |
|---|-----------------------------------|-------------------------|-----------------|----|----|--|
| HSS | SINTERIZZATO SINTERED | d | A | L1 | L | |
| Standard <input type="checkbox"/> | Standard <input type="checkbox"/> | | | | | |
| G16-Q-2 | G16K-Q-2 | 16 | 2 +0,05 +0,07 | 5 | 25 | Standard BR-G16 |
| G16-Q-2,5 | G16K-Q-2,5 | 16 | 2,5 +0,05 +0,07 | 6 | 25 | |
| G16-Q-3 | G16K-Q-3 | 16 | 3 +0,06 +0,08 | 7 | 25 | |
| G16-Q-3,5 | G16K-Q-3,5 | 16 | 3,5 +0,07 +0,09 | 8 | 25 | |
| G16-Q-4 | G16K-Q-4 | 16 | 4 +0,07 +0,09 | 9 | 25 | |
| G16-Q-4,5 | G16K-Q-4,5 | 16 | 4,5 +0,07 +0,09 | 9 | 25 | |
| G16-Q-5 | G16K-Q-5 | 16 | 5 +0,08 +0,10 | 11 | 25 | |
| G16-Q-5,5 | G16K-Q-5,5 | 16 | 5,5 +0,08 +0,10 | 11 | 25 | |
| G16-Q-6 | G16K-Q-6 | 16 | 6 +0,08 +0,10 | 13 | 25 | |
| G16-Q-7 | G16K-Q-7 | 16 | 7 +0,08 +0,10 | 15 | 25 | |
| G16-Q-8 | G16K-Q-8 | 16 | 8 +0,08 +0,10 | 17 | 25 | |
| G16-Q-9 | G16K-Q-9 | 16 | 9 +0,09 +0,11 | 19 | 25 | |
| G16-Q-10 | G16K-Q-10 | 16 | 10 +0,10 +0,12 | 21 | 25 | |
| G16-Q-11 | G16K-Q-11 | 16 | 11 +0,10 +0,12 | 21 | 25 | |
| G16-Q-12 | G16K-Q-12 | 16 | 12 +0,11 +0,13 | 21 | 25 | |
| G16-Q-13 | G16K-Q-13 | 16 | 13 +0,11 +0,13 | 21 | 25 | |
| G16-Q-14 | G16K-Q-14 | 16 | 14 +0,12 +0,14 | 21 | 25 | |
| G16-Q-15 | G16K-Q-15 | 16 | 15 +0,13 +0,15 | 21 | 25 | |

In questi articoli possiamo eseguire i seguenti rivestimenti: **HDP RED, WONDER, TiN, INOX PLUS e ZIRINOS** > vedi pag.18
Available coatings for the up above mentioned items: **HDP RED, WONDER, TiN, INOX PLUS and ZIRINOS** > see page 18





BROCCE G16M E G16MC - DIAMETRO "d" DEL GAMBO: 16 mm G16M AND G16MC BROACHES - 16 mm SHANK DIAMETER ("d")

Sezione ESAGONALE (E) HEXAGONAL section (E)

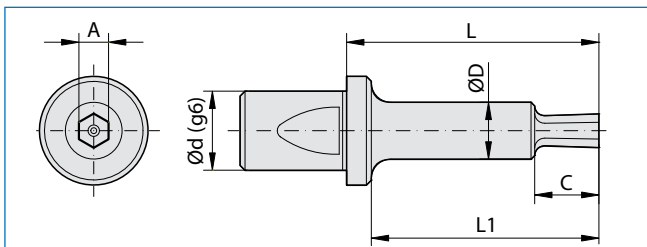

"G16M" - "G16MK" STANDARD
"G16M" - "G16MK" STANDARD

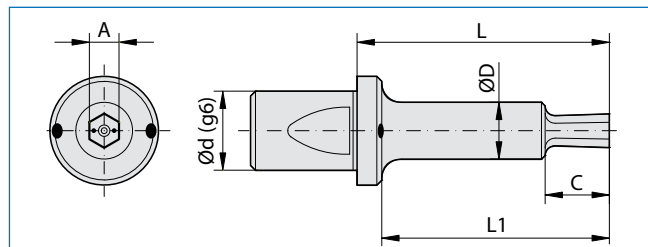

"G16MC" - "G16MKC" CON PASSAGGIO REFRIGERANTE INTERNO
"G16MC" - "G16MKC" WITH INTERNAL FLOW OF COOLANT

| ARTICOLO (materiale) - ITEM (material) | | | | DIMENSIONI - DIMENSIONS | | | | | | Utilizzo su Brocciatori/ Use on Broaching heads |
|--|--------------|-------------------------|--------------|-------------------------|-----------------|----|----|----|-----|--|
| HSS | | SINTERIZZATO / SINTERED | | d | A | L1 | L | C | D | |
| Standard | Ref. / Cool. | Standard | Ref. / Cool. | | | | | | | |
| G16M-E-5 | G16MC-E-5 | G16MK-E-5 | G16MKC-E-5 | 16 | 5 +0,08 +0,10 | 31 | 35 | 11 | 9,4 | Standard BR-G16M |
| G16M-E-5,5 | G16MC-E-5,5 | G16MK-E-5,5 | G16MKC-E-5,5 | 16 | 5,5 +0,08 +0,10 | 31 | 35 | 11 | 9,4 | |
| G16M-E-6 | G16MC-E-6 | G16MK-E-6 | G16MKC-E-6 | 16 | 6 +0,08 +0,10 | 31 | 35 | 13 | 9,4 | Refrig. / Cool. BRC-G16M |
| G16M-E-7 | G16MC-E-7 | G16MK-E-7 | G16MKC-E-7 | 16 | 7 +0,08 +0,10 | 31 | 35 | 15 | 9,4 | |

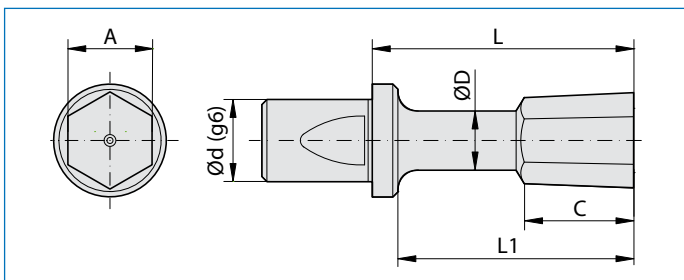

"G16M" - "G16MK" STANDARD
"G16M" - "G16MK" STANDARD

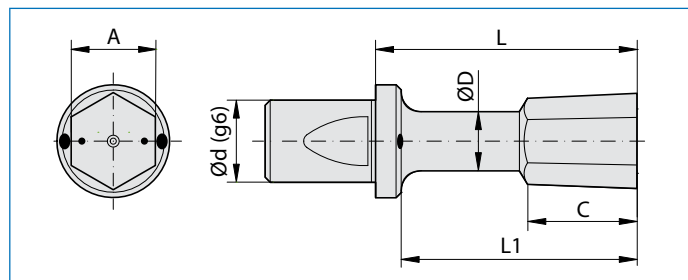

"G16MC" - "G16MKC" CON PASSAGGIO REFRIGERANTE INTERNO
"G16MC" - "G16MKC" WITH INTERNAL FLOW OF COOLANT

| | | | | | | | | | | |
|-----------|------------|------------|-------------|----|----------------|----|----|------|-----|-----------------------------|
| G16M-E-8 | G16MC-E-8 | G16MK-E-8 | G16MKC-E-8 | 16 | 8 +0,08 +0,10 | 31 | 35 | 16 | 5,8 | Standard BR-G16M |
| G16M-E-9 | G16MC-E-9 | G16MK-E-9 | G16MKC-E-9 | 16 | 9 +0,09 +0,11 | 31 | 35 | 15 | 8 | |
| G16M-E-10 | G16MC-E-10 | G16MK-E-10 | G16MKC-E-10 | 16 | 10 +0,10 +0,12 | 31 | 35 | 15 | 8 | Refrig. / Cool. BRC-G16M |
| G16M-E-11 | G16MC-E-11 | G16MK-E-11 | G16MKC-E-11 | 16 | 11 +0,10 +0,12 | 31 | 35 | 15 | 9 | |
| G16M-E-12 | G16MC-E-12 | G16MK-E-12 | G16MKC-E-12 | 16 | 12 +0,11 +0,13 | 31 | 35 | 15 | 10 | Standard BR-G16M |
| G16M-E-13 | G16MC-E-13 | G16MK-E-13 | G16MKC-E-13 | 16 | 13 +0,11 +0,13 | 31 | 35 | 15 | 11 | |
| G16M-E-14 | G16MC-E-14 | G16MK-E-14 | G16MKC-E-14 | 16 | 14 +0,12 +0,14 | 31 | 35 | 15 | 12 | Refrig. / Cool. BRC-G16M |
| G16M-E-15 | G16MC-E-15 | G16MK-E-15 | G16MKC-E-15 | 16 | 15 +0,13 +0,15 | 31 | 35 | 15 | 13 | |
| G16M-E-16 | G16MC-E-16 | G16MK-E-16 | G16MKC-E-16 | 16 | 16 +0,13 +0,15 | 31 | 35 | 15 | 14 | Standard BR-G16M |
| G16M-E-17 | G16MC-E-17 | G16MK-E-17 | G16MKC-E-17 | 16 | 17 +0,14 +0,16 | 31 | 35 | 15 | 15 | |
| G16M-E-18 | G16MC-E-18 | G16MK-E-18 | G16MKC-E-18 | 16 | 18 +0,15 +0,17 | 31 | 35 | 15 | 16 | Refrig. / Cool. BRC-G16M |
| G16M-E-19 | G16MC-E-19 | G16MK-E-19 | G16MKC-E-19 | 16 | 19 +0,16 +0,18 | 31 | 35 | 13,5 | 17 | |
| G16M-E-20 | G16MC-E-20 | G16MK-E-20 | G16MKC-E-20 | 16 | 20 +0,18 +0,20 | 31 | 35 | 13,5 | 18 | Standard BR-G16M |
| G16M-E-21 | G16MC-E-21 | G16MK-E-21 | G16MKC-E-21 | 16 | 21 +0,18 +0,20 | 31 | 35 | 13 | 19 | |
| G16M-E-22 | G16MC-E-22 | G16MK-E-22 | G16MKC-E-22 | 16 | 22 +0,19 +0,21 | 31 | 35 | 13 | 20 | Refrig. / Cool. BRC-G16M |

C = Profondità utile di brocciatura / C = Depth of the shape
L1 = Profondità max. di lavoro / L1 = Maximum broaching depth

segue / continued >>

In questi articoli possiamo eseguire i seguenti rivestimenti: HDP RED, WONDER, TiN, INOX PLUS e ZIRINOS > vedi pag.18
Available coatings for the up above mentioned items: HDP RED, WONDER, TiN, INOX PLUS and ZIRINOS > see page 18



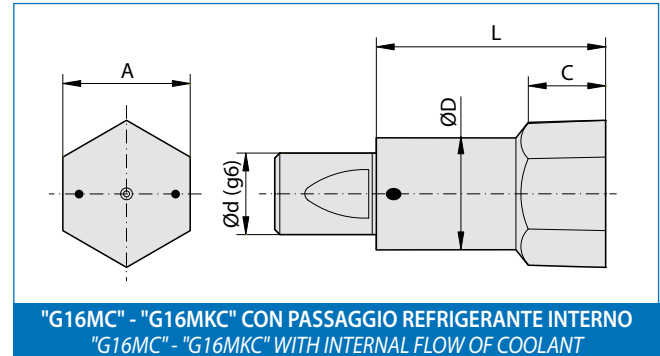
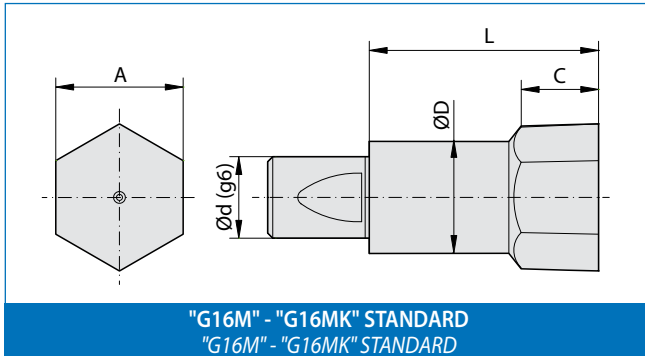

>> segue / continued

BROCCE G16M E G16MC - DIAMETRO "d" DEL GAMBO: 16 mm*G16M AND G16MC BROACHES - 16 mm SHANK DIAMETER ("d")*

| ARTICOLO (materiale) - ITEM (material) | | | | DIMENSIONI - DIMENSIONS | | | | | Utilizzo su Brocciatori/ Use on Broaching heads |
|--|--------------|-------------------------|--------------|-------------------------|----------------|----|------|----|--|
| HSS | | SINTERIZZATO / SINTERED | | d | A | L | C | D | |
| Standard | Ref. / Cool. | Standard | Ref. / Cool. | | | | | | |
| G16M-E-23 | G16MC-E-23 | G16MK-E-23 | G16MKC-E-23 | 16 | 23 +0,20 +0,22 | 35 | 13,2 | 22 | Standard BR-G16M |
| G16M-E-24 | G16MC-E-24 | G16MK-E-24 | G16MKC-E-24 | 16 | 24 +0,21 +0,23 | 35 | 13,2 | 22 | |
| G16M-E-25 | G16MC-E-25 | G16MK-E-25 | G16MKC-E-25 | 16 | 25 +0,22 +0,24 | 35 | 11,5 | 22 | |
| G16M-E-27 | G16MC-E-27 | G16MK-E-27 | G16MKC-E-27 | 16 | 27 +0,22 +0,24 | 35 | 11,5 | 22 | Refrig. / Cool. BRC-G16M |
| G16M-E-28 | G16MC-E-28 | G16MK-E-28 | G16MKC-E-28 | 16 | 28 +0,22 +0,24 | 35 | 11,5 | 22 | |
| G16M-E-30 | G16MC-E-30 | G16MK-E-30 | G16MKC-E-30 | 16 | 30 +0,23 +0,25 | 35 | 11,5 | 22 | |

In questi articoli possiamo eseguire i seguenti rivestimenti: **HDP RED, WONDER, TiN, INOX PLUS e ZIRINOS** > vedi pag.18
 Available coatings for the up above mentioned items: **HDP RED, WONDER, TiN, INOX PLUS and ZIRINOS** > see page 18





BROCCE G16M E G16MC - DIAMETRO "d" DEL GAMBO: 16 mm G16M AND G16MC BROACHES - 16 mm SHANK DIAMETER ("d")

Sezione QUADRA (Q) SQUARE section (Q)

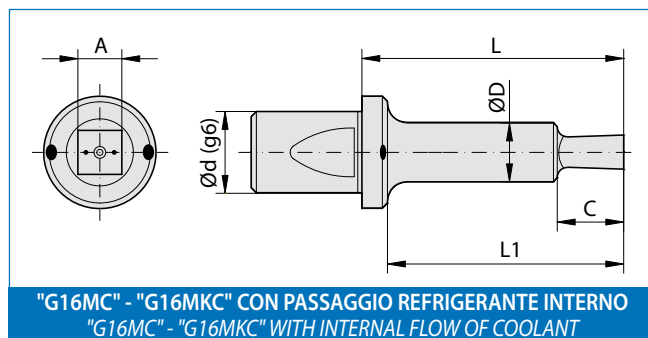
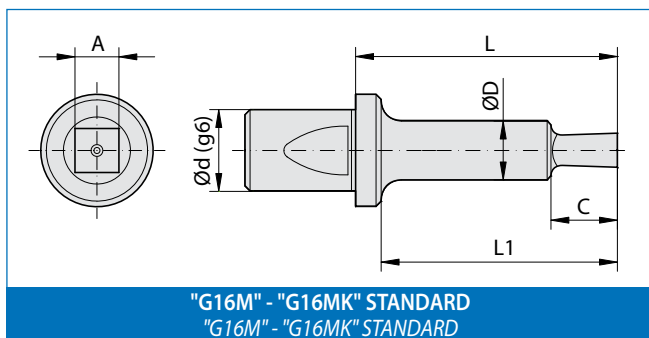

| ARTICOLO (materiale) - ITEM (material) | | | | DIMENSIONI - DIMENSIONS | | | | | | Utilizzo su Broccatori/ Use on Broaching heads |
|--|--------------------------|-------------------------|--------------------------|-------------------------|--------------------------|--------------|--------------------------|----|----|--|
| HSS | | SINTERIZZATO / SINTERED | | d | A | L1 | L | C | D | |
| Standard | <input type="checkbox"/> | Ref. / Cool. | <input type="checkbox"/> | Standard | <input type="checkbox"/> | Ref. / Cool. | <input type="checkbox"/> | | | |
| G16M-Q-5 | | / | | G16MK-Q-5 | | / | | | | Standard BR-G16M Refrig. / Cool. BRC-G16M |
| G16M-Q-5,5 | | / | | G16MK-Q-5,5 | | / | | | | |
| G16M-Q-6 | G16MC-Q-6 | G16MK-Q-6 | G16MKC-Q-6 | 16 | 5 | +0,08 +0,10 | 11 | 35 | 11 | |

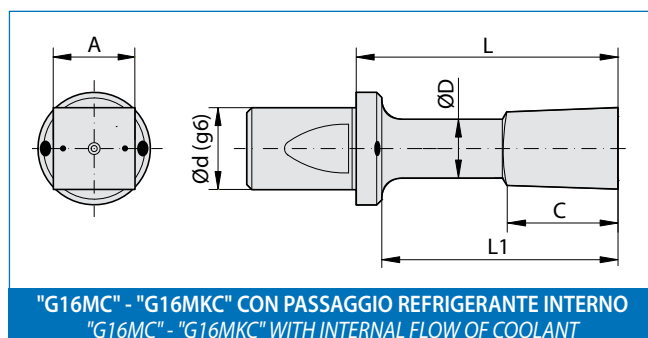
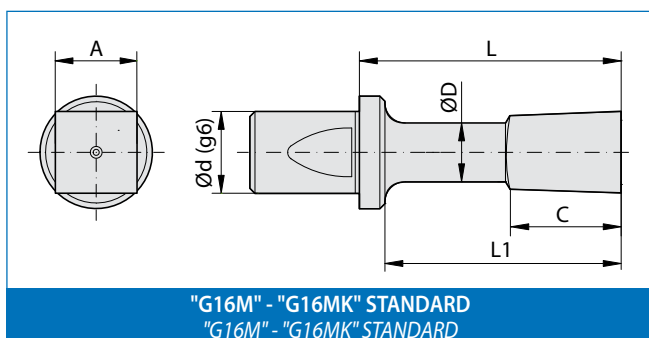

| | | | | | | | | | | | |
|-----------|------------|------------|-------------|----|----|-------------|----|----|------|-----|--|
| G16M-Q-7 | G16MC-Q-7 | G16MK-Q-7 | G16MKC-Q-7 | 16 | 7 | +0,08 +0,10 | 31 | 35 | 14 | 4,2 | Standard BR-G16M Refrig. / Cool. BRC-G16M |
| G16M-Q-8 | G16MC-Q-8 | G16MK-Q-8 | G16MKC-Q-8 | 16 | 8 | +0,08 +0,10 | 31 | 35 | 14,5 | 5 | |
| G16M-Q-9 | G16MC-Q-9 | G16MK-Q-9 | G16MKC-Q-9 | 16 | 9 | +0,09 +0,11 | 31 | 35 | 14,5 | 6 | |
| G16M-Q-10 | G16MC-Q-10 | G16MK-Q-10 | G16MKC-Q-10 | 16 | 10 | +0,10 +0,12 | 31 | 35 | 14,5 | 7,2 | |
| G16M-Q-11 | G16MC-Q-11 | G16MK-Q-11 | G16MKC-Q-11 | 16 | 11 | +0,10 +0,12 | 31 | 35 | 15 | 8 | |
| G16M-Q-12 | G16MC-Q-12 | G16MK-Q-12 | G16MKC-Q-12 | 16 | 12 | +0,11 +0,13 | 31 | 35 | 15 | 9 | |
| G16M-Q-13 | G16MC-Q-13 | G16MK-Q-13 | G16MKC-Q-13 | 16 | 13 | +0,11 +0,13 | 31 | 35 | 13,5 | 10 | |
| G16M-Q-14 | G16MC-Q-14 | G16MK-Q-14 | G16MKC-Q-14 | 16 | 14 | +0,12 +0,14 | 31 | 35 | 13,5 | 11 | |
| G16M-Q-15 | G16MC-Q-15 | G16MK-Q-15 | G16MKC-Q-15 | 16 | 15 | +0,13 +0,15 | 31 | 35 | 13,5 | 12 | |
| G16M-Q-16 | G16MC-Q-16 | G16MK-Q-16 | G16MKC-Q-16 | 16 | 16 | +0,13 +0,15 | 31 | 35 | 13,5 | 13 | |
| G16M-Q-17 | G16MC-Q-17 | G16MK-Q-17 | G16MKC-Q-17 | 16 | 17 | +0,14 +0,16 | 31 | 35 | 13 | 14 | |
| G16M-Q-18 | G16MC-Q-18 | G16MK-Q-18 | G16MKC-Q-18 | 16 | 18 | +0,15 +0,17 | 31 | 35 | 13 | 15 | |
| G16M-Q-19 | G16MC-Q-19 | G16MK-Q-19 | G16MKC-Q-19 | 16 | 19 | +0,16 +0,18 | 31 | 35 | 13 | 16 | |
| G16M-Q-20 | G16MC-Q-20 | G16MK-Q-20 | G16MKC-Q-20 | 16 | 20 | +0,18 +0,20 | 31 | 35 | 13 | 17 | |

C = Profondità utile di brocciatura / C = Depth of the shape
L1 = Profondità max. di lavoro / L1 = Maximum broaching depth

In questi articoli possiamo eseguire i seguenti rivestimenti: HDP RED, WONDER, TiN, INOX PLUS e ZIRINOS > vedi pag.18
Available coatings for the up above mentioned items: HDP RED, WONDER, TiN, INOX PLUS and ZIRINOS > see page 18





BROCCE G16L E G16LC - DIAMETRO "d" DEL GAMBO: 16 mm G16L AND G16LC BROACHES - 16 mm SHANK DIAMETER ("d")

Sezione ESAGONALE (E) HEXAGONAL section (E)

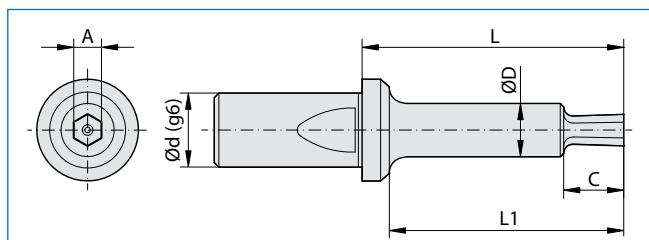

"G16L" - "G16LK" STANDARD
"G16L" - "G16LK" STANDARD

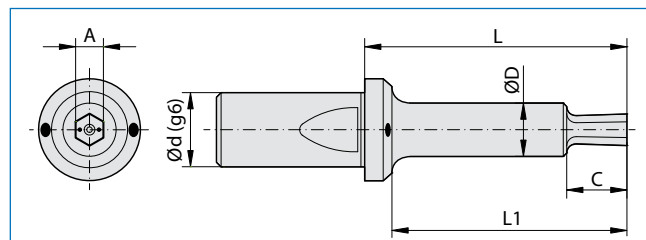

"G16LC" - "G16LKC" CON PASSAGGIO REFRIGERANTE INTERNO
"G16LC" - "G16LKC" WITH INTERNAL FLOW OF COOLANT

| ARTICOLO (materiale) - ITEM (material) | | | | DIMENSIONI - DIMENSIONS | | | | | | Utilizzo su Broccatori / Use on Broaching heads |
|--|--------------|-------------------------|--------------|-------------------------|---------------|----|----|----|-----|---|
| HSS | | SINTERIZZATO / SINTERED | | d | A | L1 | L | C | D | |
| Standard | Ref. / Cool. | Standard | Ref. / Cool. | | | | | | | |
| G16L-E-4 | / | G16LK-E-4 | / | 16 | 4 +0,07 +0,09 | 41 | 45 | 9 | 7,5 | |
| G16L-E-5 | | G16LK-E-5 | | 16 | 5 +0,08 +0,10 | 41 | 45 | 13 | 9 | |
| G16L-E-6 | | G16LK-E-6 | | 16 | 6 +0,08 +0,10 | 41 | 45 | 15 | 9 | |
| G16L-E-7 | | G16LK-E-7 | | 16 | 7 +0,08 +0,10 | 41 | 45 | 16 | 6,5 | |
| G16L-E-8 | G16LC-E-8 | G16LK-E-8 | G16LKC-E-8 | 16 | 8 +0,08 +0,10 | 41 | 45 | 16 | 6,5 | |
| G16L-E-9 | G16LC-E-9 | G16LK-E-9 | G16LKC-E-9 | 16 | 9 +0,09 +0,11 | 41 | 45 | 16 | 6,5 | |

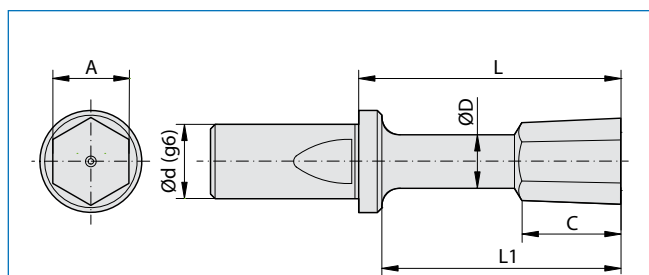

"G16L" - "G16LK" STANDARD
"G16L" - "G16LK" STANDARD

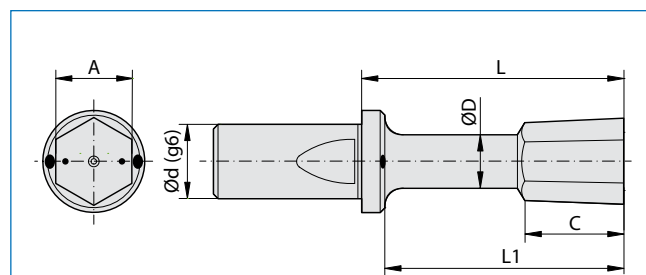

"G16LC" - "G16LKC" CON PASSAGGIO REFRIGERANTE INTERNO
"G16LC" - "G16LKC" WITH INTERNAL FLOW OF COOLANT

| | | | | | | | | | |
|-----------|------------|------------|-------------|----|----------------|----|----|----|----|
| G16L-E-10 | G16LC-E-10 | G16LK-E-10 | G16LKC-E-10 | 16 | 10 +0,10 +0,12 | 41 | 45 | 15 | 7 |
| G16L-E-11 | G16LC-E-11 | G16LK-E-11 | G16LKC-E-11 | 16 | 11 +0,10 +0,12 | 41 | 45 | 15 | 8 |
| G16L-E-12 | G16LC-E-12 | G16LK-E-12 | G16LKC-E-12 | 16 | 12 +0,11 +0,13 | 41 | 45 | 15 | 9 |
| G16L-E-13 | G16LC-E-13 | G16LK-E-13 | G16LKC-E-13 | 16 | 13 +0,11 +0,13 | 41 | 45 | 15 | 10 |
| G16L-E-14 | G16LC-E-14 | G16LK-E-14 | G16LKC-E-14 | 16 | 14 +0,12 +0,14 | 41 | 45 | 15 | 11 |
| G16L-E-15 | G16LC-E-15 | G16LK-E-15 | G16LKC-E-15 | 16 | 15 +0,13 +0,15 | 41 | 45 | 15 | 12 |
| G16L-E-16 | G16LC-E-16 | G16LK-E-16 | G16LKC-E-16 | 16 | 16 +0,13 +0,15 | 41 | 45 | 15 | 13 |
| G16L-E-17 | G16LC-E-17 | G16LK-E-17 | G16LKC-E-17 | 16 | 17 +0,14 +0,16 | 41 | 45 | 15 | 14 |
| G16L-E-18 | G16LC-E-18 | G16LK-E-18 | G16LKC-E-18 | 16 | 18 +0,15 +0,17 | 41 | 45 | 15 | 15 |
| G16L-E-19 | G16LC-E-19 | G16LK-E-19 | G16LKC-E-19 | 16 | 19 +0,16 +0,18 | 41 | 45 | 15 | 16 |
| G16L-E-20 | G16LC-E-20 | G16LK-E-20 | G16LKC-E-20 | 16 | 20 +0,18 +0,20 | 41 | 45 | 17 | 17 |
| G16L-E-21 | G16LC-E-21 | G16LK-E-21 | G16LKC-E-21 | 16 | 21 +0,18 +0,20 | 41 | 45 | 17 | 18 |
| G16L-E-22 | G16LC-E-22 | G16LK-E-22 | G16LKC-E-22 | 16 | 22 +0,19 +0,21 | 41 | 45 | 17 | 19 |
| G16L-E-23 | G16LC-E-23 | G16LK-E-23 | G16LKC-E-23 | 16 | 23 +0,20 +0,22 | 41 | 45 | 17 | 20 |
| G16L-E-24 | G16LC-E-24 | G16LK-E-24 | G16LKC-E-24 | 16 | 24 +0,21 +0,23 | 41 | 45 | 17 | 21 |

Standard
BR-G16L
Refrig. / Cool.
BRC-G16L

C = Profondità utile di brocciatura / C = Depth of the shape
L1 = Profondità max. di lavoro / L1 = Maximum broaching depth

segue / continued >>

In questi articoli possiamo eseguire i seguenti rivestimenti: HDP RED, WONDER, TiN, INOX PLUS e ZIRINOS > vedi pag.18
Available coatings for the up above mentioned items: HDP RED, WONDER, TiN, INOX PLUS and ZIRINOS > see page 18



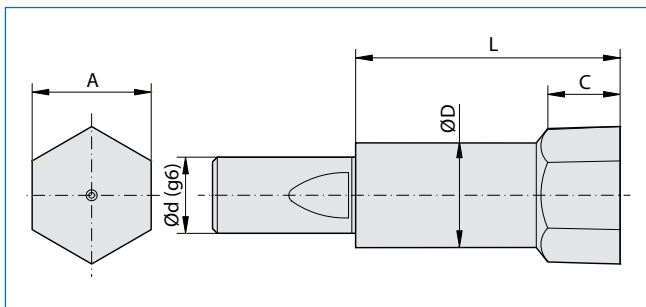

>> segue / continued

BROCCHE G16M E G16MC - DIAMETRO "d" DEL GAMBO: 16 mm*G16M AND G16MC BROACHES - 16 mm SHANK DIAMETER ("d")*

"G16L" - "G16LK" STANDARD
"G16L" - "G16LK" STANDARD

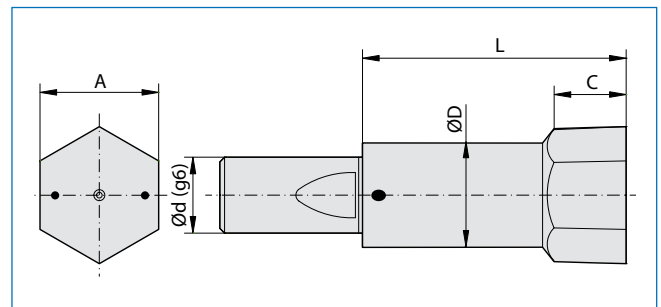

"G16LC" - "G16LKC" CON PASSAGGIO REFRIGERANTE INTERNO
"G16LC" - "G16LKC" WITH INTERNAL FLOW OF COOLANT

| ARTICOLO (materiale) - ITEM (material) | | | | DIMENSIONI - DIMENSIONS | | | | | Utilizzo su Broccatori / Use on Broaching heads |
|--|--------------|-------------------------|--------------|-------------------------|----------------|----|----|----|--|
| HSS | | SINTERIZZATO / SINTERED | | d | A | L | C | D | |
| Standard | Ref. / Cool. | Standard | Ref. / Cool. | | | | | | |
| G16L-E-25 | G16LC-E-25 | G16LK-E-25 | G16LKC-E-25 | 16 | 25 +0,22 +0,24 | 45 | 17 | 22 | Standard BR-G16L Refrig. / Cool. BRC-G16L |
| G16L-E-27 | G16LC-E-27 | G16LK-E-27 | G16LKC-E-27 | 16 | 27 +0,22 +0,24 | 45 | 17 | 22 | |
| G16L-E-28 | G16LC-E-28 | G16LK-E-28 | G16LKC-E-28 | 16 | 28 +0,22 +0,24 | 45 | 17 | 22 | |
| G16L-E-30 | G16LC-E-30 | G16LK-E-30 | G16LKC-E-30 | 16 | 30 +0,23 +0,25 | 45 | 17 | 22 | |

C = Profondità utile di brocciatura / C = Depth of the shape

L1 = Profondità max. di lavoro / L1 = Maximum broaching depth



BROCCE G16L E G16LC - DIAMETRO "d" DEL GAMBO: 16 mm G16L AND G16LC BROACHES - 16 mm SHANK DIAMETER ("d")

Sezione QUADRA (Q) SQUARE section (Q)

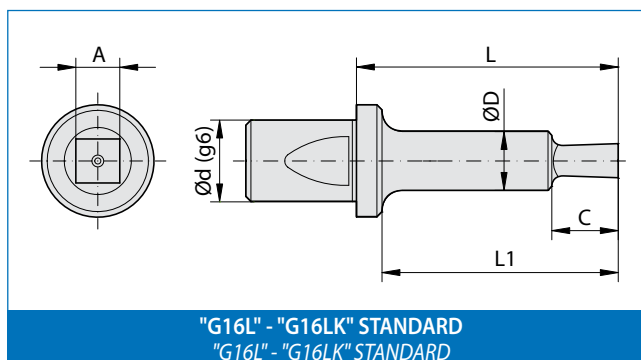

"G16L" - "G16LK" STANDARD
"G16L" - "G16LK" STANDARD

| ARTICOLO (materiale) - ITEM (material) | | | | DIMENSIONI - DIMENSIONS | | | | | | Utilizzo su Brocciatori/ Use on Broaching heads |
|--|---------------------------------------|-----------------------------------|---------------------------------------|-------------------------|---------------|----|----|----|-----|--|
| HSS | | SINTERIZZATO / SINTERED | | d | A | L1 | L | C | D | |
| Standard <input type="checkbox"/> | Ref. / Cool. <input type="checkbox"/> | Standard <input type="checkbox"/> | Ref. / Cool. <input type="checkbox"/> | | | | | | | Standard BR-G16L Refrig. / Cool. BRC-G16L |
| G16L-Q-6 | / | G16LK-Q-6 | / | 16 | 6 +0,08 +0,10 | 41 | 45 | 15 | 7,5 | |
| G16L-Q-7 | | G16LK-Q-7 | | 16 | 7 +0,08 +0,10 | 41 | 45 | 15 | 6 | |
| G16L-Q-8 | | G16LK-Q-8 | | 16 | 8 +0,08 +0,10 | 41 | 45 | 15 | 7 | |
| G16L-Q-9 | | G16LK-Q-9 | | 16 | 9 +0,09 +0,11 | 41 | 45 | 15 | 8 | |

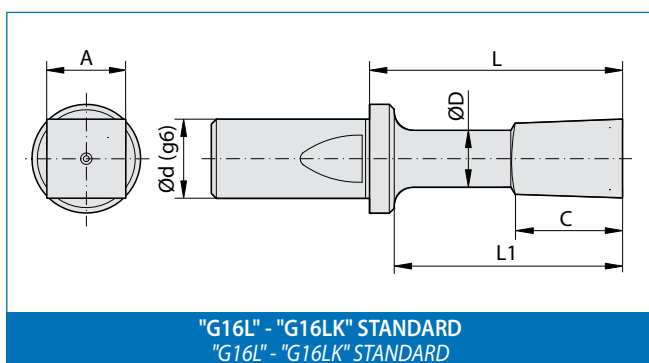

"G16L" - "G16LK" STANDARD
"G16L" - "G16LK" STANDARD

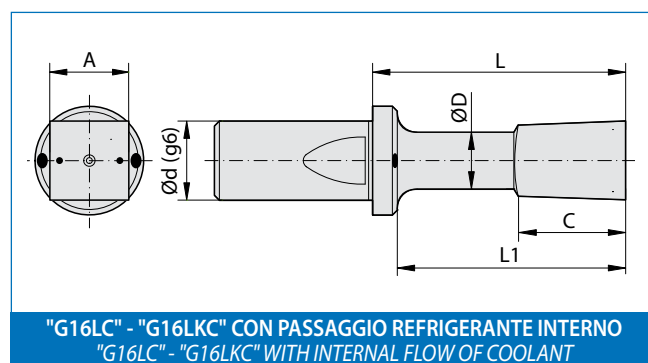

"G16LC" - "G16LKC" CON PASSAGGIO REFRIGERANTE INTERNO
"G16LC" - "G16LKC" WITH INTERNAL FLOW OF COOLANT

| | | | | | | | | | | |
|-----------|------------|------------|-------------|----|----------------|----|----|------|------|--|
| G16L-Q-10 | G16LC-Q-10 | G16LK-Q-10 | G16LKC-Q-10 | 16 | 10 +0,10 +0,12 | 41 | 45 | 17 | 7,2 | Standard BR-G16L Refrig. / Cool. BRC-G16L |
| G16L-Q-11 | G16LC-Q-11 | G16LK-Q-11 | G16LKC-Q-11 | 16 | 11 +0,10 +0,12 | 41 | 45 | 17 | 8 | |
| G16L-Q-12 | G16LC-Q-12 | G16LK-Q-12 | G16LKC-Q-12 | 16 | 12 +0,11 +0,13 | 41 | 45 | 17 | 9 | |
| G16L-Q-13 | G16LC-Q-13 | G16LK-Q-13 | G16LKC-Q-13 | 16 | 13 +0,11 +0,13 | 41 | 45 | 18 | 10 | |
| G16L-Q-14 | G16LC-Q-14 | G16LK-Q-14 | G16LKC-Q-14 | 16 | 14 +0,12 +0,14 | 41 | 45 | 18 | 11 | |
| G16L-Q-15 | G16LC-Q-15 | G16LK-Q-15 | G16LKC-Q-15 | 16 | 15 +0,13 +0,15 | 41 | 45 | 18 | 12 | |
| G16L-Q-16 | G16LC-Q-16 | G16LK-Q-16 | G16LKC-Q-16 | 16 | 16 +0,13 +0,15 | 41 | 45 | 18 | 13 | |
| G16L-Q-17 | G16LC-Q-17 | G16LK-Q-17 | G16LKC-Q-17 | 16 | 17 +0,14 +0,16 | 41 | 45 | 18 | 14 | |
| G16L-Q-18 | G16LC-Q-18 | G16LK-Q-18 | G16LKC-Q-18 | 16 | 18 +0,15 +0,17 | 41 | 45 | 17 | 15 | |
| G16L-Q-19 | G16LC-Q-19 | G16LK-Q-19 | G16LKC-Q-19 | 16 | 19 +0,16 +0,18 | 41 | 45 | 17 | 16 | |
| G16L-Q-20 | G16LC-Q-20 | G16LK-Q-20 | G16LKC-Q-20 | 16 | 20 +0,18 +0,20 | 41 | 45 | 17 | 17 | |
| G16L-Q-21 | G16LC-Q-21 | G16LK-Q-21 | G16LKC-Q-21 | 16 | 21 +0,18 +0,20 | 41 | 45 | 17 | 18 | |
| G16L-Q-22 | G16LC-Q-22 | G16LK-Q-22 | G16LKC-Q-22 | 16 | 22 +0,19 +0,21 | 41 | 45 | 16,5 | 18,5 | |
| G16L-Q-23 | G16LC-Q-23 | G16LK-Q-23 | G16LKC-Q-23 | 16 | 23 +0,20 +0,22 | 41 | 45 | 16,5 | 19,5 | |

C = Profondità utile di brocciatura / C = Depth of the shape

L1 = Profondità max. di lavoro / L1 = Maximum broaching depth

In questi articoli possiamo eseguire i seguenti rivestimenti: HDP RED, WONDER, TiN, INOX PLUS e ZIRINOS > vedi pag.18
Available coatings for the up above mentioned items: HDP RED, WONDER, TiN, INOX PLUS and ZIRINOS > see page 18





>> segue / continued

BROCCHE G16L E G16LC - DIAMETRO "d" DEL GAMBO: 16 mm
G16L AND G16LC BROACHES - 16 mm SHANK DIAMETER ("d")

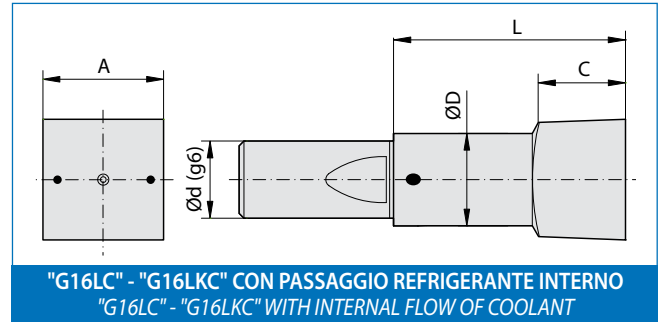
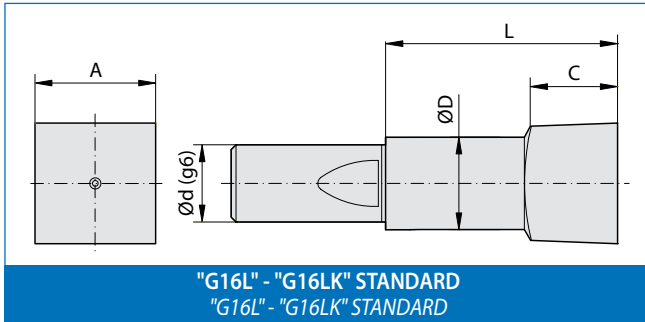

| ARTICOLO (materiale) - ITEM (material) | | | | DIMENSIONI - DIMENSIONS | | | | | | Utilizzo su Brocciatori/ Use on Broaching heads |
|--|---------------------------------------|-----------------------------------|---------------------------------------|-------------------------|----------------|----|----|----|----|--|
| HSS | | SINTERIZZATO / SINTERED | | d | A | L1 | L | C | D | |
| Standard <input type="checkbox"/> | Ref. / Cool. <input type="checkbox"/> | Standard <input type="checkbox"/> | Ref. / Cool. <input type="checkbox"/> | | | | | | | |
| G16L-Q-24 | G16LC-Q-24 | G16LK-Q-24 | G16LKC-Q-24 | 16 | 24 +0,21 +0,23 | / | 45 | 16 | 20 | Standard BR-G16L |
| G16L-Q-25 | G16LC-Q-25 | G16LK-Q-25 | G16LKC-Q-25 | 16 | 25 +0,22 +0,24 | / | 45 | 16 | 21 | |
| | | | | | | | | | | Refrig. / Cool. BRC-G16L |

C = Profondità utile di brocciatura / C = Depth of the shape
 L1 = Profondità max. di lavoro / L1 = Maximum broaching depth



BROCCE G25 - DIAMETRO "d" DEL GAMBO: 25 mm

G25 BROACHES - 25 mm SHANK DIAMETER ("d")

Sezione ESAGONALE standard (E)

Standard HEXAGONAL section (E)

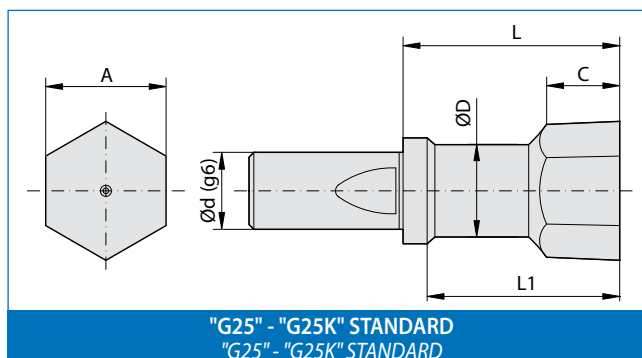

| ARTICOLO (materiale) ITEM (material) | | DIMENSIONI - DIMENSIONS | | | | | | | Utilizzo su Brocciatori/ Use on Broaching heads |
|---|--------------------------|-------------------------|----------------|----|----|----|----|--------------------|--|
| HSS | SINTERIZZATO SINTERED | d | A | L1 | L | C | D | | |
| Standard | Standard | | | | | | | | |
| G25-E-15 | G25K-E-15 | 25 | 15 +0,13 +0,15 | 65 | 70 | 30 | 10 | Standard BR-G25 | |
| G25-E-16 | G25K-E-16 | 25 | 16 +0,13 +0,15 | 65 | 70 | 30 | 11 | | |
| G25-E-17 | G25K-E-17 | 25 | 17 +0,14 +0,16 | 65 | 70 | 30 | 12 | | |
| G25-E-18 | G25K-E-18 | 25 | 18 +0,15 +0,17 | 65 | 70 | 30 | 13 | | |
| G25-E-19 | G25K-E-19 | 25 | 19 +0,16 +0,18 | 65 | 70 | 30 | 14 | | |
| G25-E-20 | G25K-E-20 | 25 | 20 +0,18 +0,20 | 65 | 70 | 30 | 15 | | |
| G25-E-21 | G25K-E-21 | 25 | 21 +0,18 +0,20 | 65 | 70 | 25 | 16 | | |
| G25-E-22 | G25K-E-22 | 25 | 22 +0,20 +0,22 | 65 | 70 | 25 | 17 | | |
| G25-E-23 | G25K-E-23 | 25 | 23 +0,20 +0,22 | 65 | 70 | 25 | 18 | | |
| G25-E-24 | G25K-E-24 | 25 | 24 +0,21 +0,23 | 65 | 70 | 25 | 19 | | |
| G25-E-25 | G25K-E-25 | 25 | 25 +0,22 +0,24 | 65 | 70 | 25 | 20 | | |
| G25-E-26 | G25K-E-26 | 25 | 26 +0,22 +0,24 | 65 | 70 | 25 | 21 | | |
| G25-E-27 | G25K-E-27 | 25 | 27 +0,22 +0,24 | 65 | 70 | 25 | 22 | | |
| G25-E-28 | G25K-E-28 | 25 | 28 +0,22 +0,24 | 65 | 70 | 28 | 23 | | |
| G25-E-29 | G25K-E-29 | 25 | 29 +0,22 +0,24 | 65 | 70 | 25 | 24 | | |
| G25-E-30 | G25K-E-30 | 25 | 30 +0,23 +0,25 | 65 | 70 | 25 | 25 | | |
| G25-E-31 | G25K-E-31 | 25 | 31 +0,23 +0,25 | 65 | 70 | 25 | 26 | | |
| G25-E-32 | G25K-E-32 | 25 | 32 +0,23 +0,25 | 65 | 70 | 25 | 27 | | |
| G25-E-33 | G25K-E-33 | 25 | 33 +0,23 +0,25 | 65 | 70 | 25 | 28 | | |
| G25-E-34 | G25K-E-34 | 25 | 34 +0,23 +0,25 | 65 | 70 | 25 | 29 | | |
| G25-E-35 | G25K-E-35 | 25 | 35 +0,24 +0,26 | 65 | 70 | 25 | 30 | | |
| G25-E-36 | G25K-E-36 | 25 | 36 +0,24 +0,26 | 65 | 70 | 25 | 31 | | |

ARTICOLI SPECIALI
A RICHIESTA
SPECIAL ITEMS ON
REQUEST

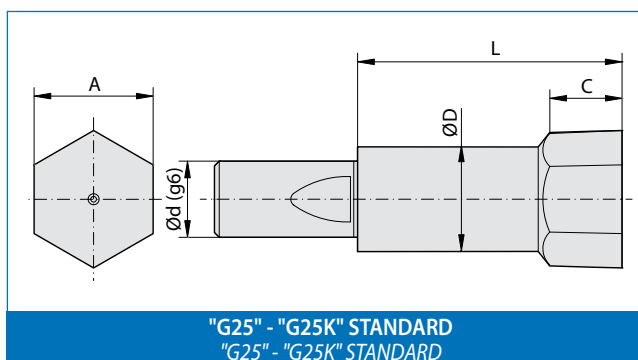

ARTICOLI SPECIALI
A RICHIESTA
SPECIAL ITEMS ON
REQUEST

| | | | | | | | | |
|----------|-----------|----|----------------|---|----|----|----|--------------------|
| G25-E-37 | G25K-E-37 | 25 | 37 +0,24 +0,26 | - | 70 | 22 | 32 | Standard BR-G25 |
| G25-E-38 | G25K-E-38 | 25 | 38 +0,24 +0,26 | - | 70 | 22 | 32 | |
| G25-E-39 | G25K-E-39 | 25 | 39 +0,24 +0,26 | - | 70 | 22 | 32 | |



BROCCHE G25 - DIAMETRO "d" DEL GAMBO: 25 mm G25 BROACHES - 25 mm SHANK DIAMETER ("d")

Sezione QUADRA standard (Q) Standard SQUARE section (Q)

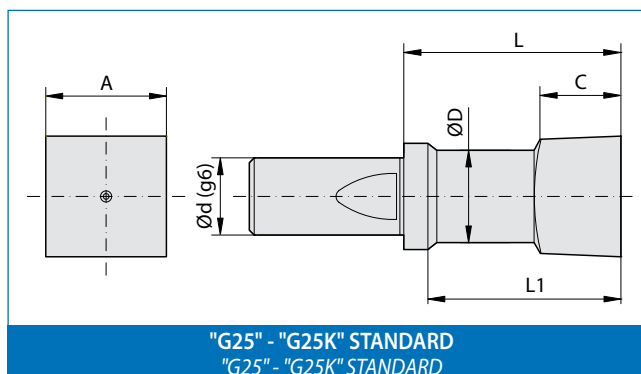

| ARTICOLO (materiale) ITEM (material) | | DIMENSIONI - DIMENSIONS | | | | | | | Utilizzo su Brocciatori/ Use on Broaching heads |
|---|-----------------------------------|-------------------------|----------------|----|----|----|------|--------------------|--|
| HSS | SINTERIZZATO SINTERED | d | A | L1 | L | C | D | | |
| Standard <input type="checkbox"/> | Standard <input type="checkbox"/> | | | | | | | | |
| G25-Q-15 | G25K-Q-15 | 25 | 15 +0,13 +0,15 | 65 | 70 | 30 | 10,5 | Standard BR-G25 | |
| G25-Q-16 | G25K-Q-16 | 25 | 16 +0,13 +0,15 | 65 | 70 | 30 | 11,5 | | |
| G25-Q-17 | G25K-Q-17 | 25 | 17 +0,14 +0,16 | 65 | 70 | 30 | 12,5 | | |
| G25-Q-18 | G25K-Q-18 | 25 | 18 +0,15 +0,17 | 65 | 70 | 30 | 13,5 | | |
| G25-Q-19 | G25K-Q-19 | 25 | 19 +0,16 +0,18 | 65 | 70 | 30 | 14,5 | | |
| G25-Q-20 | G25K-Q-20 | 25 | 20 +0,18 +0,20 | 65 | 70 | 30 | 15,5 | | |
| G25-Q-21 | G25K-Q-21 | 25 | 21 +0,18 +0,20 | 65 | 70 | 30 | 16,5 | | |
| G25-Q-22 | G25K-Q-22 | 25 | 22 +0,20 +0,22 | 65 | 70 | 30 | 17,5 | | |
| G25-Q-23 | G25K-Q-23 | 25 | 23 +0,20 +0,22 | 65 | 70 | 30 | 18,5 | | |
| G25-Q-24 | G25K-Q-24 | 25 | 24 +0,21 +0,23 | 65 | 70 | 30 | 19,5 | | |
| G25-Q-25 | G25K-Q-25 | 25 | 25 +0,22 +0,24 | 65 | 70 | 30 | 20,5 | | |

ARTICOLI SPECIALI
A RICHIESTA
SPECIAL ITEMS ON
REQUEST

C = Profondità utile di brocciatura / C = Depth of the shape
L1 = Profondità max. di lavoro / L1 = Maximum broaching depth

In questi articoli possiamo eseguire i seguenti rivestimenti: **HDP RED, WONDER, TiN, INOX PLUS e ZIRINOS** > vedi pag.18
Available coatings for the up above mentioned items: **HDP RED, WONDER, TiN, INOX PLUS and ZIRINOS** > see page 18





Brocche Standard per cave poligonali su Brocciatori serie "BR" e "BRC" - Misure in pollici

Standard Broaches for polygonal holes on broaching heads "BR" and "BRC" series - Size in inches

BROCCE GP8 E GP8C - DIAMETRO "d" DEL GAMBO: 8 mm - MISURE IN POLLICI
GP8 AND GP8C BROACHES - 8 mm SHANK DIAMETER ("d") - SIZES IN INCHES

Sezione ESAGONALE (E) / HEXAGONAL section (E)

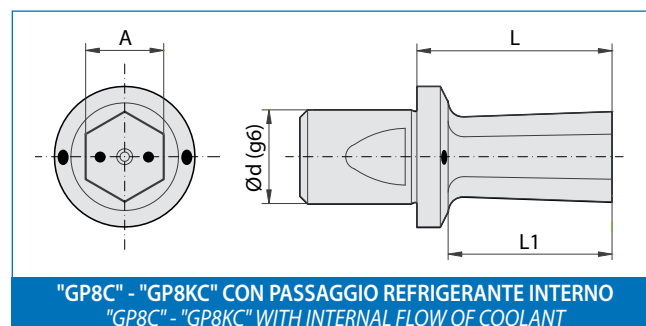
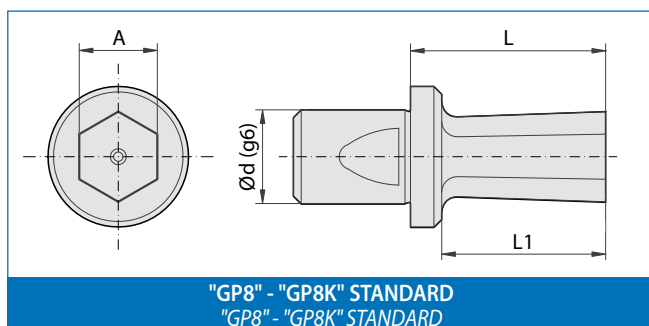

| ARTICOLO (materiale) - ITEM (material) | | | | DIMENSIONI - DIMENSIONS | | | | Utilizzo su Brocciatori/ Use on Broaching heads |
|--|--------------|-------------------------|---------------|-------------------------|------------------|----|----|--|
| HSS | | SINTERIZZATO / SINTERED | | d | A | L1 | L | |
| Standard | Ref. / Cool. | Standard | Ref. / Cool. | | | | | |
| GP8-E-3/32" | / | GP8K-E-3/32" | / | 8 | 2,38 +0,06 +0,08 | 5 | 18 | Standard BR-G8S BR-G8M BR-G8 BR-G8A |
| GP8-E-1/8" | GP8C-E-1/8" | GP8K-E-1/8" | GP8KC-E-1/8" | 8 | 3,17 +0,07 +0,09 | 6 | 18 | Refrig. / Cool. BRC-G8M BRC-G8 BRC-G8HP |
| GP8-E-5/32" | GP8C-E-5/32" | GP8K-E-5/32" | GP8KC-E-5/32" | 8 | 3,97 +0,08 +0,10 | 8 | 18 | |
| GP8-E-3/16" | GP8C-E-3/16" | GP8K-E-3/16" | GP8KC-E-3/16" | 8 | 4,76 +0,08 +0,10 | 9 | 18 | |
| GP8-E-7/32" | GP8C-E-7/32" | GP8K-E-7/32" | GP8KC-E-7/32" | 8 | 5,55 +0,08 +0,10 | 11 | 18 | |
| GP8-E-1/4" | GP8C-E-1/4" | GP8K-E-1/4" | GP8KC-E-1/4" | 8 | 6,35 +0,08 +0,10 | 13 | 18 | |

Sezione QUADRA (Q) / SQUARE section (Q)

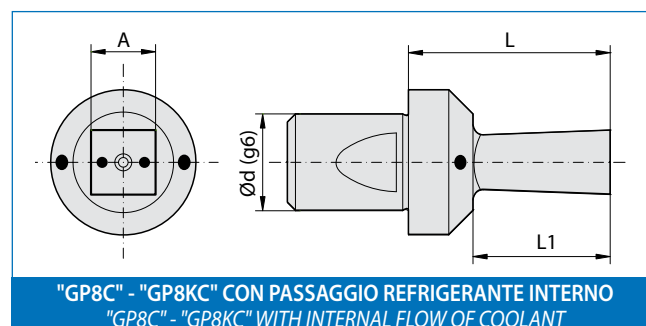
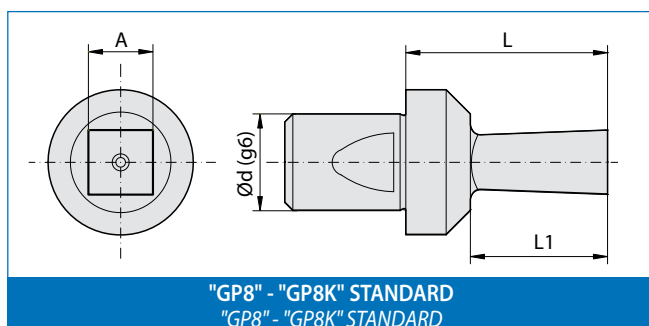

| ARTICOLO (materiale) - ITEM (material) | | | | DIMENSIONI - DIMENSIONS | | | | Utilizzo su Brocciatori/ Use on Broaching heads |
|--|--------------|-------------------------|---------------|-------------------------|------------------|----|----|--|
| HSS | | SINTERIZZATO / SINTERED | | d | A | L1 | L | |
| Standard | Ref. / Cool. | Standard | Ref. / Cool. | | | | | |
| GP8-Q-3/32" | / | GP8K-Q-3/32" | / | 8 | 2,38 +0,06 +0,08 | 5 | 18 | Standard BR-G8S BR-G8M BR-G8 BR-G8A BRC-G8M BRC-G8 BRC-G8HP |
| GP8-Q-1/8" | GP8C-Q-1/8" | GP8K-Q-1/8" | GP8KC-Q-1/8" | 8 | 3,17 +0,07 +0,09 | 6 | 18 | |
| GP8-Q-5/32" | GP8C-Q-5/32" | GP8K-Q-5/32" | GP8KC-Q-5/32" | 8 | 3,97 +0,08 +0,10 | 8 | 18 | |
| GP8-Q-3/16" | GP8C-Q-3/16" | GP8K-Q-3/16" | GP8KC-Q-3/16" | 8 | 4,76 +0,08 +0,10 | 9 | 18 | |
| GP8-Q-7/32" | GP8C-Q-7/32" | GP8K-Q-7/32" | GP8KC-Q-7/32" | 8 | 5,55 +0,08 +0,10 | 11 | 18 | |
| GP8-Q-1/4" | GP8C-Q-1/4" | GP8K-Q-1/4" | GP8KC-Q-1/4" | 8 | 6,35 +0,08 +0,10 | 13 | 18 | |

In questi articoli possiamo eseguire i seguenti rivestimenti: **HDP RED, WONDER, TiN, INOX PLUS e ZIRINOS** > vedi pag. 18
 Available coatings for the up above mentioned items: **HDP RED, WONDER, TiN, INOX PLUS and ZIRINOS** > see page 18





NOVITA' NEW

**BROCCE GP8A - DIAMETRO "d" DEL GAMBO: 8 mm
MISURE IN POLLICI**

**GP8A BROACHES - 8 mm SHANK DIAMETER ("d")
SIZES IN INCHES**

**Per Brocciatori REGISTRABILI /
For ADJUSTABLE Broaching Heads
BR-G8A**

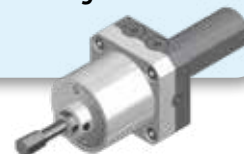

**Sezione ESAGONALE standard (E)
Standard HEXAGONAL section (E)**

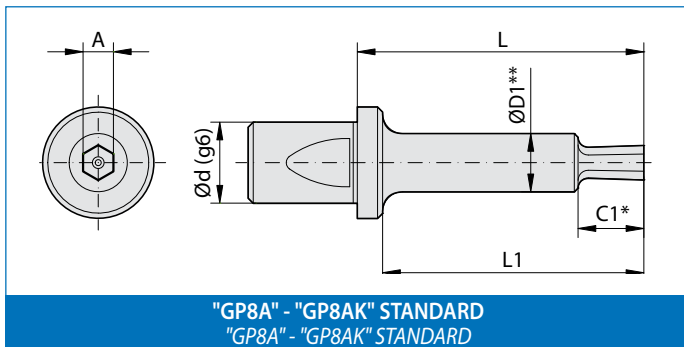

"GP8A" - "GP8AK" STANDARD
"GP8A" - "GP8AK" STANDARD

**Sezione QUADRA standard (Q)
Standard SQUARE section (Q)**

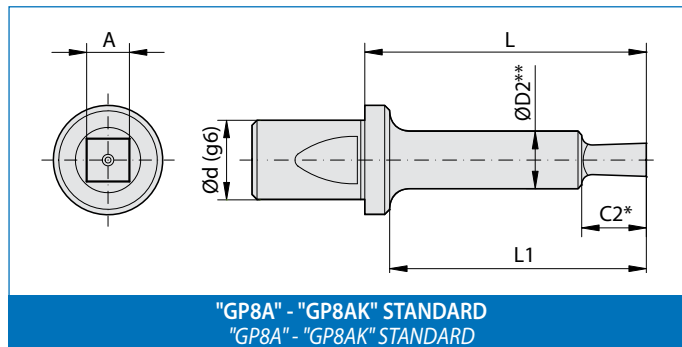

"GP8A" - "GP8AK" STANDARD
"GP8A" - "GP8AK" STANDARD

| ESAGONALE / HEXAGONAL | |
|---|--------------------------|
| ARTICOLO (materiale) ITEM (material) | |
| HSS | SINTERIZZATO SINTERED |
| Standard | Standard |
| GP8A-E-3/32" | GP8AK-E-3/32" |
| GP8A-E-1/8" | GP8AK-E-1/8" |
| GP8A-E-5/32" | GP8AK-E-5/32" |
| GP8A-E-3/16" | GP8AK-E-3/16" |
| GP8A-E-7/32" | GP8AK-E-7/32" |
| GP8A-E-1/4" | GP8AK-E-1/4" |

| QUADRA / SQUARE | |
|---|--------------------------|
| ARTICOLO (materiale) ITEM (material) | |
| HSS | SINTERIZZATO SINTERED |
| Standard | Standard |
| GP8A-Q-3/32" | GP8AK-Q-3/32" |
| GP8A-Q-1/8" | GP8AK-Q-1/8" |
| GP8A-Q-5/32" | GP8AK-Q-5/32" |
| GP8A-Q-3/16" | GP8AK-Q-3/16" |
| GP8A-Q-7/32" | GP8AK-Q-7/32" |
| / | / |

| DIMENSIONI - DIMENSIONS | | | | | | | | Utilizzo su Brocciatori/ Use on Broaching heads |
|-------------------------|-----------------|----|----|-----|-----|------|------|--|
| d | A | L1 | L | C1* | C2* | D1** | D2** | |
| 8 | 2,38 +0,06+0,08 | 26 | 30 | 7 | 7 | 6,5 | 6,5 | Standard BR-G8A |
| 8 | 3,17 +0,07+0,09 | 26 | 30 | 7 | 9 | 6,5 | 7,5 | |
| 8 | 3,97 +0,08+0,10 | 26 | 30 | 9 | 11 | 7,5 | 7,5 | |
| 8 | 4,76 +0,08+0,10 | 26 | 30 | 11 | 13 | 7,5 | 9,5 | |
| 8 | 5,55 +0,08+0,10 | 26 | 30 | 13 | 13 | 8,5 | 10,5 | |
| 8 | 6,35 +0,08+0,10 | 26 | 30 | 13 | / | 8,5 | / | |

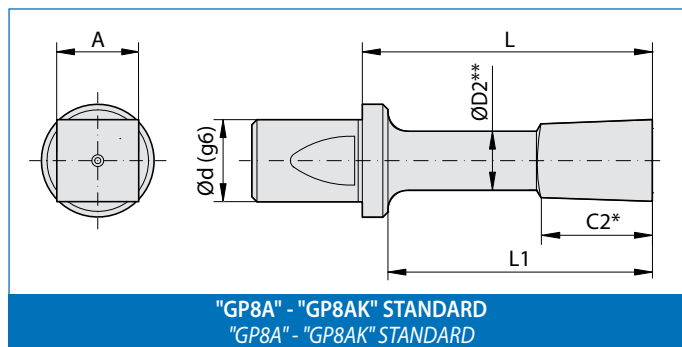

"GP8A" - "GP8AK" STANDARD
"GP8A" - "GP8AK" STANDARD

| | |
|-------------|--------------|
| GP8A-Q-1/4" | GP8AK-Q-1/4" |
| | |
| | |

| | | | | | | | | |
|---|-----------------|----|----|---|----|---|---|--------------------|
| 8 | 6,35 +0,08+0,10 | 26 | 30 | / | 13 | / | 6 | Standard BR-G8A |
| | | | | | | | | |
| | | | | | | | | |

C = Profondità utile di brocciatura / C = Depth of the shape
L1 = Profondità max. di lavoro / L1 = Maximum broaching depth

* le quote C1 e C2 possono essere maggiori rispetto alla tabella. In tal caso contattare la Brighetti Meccanica.
the dimensions C1 and C2 may be greater than in the table. In this case, contact Brighetti Meccanica.

** le quote D1 e D2 possono essere modificate a seconda della profondità di lavoro da realizzare. In tal caso contattare la Brighetti Meccanica.
the dimensions D1 and D2 can be modified depending on the working depth to be achieved. In this case, contact Brighetti Meccanica.

In questi articoli possiamo eseguire i seguenti rivestimenti: HDP RED, WONDER, TiN, INOX PLUS e ZIRINOS > vedi pag.18
Available coatings for the up above mentioned items: HDP RED, WONDER, TiN, INOX PLUS and ZIRINOS > see page 18





BROCCE GP12 E GP12C - DIAMETRO "d" DEL GAMBO: 12 mm - MISURE IN POLLICI GP12 E GP12C BROACHES - 12 mm SHANK DIAMETER ("d") - SIZES IN INCHES

Sezione ESAGONALE (E) / HEXAGONAL section (E)

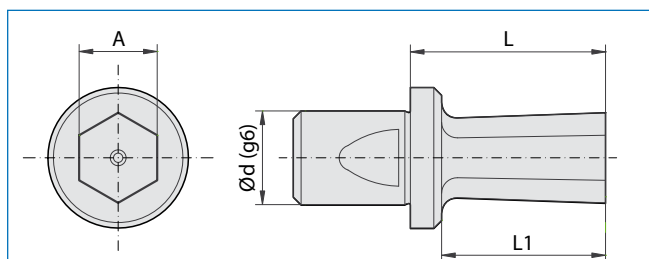

"GP12" - "GP12K" STANDARD
"GP12" - "GP12K" STANDARD

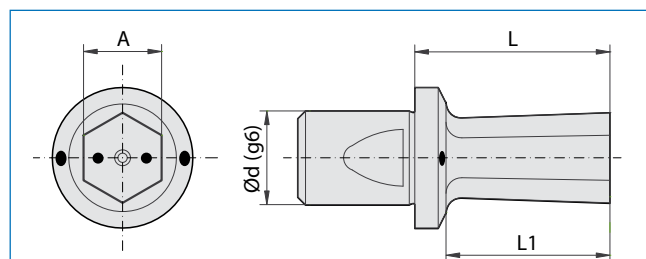

"GP12C" - "GP12KC" CON PASSAGGIO REFRIGERANTE INTERNO
"GP12C" - "GP12KC" WITH INTERNAL FLOW OF COOLANT

| ARTICOLO (materiale) - ITEM (material) | | | | DIMENSIONI - DIMENSIONS | | | | Utilizzo su Brocciatori/ Use on Broaching heads |
|--|---------------|-------------------------|----------------|-------------------------|-------------------|----|----|--|
| HSS | | SINTERIZZATO / SINTERED | | d | A | L1 | L | |
| Standard | Ref. / Cool. | Standard | Ref. / Cool. | | | | | |
| GP12-E-3/32" | / | GP12K-E-3/32" | / | 12 | 2,38 +0,06 +0,08 | 5 | 25 | Standard BR-G12B BR-G12 BR-G12A |
| GP12-E-1/8" | GP12C-E-1/8" | GP12K-E-1/8" | GP12KC-E-1/8" | 12 | 3,17 +0,07 +0,09 | 6 | 25 | |
| GP12-E-5/32" | GP12C-E-5/32" | GP12K-E-5/32" | GP12KC-E-5/32" | 12 | 3,97 +0,08 +0,10 | 8 | 25 | |
| GP12-E-3/16" | GP12C-E-3/16" | GP12K-E-3/16" | GP12KC-E-3/16" | 12 | 4,76 +0,08 +0,10 | 9 | 25 | |
| GP12-E-7/32" | GP12C-E-7/32" | GP12K-E-7/32" | GP12KC-E-7/32" | 12 | 5,55 +0,08 +0,10 | 11 | 25 | |
| GP12-E-1/4" | GP12C-E-1/4" | GP12K-E-1/4" | GP12KC-E-1/4" | 12 | 6,35 +0,08 +0,10 | 13 | 25 | |
| GP12-E-9/32" | GP12C-E-9/32" | GP12K-E-9/32" | GP12KC-E-9/32" | 12 | 7,14 +0,09 +0,11 | 16 | 25 | Refrig. / Cool. BRC-G12B BRC-G12 |
| GP12-E-5/16" | GP12C-E-5/16" | GP12K-E-5/16" | GP12KC-E-5/16" | 12 | 7,93 +0,09 +0,11 | 16 | 25 | |
| GP12-E-3/8" | GP12C-E-3/8" | GP12K-E-3/8" | GP12KC-E-3/8" | 12 | 9,52 +0,10 +0,12 | 18 | 25 | |
| GP12-E-7/16" | GP12C-E-7/16" | GP12K-E-7/16" | GP12KC-E-7/16" | 12 | 11,11 +0,11 +0,13 | 21 | 25 | |
| GP12-E-1/2" | GP12C-E-1/2" | GP12K-E-1/2" | GP12KC-E-1/2" | 12 | 12,70 +0,12 +0,14 | 21 | 25 | |
| GP12-E-9/16" | GP12C-E-9/16" | GP12K-E-9/16" | GP12KC-E-9/16" | 12 | 14,28 +0,12 +0,14 | 21 | 25 | |

Sezione QUADRA (Q) / SQUARE section (Q)

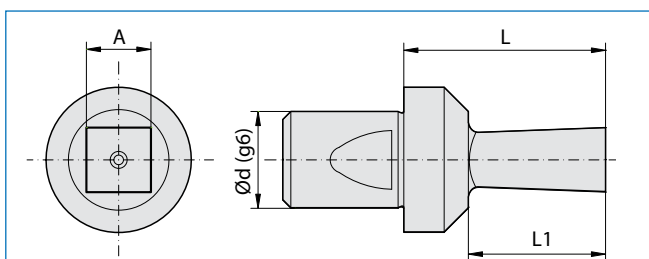

"GP12" - "GP12K" STANDARD
"GP12" - "GP12K" STANDARD

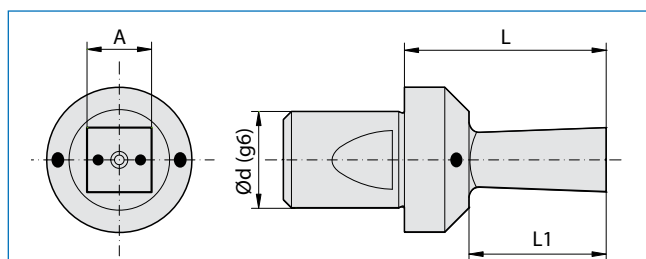

"GP12C" - "GP12KC" CON PASSAGGIO REFRIGERANTE INTERNO
"GP12C" - "GP12KC" WITH INTERNAL FLOW OF COOLANT

| ARTICOLO (materiale) - ITEM (material) | | | | DIMENSIONI - DIMENSIONS | | | | Utilizzo su Brocciatori/ Use on Broaching heads |
|--|---------------|-------------------------|----------------|-------------------------|-------------------|----|----|--|
| HSS | | SINTERIZZATO / SINTERED | | d | A | L1 | L | |
| Standard | Ref. / Cool. | Standard | Ref. / Cool. | | | | | |
| GP12-Q-3/32" | / | GP12K-Q-3/32" | / | 12 | 2,38 +0,06 +0,08 | 5 | 25 | Standard BR-G12B BR-G12 BR-G12A |
| GP12-Q-1/8" | GP12C-Q-1/8" | GP12K-Q-1/8" | GP12KC-Q-1/8" | 12 | 3,17 +0,07 +0,09 | 6 | 25 | |
| GP12-Q-5/32" | GP12C-Q-5/32" | GP12K-Q-5/32" | GP12KC-Q-5/32" | 12 | 3,97 +0,08 +0,10 | 8 | 25 | |
| GP12-Q-3/16" | GP12C-Q-3/16" | GP12K-Q-3/16" | GP12KC-Q-3/16" | 12 | 4,76 +0,08 +0,10 | 9 | 25 | |
| GP12-Q-7/32" | GP12C-Q-7/32" | GP12K-Q-7/32" | GP12KC-Q-7/32" | 12 | 5,55 +0,08 +0,10 | 11 | 25 | |
| GP12-Q-1/4" | GP12C-Q-1/4" | GP12K-Q-1/4" | GP12KC-Q-1/4" | 12 | 6,35 +0,08 +0,10 | 15 | 25 | |
| GP12-Q-9/32" | GP12C-Q-9/32" | GP12K-Q-9/32" | GP12KC-Q-9/32" | 12 | 7,14 +0,09 +0,11 | 16 | 25 | Refrig. / Cool. BRC-G12B BRC-G12 |
| GP12-Q-5/16" | GP12C-Q-5/16" | GP12K-Q-5/16" | GP12KC-Q-5/16" | 12 | 7,93 +0,09 +0,11 | 16 | 25 | |
| GP12-Q-3/8" | GP12C-Q-3/8" | GP12K-Q-3/8" | GP12KC-Q-3/8" | 12 | 9,52 +0,10 +0,12 | 18 | 25 | |
| GP12-Q-7/16" | GP12C-Q-7/16" | GP12K-Q-7/16" | GP12KC-Q-7/16" | 12 | 11,11 +0,11 +0,13 | 21 | 25 | |
| GP12-Q-1/2" | GP12C-Q-1/2" | GP12K-Q-1/2" | GP12KC-Q-1/2" | 12 | 12,70 +0,12 +0,14 | 21 | 25 | |

In questi articoli possiamo eseguire i seguenti rivestimenti: HDP RED, WONDER, TiN, INOX PLUS e ZIRINOS > vedi pag.18
Available coatings for the up above mentioned items: HDP RED, WONDER, TiN, INOX PLUS and ZIRINOS > see page 18





**BROCCHE GP12A - DIAMETRO "d" DEL GAMBO: 12 mm
MISURE IN POLLICI**

**GP12A BROACHES - 12 mm SHANK DIAMETER ("d")
SIZES IN INCHES**

**Per Brocciatori REGISTRABILI /
For ADJUSTABLE Broaching Heads
BR-G12A**



**Sezione ESAGONALE standard (E)
Standard HEXAGONAL section (E)**

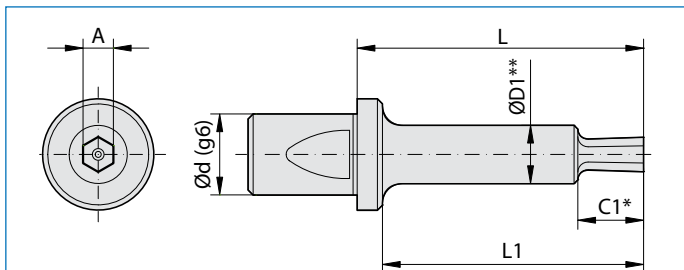

"GP12A" - "GP12AK" STANDARD
"GP12A" - "GP12AK" STANDARD

**Sezione QUADRA standard (Q)
Standard SQUARE section (Q)**

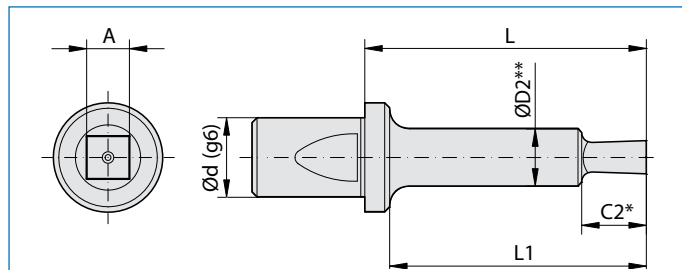

"GP12A" - "GP12AK" STANDARD
"GP12A" - "GP12AK" STANDARD

| ESAGONALE / HEXAGONAL | |
|---|--------------------------|
| ARTICOLO (materiale) ITEM (material) | |
| HSS | SINTERIZZATO SINTERED |
| Standard | Standard |
| GP12A-E-1/8" | GP12AK-E-1/8" |
| GP12A-E-5/32" | GP12AK-E-5/32" |
| GP12A-E-3/16" | GP12AK-E-3/16" |
| GP12A-E-7/32" | GP12AK-E-7/32" |
| GP12A-E-1/4" | GP12AK-E-1/4" |

| QUADRA / SQUARE | |
|---|--------------------------|
| ARTICOLO (materiale) ITEM (material) | |
| HSS | SINTERIZZATO SINTERED |
| Standard | Standard |
| GP12A-Q-1/8" | GP12AK-Q-1/8" |
| GP12A-Q-5/32" | GP12AK-Q-5/32" |
| GP12A-Q-3/16" | GP12AK-Q-3/16" |
| GP12A-Q-7/32" | GP12AK-Q-7/32" |
| / | / |

| DIMENSIONI - DIMENSIONS | | | | | | | | | Utilizzo su Brocciatori/ Use on Broaching heads |
|-------------------------|-----------------|----|----|-----|-----|------|------|---------------------|--|
| d | A | L1 | L | C1* | C2* | D1** | D2** | | |
| 12 | 3,17 +0,07+0,09 | 55 | 60 | 9 | 9 | 10 | 10 | Standard BR-G12A | |
| 12 | 3,97 +0,08+0,10 | 55 | 60 | 9 | 9 | 10 | 10 | | |
| 12 | 4,76 +0,08+0,10 | 55 | 60 | 11 | 11 | 10 | 10 | | |
| 12 | 5,55 +0,08+0,10 | 55 | 60 | 11 | 11 | 10 | 10 | | |
| 12 | 6,35 +0,08+0,10 | 55 | 60 | 17 | / | 10 | / | | |
| 12 | 6,35 +0,08+0,10 | 55 | 60 | 17 | / | 10 | / | | |

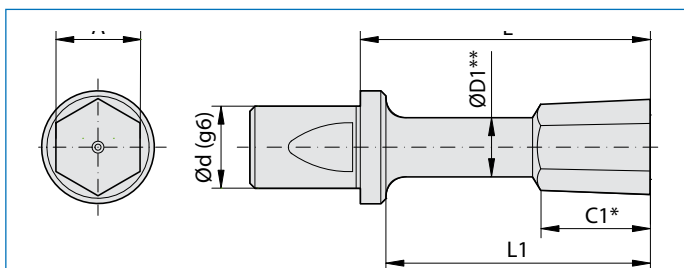

"GP12A" - "GP12AK" STANDARD
"GP12A" - "GP12AK" STANDARD

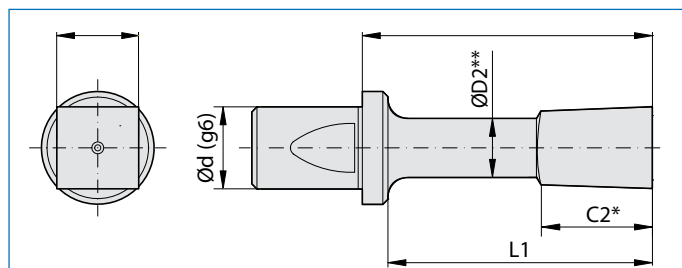

"GP12A" - "GP12AK" STANDARD
"GP12A" - "GP12AK" STANDARD

| | |
|---------------|----------------|
| / | / |
| GP12A-E-9/32" | GP12AK-E-9/32" |
| GP12A-E-5/16" | GP12AK-E-5/16" |
| GP12A-E-3/8" | GP12AK-E-3/8" |
| GP12A-E-1/2" | GP12AK-E-1/2" |

| | |
|---------------|----------------|
| GP12A-Q-1/4" | GP12AK-Q-1/4" |
| GP12A-Q-9/32" | GP12AK-Q-9/32" |
| GP12A-Q-5/16" | GP12AK-Q-5/16" |
| GP12A-Q-3/8" | GP12AK-Q-3/8" |
| GP12A-Q-1/2" | GP12AK-Q-1/2" |

| | | | | | | | | |
|----|------------------|----|----|----|----|-----|---|---------------------|
| 12 | 6,35 +0,08+0,10 | 55 | 60 | / | 19 | / | 5 | Standard BR-G12A |
| 12 | 7,14 +0,09+0,11 | 55 | 60 | 17 | 19 | 6,7 | 5 | |
| 12 | 7,93 +0,09+0,11 | 55 | 60 | 17 | 19 | 6,7 | 5 | |
| 12 | 9,52 +0,10+0,12 | 55 | 60 | 21 | 21 | 7,7 | 6 | |
| 12 | 12,70 +0,12+0,14 | 55 | 60 | 21 | 21 | 11 | 7 | |
| 12 | 12,70 +0,12+0,14 | 55 | 60 | 21 | 21 | 11 | 7 | |

C = Profondità utile di brocciatura / C = Depth of the shape
L1 = Profondità max. di lavoro / L1 = Maximum broaching depth

* le quote C1 e C2 possono essere maggiori rispetto alla tabella. In tal caso contattare la Brighetti Meccanica.
the dimensions C1 and C2 may be greater than in the table. In this case, contact Brighetti Meccanica.

** le quote D1 e D2 possono essere modificate a seconda della profondità di lavoro da realizzare. In tal caso contattare la Brighetti Meccanica.
the dimensions D1 and D2 can be modified depending on the working depth to be achieved. In this case, contact Brighetti Meccanica.

In questi articoli possiamo eseguire i seguenti rivestimenti: **HDP RED, WONDER, TiN, INOX PLUS e ZIRINOS** > vedi pag.18
Available coatings for the up above mentioned items: **HDP RED, WONDER, TiN, INOX PLUS and ZIRINOS** > see page 18





BROCCE GP16 - DIAMETRO "d" DEL GAMBO: 16 mm - MISURE IN POLLICI

GP16 BROACHES - 16 mm SHANK DIAMETER ("d") - SIZES IN INCHES

Sezione ESAGONALE standard (E)

Standard HEXAGONAL section (E)

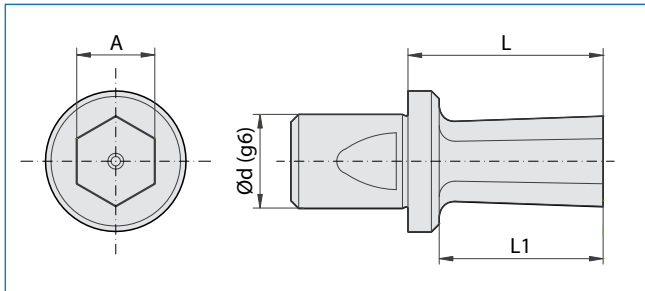

"GP16" - "GP16K" STANDARD
"GP16" - "GP16K" STANDARD

Sezione QUADRA standard (Q)

Standard SQUARE section (Q)

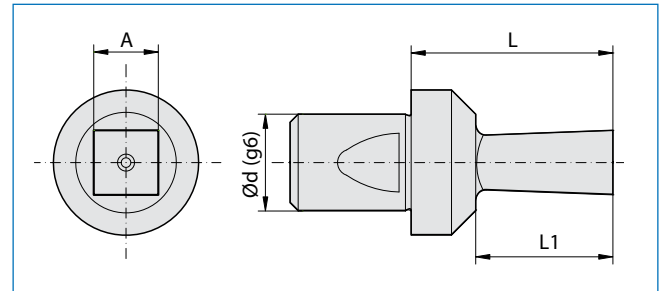

"GP16" - "GP16K" STANDARD
"GP16" - "GP16K" STANDARD

| ESAGONALE / HEXAGONAL | |
|---|--------------------------|
| ARTICOLO (materiale) ITEM (material) | |
| HSS | SINTERIZZATO SINTERED |
| Standard | Standard |
| GP16-E-3/32" | GP16K-E-3/32" |
| GP16-E-1/8" | GP16K-E-1/8" |
| GP16-E-5/32" | GP16K-E-5/32" |
| GP16-E-3/16" | GP16K-E-3/16" |
| GP16-E-7/32" | GP16K-E-7/32" |
| GP16-E-1/4" | GP16K-E-1/4" |
| GP16-E-9/32" | GP16K-E-9/32" |
| GP16-E-5/16" | GP16K-E-5/16" |
| GP16-E-3/8" | GP16K-E-3/8" |
| GP16-E-7/16" | GP16K-E-7/16" |
| GP16-E-1/2" | GP16K-E-1/2" |
| GP16-E-9/16" | GP16K-E-9/16" |
| GP16-E-5/8" | GP16K-E-5/8" |
| GP16-E-3/4" | GP16K-E-3/4" |
| GP16-E-7/8" | GP16K-E-7/8" |
| GP16-E-1" | GP16K-E-1" |

| QUADRA / SQUARE | |
|---|--------------------------|
| ARTICOLO (materiale) ITEM (material) | |
| HSS | SINTERIZZATO SINTERED |
| Standard | Standard |
| GP16-Q-3/32" | GP16K-Q-3/32" |
| GP16-Q-1/8" | GP16K-Q-1/8" |
| GP16-Q-5/32" | GP16K-Q-5/32" |
| GP16-Q-3/16" | GP16K-Q-3/16" |
| GP16-Q-7/32" | GP16K-Q-7/32" |
| GP16-Q-1/4" | GP16K-Q-1/4" |
| GP16-Q-9/32" | GP16K-Q-9/32" |
| GP16-Q-5/16" | GP16K-Q-5/16" |
| GP16-Q-3/8" | GP16K-Q-3/8" |
| GP16-Q-7/16" | GP16K-Q-7/16" |
| GP16-Q-1/2" | GP16K-Q-1/2" |
| GP16-Q-9/16" | GP16K-Q-9/16" |
| GP16-Q-5/8" | GP16K-Q-5/8" |
| / | / |

| DIMENSIONI - DIMENSIONS | | | | | Utilizzo su Brocciatori/ Use on Broaching heads |
|-------------------------|-------------------|----|----|--------------------|--|
| d | A | L1 | L | | |
| 16 | 2,38 +0,06 +0,08 | 5 | 25 | Standard BR-G16 | |
| 16 | 3,17 +0,07 +0,09 | 6 | 25 | | |
| 16 | 3,97 +0,08 +0,10 | 8 | 25 | | |
| 16 | 4,76 +0,08 +0,10 | 9 | 25 | | |
| 16 | 5,55 +0,08 +0,10 | 11 | 25 | | |
| 16 | 6,35 +0,08 +0,10 | 15 | 25 | | |
| 16 | 7,14 +0,09 +0,11 | 16 | 25 | | |
| 16 | 7,93 +0,09 +0,11 | 16 | 25 | | |
| 16 | 9,52 +0,10 +0,12 | 18 | 25 | | |
| 16 | 11,11 +0,11 +0,13 | 21 | 25 | | |
| 16 | 12,70 +0,12 +0,14 | 21 | 25 | | |
| 16 | 14,28 +0,12 +0,14 | 21 | 25 | | |
| 16 | 15,87 +0,13 +0,15 | 21 | 25 | | |
| 16 | 19,05 +0,17 +0,19 | 21 | 25 | | |
| 16 | 22,22 +0,21 +0,23 | 21 | 25 | | |
| 16 | 25,40 +0,22 +0,24 | 21 | 25 | | |

In questi articoli possiamo eseguire i seguenti rivestimenti: **HDP RED, WONDER, TiN, INOX PLUS e ZIRINOS** > vedi pag.18
Available coatings for the up above mentioned items: **HDP RED, WONDER, TiN, INOX PLUS and ZIRINOS** > see page 18





BROCCE GP16M E GP16MC - DIAMETRO "d" DEL GAMBO: 16 mm - MISURE IN POLLICI GP16M AND GP16MC BROACHES - 16 mm SHANK DIAMETER ("d") - SIZES IN INCHES

Sezione ESAGONALE (E) / HEXAGONAL section (E)

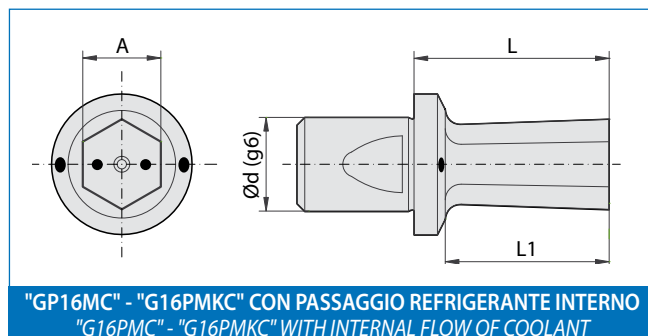
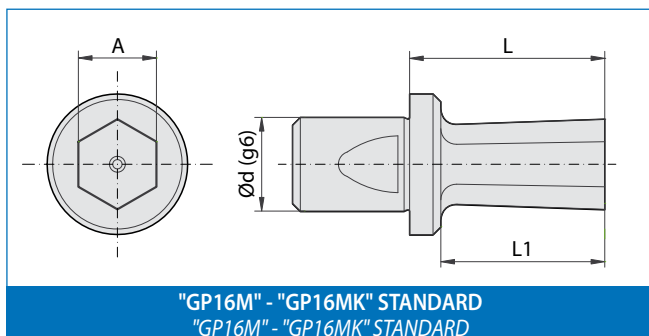

| ARTICOLO (materiale) - ITEM (material) | | | | DIMENSIONI - DIMENSIONS | | | | Utilizzo su Brocciatori/ Use on Broaching heads |
|--|----------------|-------------------------|-----------------|-------------------------|-------------------|----|----|--|
| HSS | | SINTERIZZATO / SINTERED | | d | A | L1 | L | |
| Standard | Ref. / Cool. | Standard | Ref. / Cool. | | | | | |
| GP16M-E-1/4" | GP16MC-E-1/4" | GP16MK-E-1/4" | GP16MKC-E-1/4" | 16 | 6,35 +0,08 +0,10 | 15 | 35 | Standard BR-G16M |
| GP16M-E-9/32" | GP16MC-E-9/32" | GP16MK-E-9/32" | GP16MKC-E-9/32" | 16 | 7,14 +0,09 +0,11 | 16 | 35 | |
| GP16M-E-5/16" | GP16MC-E-5/16" | GP16MK-E-5/16" | GP16MKC-E-5/16" | 16 | 7,93 +0,09 +0,11 | 16 | 35 | |
| GP16M-E-3/8" | GP16MC-E-3/8" | GP16MK-E-3/8" | GP16MKC-E-3/8" | 16 | 9,52 +0,10 +0,12 | 18 | 35 | |
| GP16M-E-7/16" | GP16MC-E-7/16" | GP16MK-E-7/16" | GP16MKC-E-7/16" | 16 | 11,11 +0,11 +0,13 | 31 | 35 | |
| GP16M-E-1/2" | GP16MC-E-1/2" | GP16MK-E-1/2" | GP16MKC-E-1/2" | 16 | 12,70 +0,12 +0,14 | 31 | 35 | |
| GP16M-E-9/16" | GP16MC-E-9/16" | GP16MK-E-9/16" | GP16MKC-E-9/16" | 16 | 14,28 +0,12 +0,14 | 31 | 35 | Refrig. / Cool. BRC-G16M |
| GP16M-E-5/8" | GP16MC-E-5/8" | GP16MK-E-5/8" | GP16MKC-E-5/8" | 16 | 15,87 +0,13 +0,15 | 31 | 35 | |
| GP16M-E-3/4" | GP16MC-E-3/4" | GP16MK-E-3/4" | GP16MKC-E-3/4" | 16 | 19,05 +0,17 +0,19 | 31 | 35 | |
| GP16M-E-7/8" | GP16MC-E-7/8" | GP16MK-E-7/8" | GP16MKC-E-7/8" | 16 | 22,22 +0,21 +0,23 | 31 | 35 | |
| GP16M-E-1" | GP16MC-E-1" | GP16MK-E-1" | GP16MKC-E-1" | 16 | 25,40 +0,22 +0,24 | 31 | 35 | |

Sezione QUADRA (Q) / SQUARE section (Q)

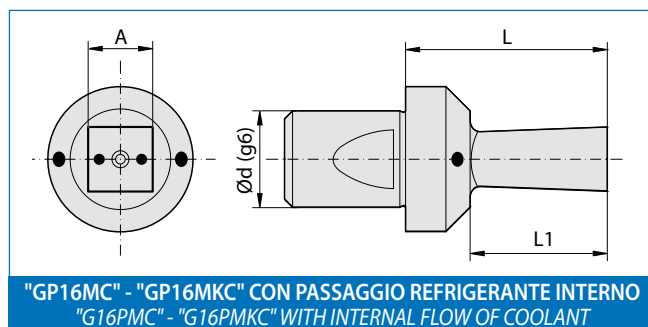
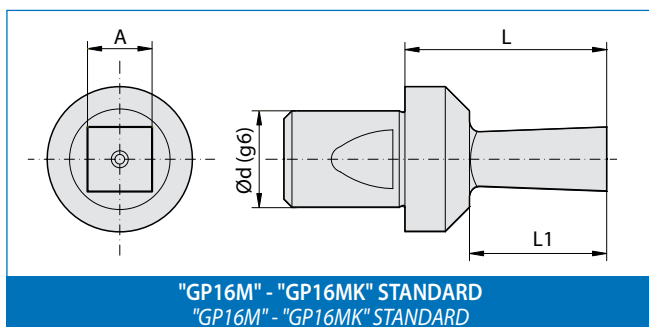

| ARTICOLO (materiale) - ITEM (material) | | | | DIMENSIONI - DIMENSIONS | | | | Utilizzo su Brocciatori/ Use on Broaching heads |
|--|----------------|-------------------------|-----------------|-------------------------|-------------------|----|----|--|
| HSS | | SINTERIZZATO / SINTERED | | d | A | L1 | L | |
| Standard | Ref. / Cool. | Standard | Ref. / Cool. | | | | | |
| GP16M-Q-1/4" | GP16MC-Q-1/4" | GP16MK-Q-1/4" | GP16MKC-Q-1/4" | 16 | 6,35 +0,08 +0,10 | 15 | 35 | Standard BR-G16M |
| GP16M-Q-9/32" | GP16MC-Q-9/32" | GP16MK-Q-9/32" | GP16MKC-Q-9/32" | 16 | 7,14 +0,09 +0,11 | 16 | 35 | |
| GP16M-Q-5/16" | GP16MC-Q-5/16" | GP16MK-Q-5/16" | GP16MKC-Q-5/16" | 16 | 7,93 +0,09 +0,11 | 16 | 35 | |
| GP16M-Q-3/8" | GP16MC-Q-3/8" | GP16MK-Q-3/8" | GP16MKC-Q-3/8" | 16 | 9,52 +0,10 +0,12 | 18 | 35 | |
| GP16M-Q-7/16" | GP16MC-Q-7/16" | GP16MK-Q-7/16" | GP16MKC-Q-7/16" | 16 | 11,11 +0,11 +0,13 | 31 | 35 | |
| GP16M-Q-1/2" | GP16MC-Q-1/2" | GP16MK-Q-1/2" | GP16MKC-Q-1/2" | 16 | 12,70 +0,12 +0,14 | 31 | 35 | |
| GP16M-Q-9/16" | GP16MC-Q-9/16" | GP16MK-Q-9/16" | GP16MKC-Q-9/16" | 16 | 14,28 +0,12 +0,14 | 31 | 35 | Refrig. / Cool. BRC-G16M |
| GP16M-Q-5/8" | GP16MC-Q-5/8" | GP16MK-Q-5/8" | GP16MKC-Q-5/8" | 16 | 15,87 +0,13 +0,15 | 31 | 35 | |
| GP16M-Q-3/4" | GP16MC-Q-3/4" | GP16MK-Q-3/4" | GP16MKC-Q-3/4" | 16 | 19,05 +0,17 +0,19 | 31 | 35 | |

In questi articoli possiamo eseguire i seguenti rivestimenti: **HDP RED, WONDER, TiN, INOX PLUS e ZIRINOS** > vedi pag.18
Available coatings for the up above mentioned items: **HDP RED, WONDER, TiN, INOX PLUS and ZIRINOS** > see page 18





BROCCHE GP16L E GP16LC - DIAMETRO "d" DEL GAMBO: 16 mm - MISURE IN POLLICI
GP16L AND GP16LC BROACHES - 16 mm SHANK DIAMETER ("d") - SIZES IN INCHES

Sezione ESAGONALE (E)
HEXAGONAL section (E)

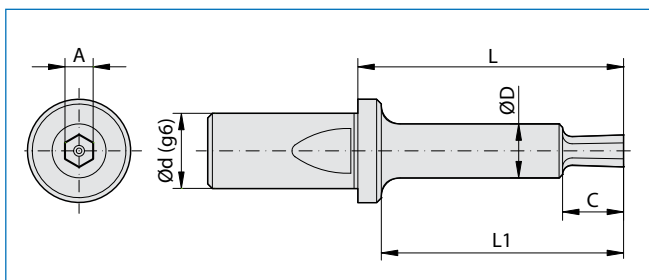

"GP16L" - "GP16LK" STANDARD
 "GP16L" - "GP16LK" STANDARD

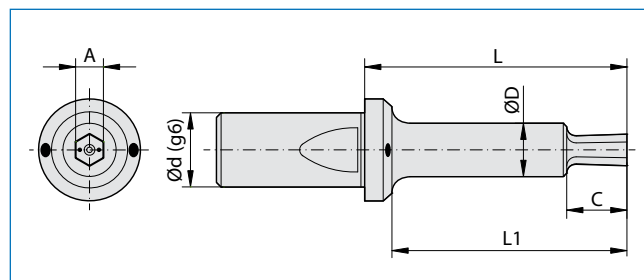

"GP16LC" - "GP16LKC" CON PASSAGGIO REFRIGERANTE INTERNO
 "GP16LC" - "GP16LKC" WITH INTERNAL FLOW OF COOLANT

| ARTICOLO (materiale) - ITEM (material) | | | | DIMENSIONI - DIMENSIONS | | | | | | Utilizzo su Broccatori/ Use on Broaching heads |
|--|----------------|-------------------------|-----------------|-------------------------|------------------|----|----|----|---|--|
| HSS | | SINTERIZZATO / SINTERED | | d | A | L1 | L | C | D | |
| Standard | Ref. / Cool. | Standard | Ref. / Cool. | 16 | 6,35 +0,08 +0,10 | 41 | 45 | 13 | 9 | Standard BR-G16L Refrig. / Cool. BRC-G16L |
| GP16L-E-1/4" | GP16LC-E-1/4" | GP16LK-E-1/4" | GP16LKC-E-1/4" | 16 | 7,14 +0,09 +0,11 | 41 | 45 | 15 | 9 | |
| GP16L-E-9/32" | GP16LC-E-9/32" | GP16LK-E-9/32" | GP16LKC-E-9/32" | 16 | 7,93 +0,09 +0,11 | 41 | 45 | 16 | 9 | |
| GP16L-E-5/16" | GP16LC-E-5/16" | GP16LK-E-5/16" | GP16LKC-E-5/16" | 16 | 9,52 +0,10 +0,12 | 41 | 45 | 17 | 9 | |

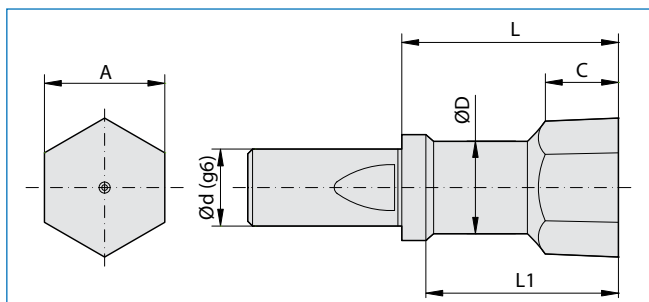

"G16L" - "G16LK" STANDARD
 "G16L" - "G16LK" STANDARD

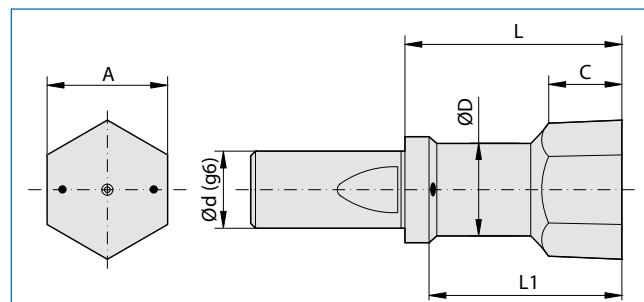

"G16LC" - "G16LKC" CON PASSAGGIO REFRIGERANTE INTERNO
 "G16LC" - "G16LKC" WITH INTERNAL FLOW OF COOLANT

| | | | | | | | | | | |
|---------------|----------------|----------------|-----------------|----|-------------------|----|----|----|------|--|
| GP16L-E-7/16" | GP16LC-E-7/16" | GP16LK-E-7/16" | GP16LKC-E-7/16" | 16 | 11,11 +0,11 +0,13 | 41 | 45 | 17 | 9 | Standard BR-G16L Refrig. / Cool. BRC-G16L |
| GP16L-E-1/2" | GP16LC-E-1/2" | GP16LK-E-1/2" | GP16LKC-E-1/2" | 16 | 12,70 +0,12 +0,14 | 41 | 45 | 17 | 10,5 | |
| GP16L-E-9/16" | GP16LC-E-9/16" | GP16LK-E-9/16" | GP16LKC-E-9/16" | 16 | 14,28 +0,12 +0,14 | 41 | 45 | 17 | 12,5 | |
| GP16L-E-5/8" | GP16LC-E-5/8" | GP16LK-E-5/8" | GP16LKC-E-5/8" | 16 | 15,87 +0,13 +0,15 | 41 | 45 | 17 | 13,5 | |
| GP16L-E-3/4" | GP16LC-E-3/4" | GP16LK-E-3/4" | GP16LKC-E-3/4" | 16 | 19,05 +0,17 +0,19 | 41 | 45 | 17 | 16,5 | |
| GP16L-E-7/8" | GP16LC-E-7/8" | GP16LK-E-7/8" | GP16LKC-E-7/8" | 16 | 22,22 +0,21 +0,23 | 41 | 45 | 17 | 19,5 | |
| GP16L-E-1" | GP16LC-E-1" | GP16LK-E-1" | GP16LKC-E-1" | 16 | 25,40 +0,22 +0,24 | 41 | 45 | 17 | 21,5 | |

C = Profondità utile di brocciatura - L1 = Profondità max. di lavoro / C = Depth of the shape - L1 = Maximum broaching depth

In questi articoli possiamo eseguire i seguenti rivestimenti: **HDP RED, WONDER, TiN, INOX PLUS e ZIRINOS** > vedi pag.18
 Available coatings for the up above mentioned items: **HDP RED, WONDER, TiN, INOX PLUS and ZIRINOS** > see page 18





BROCCE GP16L E GP16LC - DIAMETRO "d" DEL GAMBO: 16 mm - MISURE IN POLLICI GP16L AND GP16LC BROACHES - 16 mm SHANK DIAMETER ("d") - SIZES IN INCHES

Sezione QUADRA (Q) SQUARE section (Q)

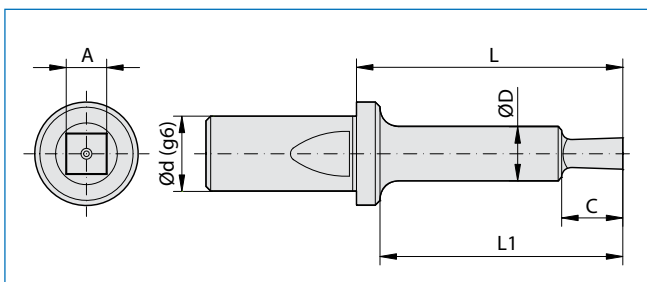

"GP16L" - "GP16LK" STANDARD
"GP16L" - "GP16LK" STANDARD

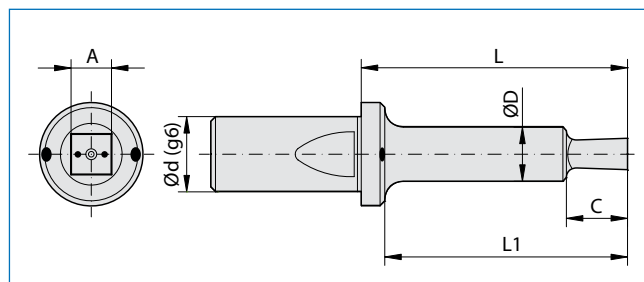

"GP16LC" - "GP16LKC" CON PASSAGGIO REFRIGERANTE INTERNO
"GP16LC" - "GP16LKC" WITH INTERNAL FLOW OF COOLANT

| ARTICOLO (materiale) - ITEM (material) | | | | DIMENSIONI - DIMENSIONS | | | | | | Utilizzo su Brocciatori/ Use on Broaching heads |
|--|---------------------------------------|-----------------------------------|---------------------------------------|-------------------------|------------------|----|----|----|---|--|
| HSS | | SINTERIZZATO / SINTERED | | d | A | L1 | L | C | D | |
| Standard <input type="checkbox"/> | Ref. / Cool. <input type="checkbox"/> | Standard <input type="checkbox"/> | Ref. / Cool. <input type="checkbox"/> | | | | | | | Standard BR-G16L Refrig. / Cool. BRC-G16L |
| GP16L-Q-1/4" | / | GP16LK-Q-1/4" | / | 16 | 6,35 +0,08 +0,10 | 41 | 45 | 13 | 9 | |
| GP16L-Q-9/32" | | GP16LK-Q-9/32" | | 16 | 7,14 +0,09 +0,11 | 41 | 45 | 15 | 9 | |
| GP16L-Q-5/16" | | GP16LK-Q-5/16" | | 16 | 7,93 +0,09 +0,11 | 41 | 45 | 16 | 9 | |
| GP16L-Q-3/8" | GP16LC-Q-3/8" | GP16LK-Q-3/8" | GP16LKC-Q-3/8" | 16 | 9,52 +0,10 +0,12 | 41 | 45 | 17 | 9 | |

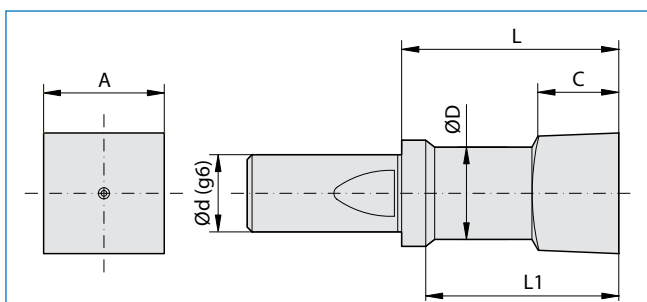

"G16L" - "G16LK" STANDARD
"G16L" - "G16LK" STANDARD

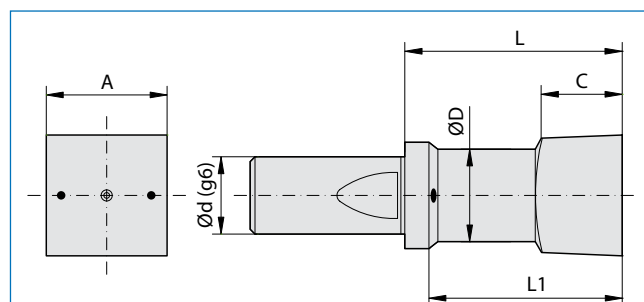

"G16LC" - "G16LKC" CON PASSAGGIO REFRIGERANTE INTERNO
"G16LC" - "G16LKC" WITH INTERNAL FLOW OF COOLANT

| | | | | | | | | | | |
|---------------|----------------|----------------|-----------------|----|-------------------|----|----|----|------|--|
| GP16L-Q-7/16" | GP16LC-Q-7/16" | GP16LK-Q-7/16" | GP16LKC-Q-7/16" | 16 | 11,11 +0,11 +0,13 | 41 | 45 | 17 | 9 | Standard BR-G16L Refrig. / Cool. BRC-G16L |
| GP16L-Q-1/2" | GP16LC-Q-1/2" | GP16LK-Q-1/2" | GP16LKC-Q-1/2" | 16 | 12,70 +0,12 +0,14 | 41 | 45 | 17 | 10,5 | |
| GP16L-Q-9/16" | GP16LC-Q-9/16" | GP16LK-Q-9/16" | GP16LKC-Q-9/16" | 16 | 14,28 +0,12 +0,14 | 41 | 45 | 17 | 12,5 | |
| GP16L-Q-5/8" | GP16LC-Q-5/8" | GP16LK-Q-5/8" | GP16LKC-Q-5/8" | 16 | 15,87 +0,13 +0,15 | 41 | 45 | 17 | 13,5 | |
| GP16L-Q-3/4" | GP16LC-Q-3/4" | GP16LK-Q-3/4" | GP16LKC-Q-3/4" | 16 | 19,05 +0,17 +0,19 | 41 | 45 | 17 | 16,5 | |
| GP16L-Q-7/8" | GP16LC-Q-7/8" | GP16LK-Q-7/8" | GP16LKC-Q-7/8" | 16 | 22,22 +0,21 +0,23 | 41 | 45 | 17 | 19,5 | |
| GP16L-Q-1" | GP16LC-Q-1" | GP16LK-Q-1" | GP16LKC-Q-1" | 16 | 25,40 +0,22 +0,24 | 41 | 45 | 17 | 21,5 | |

C = Profondità utile di brocciatura - L1 = Profondità max. di lavoro / C = Depth of the shape - L1 = Maximum broaching depth

In questi articoli possiamo eseguire i seguenti rivestimenti: HDP RED, WONDER, TiN, INOX PLUS e ZIRINOS > vedi pag.18
Available coatings for the up above mentioned items: HDP RED, WONDER, TiN, INOX PLUS and ZIRINOS > see page 18





Brocche Standard e con passaggio refrigerante per chiavi TORX® Standard Broaches and with internal flow of coolant for TORX® wrenches

per Brocciatori Standard serie "BR"
for "BR" Standard Broaching Heads series



I L'originale disegno delle cave per chiavi TORX® consente, in dimensioni contenute, di esercitare una coppia di serraggio molto elevata senza compromettere l'integrità della cava.

GB The original design of the holes for TORX® wrenches makes it possible to exert a very high torque, despite the limited dimensions, without damaging the hole.

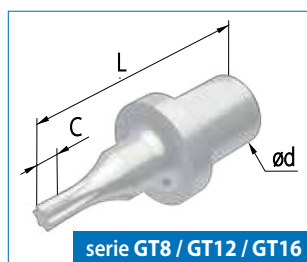
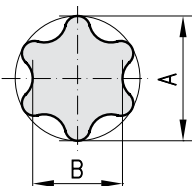

per Brocciatori serie "BRC"
for Broaching Heads "BRC" series



I Brocche per realizzazione di cave per chiavi TORX® per utilizzo su brocciatori serie "BRC" con passaggio refrigerante interno per poter avere una maggiore durata della broccia, una minore rugosità e poter lavorare materiali molto tenaci.

GB Broaches for TORX profiles suitable for broaching heads BRC series with internal flow of coolant. The flow of coolant increases the broach productivity, assures a minor roughness on the work-piece and helps to machine harder materials.

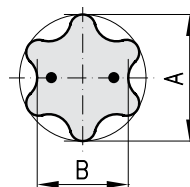

per brocciatori serie
for broaching heads

BR-G5

ød = 5

per brocciatori serie
for broaching heads

**BR-G8S / BR-G8M / BR-G8 / BR-G8A
BRC-G8M / BRC-G8 / BRC-G8HP**

ød = 8 / L = 18

| A | B | C | H max (*) | TORX® | ARTICOLO (materiale) ITEM (material) | | ARTICOLO (materiale) ITEM (material) | | | |
|-------|-------|-----|--------------|-------|---|-----------|---|--------------|-------------------------|--------------|
| | | | | | HSS | | HSS | | SINTERIZZATO / SINTERED | |
| | | | | | Standard | SINTERIZ. | Standard | Ref. / Cool. | Standard | Ref. / Cool. |
| 1,214 | 0,884 | 1,2 | 0,40 | 3 | GT5-T3 | GT5K-T3 | GT8-T3 | / | GT8K-T3 | / |
| 1,374 | 0,996 | 1,2 | 0,50 | 4 | GT5-T4 | GT5K-T4 | GT8-T4 | | GT8K-T4 | |
| 1,499 | 1,097 | 1,5 | 1,00 | 5 | GT5-T5 | GT5K-T5 | GT8-T5 | | GT8K-T5 | |
| 1,778 | 1,293 | 1,7 | 1,20 | 6 | GT5-T6 | GT5K-T6 | GT8-T6 | | GT8K-T6 | |
| 2,095 | 1,521 | 1,7 | 1,50 | 7 | GT5-T7 | GT5K-T7 | GT8-T7 | | GT8K-T7 | |
| 2,418 | 1,756 | 2,0 | 1,70 | 8 | GT5-T8 | GT5K-T8 | GT8-T8 | GT8C-T8 | GT8K-T8 | GT8KC-T8 |
| 2,603 | 1,889 | 2,0 | 1,70 | 9 | GT5-T9 | GT5K-T9 | GT8-T9 | GT8C-T9 | GT8K-T9 | GT8KC-T9 |
| 2,844 | 2,057 | 2,0 | 2,00 | 10 | GT5-T10 | GT5K-T10 | GT8-T10 | GT8C-T10 | GT8K-T10 | GT8KC-T10 |
| 3,378 | 2,438 | 3,0 | 3,00 | 15 | GT5-T15 | GT5K-T15 | GT8-T15 | GT8C-T15 | GT8K-T15 | GT8KC-T15 |
| 3,962 | 2,857 | 3,5 | 3,00 | 20 | GT5-T20 | GT5K-T20 | GT8-T20 | GT8C-T20 | GT8K-T20 | GT8KC-T20 |
| 4,559 | 3,276 | 4,0 | 3,50 | 25 | GT5-T25 | GT5K-T25 | GT8-T25 | GT8C-T25 | GT8K-T25 | GT8KC-T25 |
| 5,118 | 3,672 | 4,0 | 3,50 | 27 | | | GT8-T27 | GT8C-T27 | GT8K-T27 | GT8KC-T27 |
| 5,651 | 4,064 | 4,5 | 3,50 | 30 | / | / | GT8-T30 | GT8C-T30 | GT8K-T30 | GT8KC-T30 |
| 6,807 | 4,889 | 5,0 | 4,00 | 40 | | | GT8-T40 | GT8C-T40 | GT8K-T40 | GT8KC-T40 |

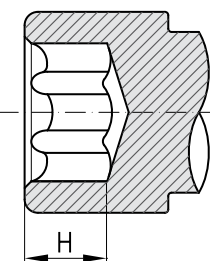
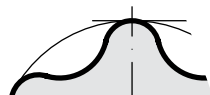



| | | | | | per broccatori serie for broaching heads BR-G12 / BR-G12B / BR-G12A / BRC-G12 / BRC-G12B | | | | per broccatori serie for broaching heads BR-G16 | |
|--------|--------|-----|--------------|-------|---|--------------|-------------------------|--------------|--|-----------|
| | | | | | $\varnothing d = 12 / L = 25$ | | | | $\varnothing d = 16 / L = 25$ | |
| A | B | C | H max (*) | TORX® | ARTICOLO (materiale) ITEM (material) | | | | ARTICOLO (materiale) ITEM (material) | |
| | | | | | HSS | | SINTERIZZATO / SINTERED | | HSS | SINTERIZ. |
| | | | | | Standard | Ref. / Cool. | Standard | Ref. / Cool. | Standard | Standard |
| 1,214 | 0,884 | 1,2 | 0,40 | 3 | GT12-T3 | / | GT12K-T3 | / | / | / |
| 1,374 | 0,996 | 1,2 | 0,50 | 4 | GT12-T4 | | GT12K-T4 | | | |
| 1,499 | 1,097 | 1,5 | 1,00 | 5 | GT12-T5 | | GT12K-T5 | | | |
| 1,778 | 1,293 | 1,7 | 1,20 | 6 | GT12-T6 | | GT12K-T6 | | | |
| 2,095 | 1,521 | 1,7 | 1,50 | 7 | GT12-T7 | | GT12K-T7 | | | |
| 2,418 | 1,756 | 2,0 | 1,70 | 8 | GT12-T8 | GT12C-T8 | GT12K-T8 | GT12KC-T8 | / | / |
| 2,603 | 1,889 | 2,0 | 1,70 | 9 | GT12-T9 | GT12C-T9 | GT12K-T9 | GT12KC-T9 | | |
| 2,844 | 2,057 | 2,0 | 2,00 | 10 | GT12-T10 | GT12C-T10 | GT12K-T10 | GT12KC-T10 | | |
| 3,378 | 2,438 | 3,0 | 3,00 | 15 | GT12-T15 | GT12C-T15 | GT12K-T15 | GT12KC-T15 | GT16-T15 | GT16K-T15 |
| 3,962 | 2,857 | 3,5 | 3,00 | 20 | GT12-T20 | GT12C-T20 | GT12K-T20 | GT12KC-T20 | GT16-T20 | GT16K-T20 |
| 4,559 | 3,276 | 4,0 | 3,50 | 25 | GT12-T25 | GT12C-T25 | GT12K-T25 | GT12KC-T25 | GT16-T25 | GT16K-T25 |
| 5,118 | 3,672 | 4,0 | 3,50 | 27 | GT12-T27 | GT12C-T27 | GT12K-T27 | GT12KC-T27 | GT16-T27 | GT16K-T27 |
| 5,651 | 4,064 | 4,5 | 3,50 | 30 | GT12-T30 | GT12C-T30 | GT12K-T30 | GT12KC-T30 | GT16-T30 | GT16K-T30 |
| 6,807 | 4,889 | 5,0 | 4,00 | 40 | GT12-T40 | GT12C-T40 | GT12K-T40 | GT12KC-T40 | GT16-T40 | GT16K-T40 |
| 7,975 | 5,689 | 5,5 | 5,20 | 45 | GT12-T45 | GT12C-T45 | GT12K-T45 | GT12KC-T45 | GT16-T45 | GT16K-T45 |
| 8,991 | 6,502 | 6,0 | 6,00 | 50 | GT12-T50 | GT12C-T50 | GT12K-T50 | GT12KC-T50 | GT16-T50 | GT16K-T50 |
| 11,404 | 8,089 | 7,0 | 7,00 | 55 | GT12-T55 | GT12C-T55 | GT12K-T55 | GT12KC-T55 | GT16-T55 | GT16K-T55 |
| 13,487 | 9,677 | 7,5 | 7,50 | 60 | GT12-T60 | GT12C-T60 | GT12K-T60 | GT12KC-T60 | GT16-T60 | GT16K-T60 |
| 15,773 | 11,264 | 8,0 | 8,00 | 70 | / | / | / | / | GT16-T70 | GT16K-T70 |

| | | | | | per broccatori serie for broaching heads BR-G16M / BRC-G16M | | | | per broccatori serie for broaching heads BR-G16L / BRC-G16L | | | |
|--------|--------|-----|--------------|-------|--|--------------|-------------------------|--------------|--|--------------|-------------------------|--------------|
| | | | | | $\varnothing d = 16 / L = 35$ | | | | $\varnothing d = 16 / L = 45$ | | | |
| A | B | C | H max (*) | TORX® | ARTICOLO (materiale) ITEM (material) | | | | ARTICOLO (materiale) ITEM (material) | | | |
| | | | | | HSS | | SINTERIZZATO / SINTERED | | HSS | | SINTERIZZATO / SINTERED | |
| | | | | | Standard | Ref. / Cool. | Standard | Ref. / Cool. | Standard | Ref. / Cool. | Standard | Ref. / Cool. |
| 3,962 | 2,857 | 3,5 | 3,00 | 20 | GT16M-T20 | GT16MC-T20 | GT16MK-T20 | GT16MKC-T20 | / | / | / | / |
| 4,559 | 3,276 | 4,0 | 3,50 | 25 | GT16M-T25 | GT16MC-T25 | GT16MK-T25 | GT16MKC-T25 | | | | |
| 5,118 | 3,672 | 4,0 | 3,50 | 27 | GT16M-T27 | GT16MC-T27 | GT16MK-T27 | GT16MKC-T27 | | | | |
| 5,651 | 4,064 | 4,5 | 3,50 | 30 | GT16M-T30 | GT16MC-T30 | GT16MK-T30 | GT16MKC-T30 | GT16L-T30 | GT16LC-T30 | GT16LK-T30 | GT16LKC-T30 |
| 6,807 | 4,889 | 5,0 | 4,00 | 40 | GT16M-T40 | GT16MC-T40 | GT16MK-T40 | GT16MKC-T40 | GT16L-T40 | GT16LC-T40 | GT16LK-T40 | GT16LKC-T40 |
| 7,975 | 5,689 | 5,5 | 5,20 | 45 | GT16M-T45 | GT16MC-T45 | GT16MK-T45 | GT16MKC-T45 | GT16L-T45 | GT16LC-T45 | GT16LK-T45 | GT16LKC-T45 |
| 8,991 | 6,502 | 6,0 | 6,00 | 50 | GT16M-T50 | GT16MC-T50 | GT16MK-T50 | GT16MKC-T50 | GT16L-T50 | GT16LC-T50 | GT16LK-T50 | GT16LKC-T50 |
| 11,404 | 8,089 | 7,0 | 7,00 | 55 | GT16M-T55 | GT16MC-T55 | GT16MK-T55 | GT16MKC-T55 | GT16L-T55 | GT16LC-T55 | GT16LK-T55 | GT16LKC-T55 |
| 13,487 | 9,677 | 7,5 | 7,50 | 60 | GT16M-T60 | GT16MC-T60 | GT16MK-T60 | GT16MKC-T60 | GT16L-T60 | GT16LC-T60 | GT16LK-T60 | GT16LKC-T60 |
| 15,773 | 11,264 | 8,0 | 8,00 | 70 | GT16M-T70 | GT16MC-T70 | GT16MK-T70 | GT16MKC-T70 | GT16L-T70 | GT16LC-T70 | GT16LK-T70 | GT16LKC-T70 |

(*) = quota di profondità MAX standard su impronta di vite commerciale / Measure of MAX standard depth imprint by commercial screws

In questi articoli possiamo eseguire i seguenti rivestimenti: HDP RED, WONDER, TiN, INOX PLUS e ZIRINOS > vedi pag.18
Available coatings for the up above mentioned items: HDP RED, WONDER, TiN, INOX PLUS and ZIRINOS > see page 18





Brocche Standard e con passaggio refrigerante per chiavi TORX® PLUS Standard Broaches and with internal flow of coolant for TORX® PLUS wrenches

per Brocciatori Standard serie "BR"
for "BR" Standard Broaching Heads series

per Brocciatori serie "BRC"
for Broaching Heads "BRC" series



I Il profilo TORX® PLUS è un'evoluzione della precedente impronta TORX®. La variante TORX® PLUS consente una maggiore forza di presa sul pezzo e conseguentemente una elevata tenuta della coppia di serraggio. Ciò significa che l'impronta esalobata richiede una profondità della cava relativamente inferiore rispetto alla versione TORX® e nello stesso tempo garantisce più a lungo l'integrità della figura stessa. La geometria ellittica del profilo TORX® PLUS amplia la superficie di contatto consentendo un migliore e più efficace accoppiamento della chiave con la cava esalobata. In questo modo si garantisce una riduzione dello stress di torsione e di conseguenza una vita più lunga dell'utensile. Anche per il profilo TORX e TORX PLUS esiste la versione per brocciatori serie "BRC" che consente di poter lavorare materiali molto tenaci e avere una maggiore durata della broccia e una minore rugosità della cava.

GB TORX® PLUS profile is an enhancement of the older TORX® shape. TORX® PLUS drive system maximizes engagement between driver and fastener and optimizes torque transmission. This means the depth of the profile can be shorter than TORX® old version, even if at the same time TORX® PLUS assures a much longer life of the tools. The elliptically based geometry of the TORX® PLUS profile broadens contact surface guaranteeing a better engagement between driver and fastener than old TORX® shape. This feature virtually eliminates radial stresses and increase tool life. Broaches suitable for broaching heads with internal flow of coolant BRC series are available with TORX PLUS profiles too. The internal flow of coolant helps to machine harder materials and assures a higher broach productivity and a minor roughness on the work-piece.

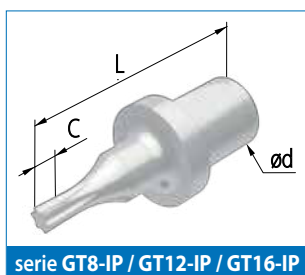
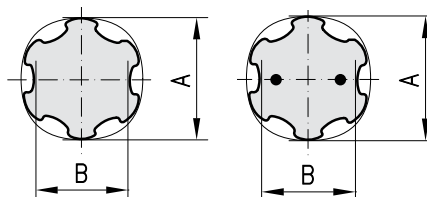

| | | | | | per brocciatori serie for broaching heads BR-G5 | per brocciatori serie for broaching heads BR-G8S / BR-G8M / BR-G8 / BR-G8A BRC-G8M / BRC-G8 / BRC-G8HP | | | | | | |
|-------|-------|-----|-----------|-------|--|---|---|--------------|-------------------------|--------------|----------|--------------|
| | | | | | ød = 5 | | ød = 8 / L = 18 | | | | | |
| | | | | | ARTICOLO (materiale) ITEM (material) | | ARTICOLO (materiale) ITEM (material) | | | | | |
| | | | | | HSS | | HSS | | SINTERIZZATO / SINTERED | | | |
| | | | | | Standard | Standard | Standard | Ref. / Cool. | Standard | Ref. / Cool. | Standard | Ref. / Cool. |
| A | B | C | H max (*) | TORX® | GT5-IP6 | GT5K-IP6 | GT8-IP6 | / | GT8K-IP6 | / | | |
| 1,778 | 1,381 | 1,7 | 1,20 | 6 | GT5-IP7 | GT5K-IP7 | GT8-IP7 | | GT8K-IP7 | | | |
| 2,095 | 1,606 | 1,7 | 1,50 | 7 | GT5-IP8 | GT5K-IP8 | GT8-IP8 | GT8C-IP8 | GT8K-IP8 | GT8KC-IP8 | | |
| 2,418 | 1,860 | 2,0 | 1,70 | 8 | GT5-IP9 | GT5K-IP9 | GT8-IP9 | GT8C-IP9 | GT8K-IP9 | GT8KC-IP9 | | |
| 2,603 | 2,014 | 2,0 | 1,70 | 9 | GT5-IP10 | GT5K-IP10 | GT8-IP10 | GT8C-IP10 | GT8K-IP10 | GT8KC-IP10 | | |
| 2,844 | 2,174 | 2,0 | 2,00 | 10 | GT5-IP15 | GT5K-IP15 | GT8-IP15 | GT8C-IP15 | GT8K-IP15 | GT8KC-IP15 | | |
| 3,378 | 2,606 | 3,0 | 3,00 | 15 | GT5-IP20 | GT5K-IP20 | GT8-IP20 | GT8C-IP20 | GT8K-IP20 | GT8KC-IP20 | | |
| 3,962 | 3,088 | 3,5 | 3,00 | 20 | GT5-IP25 | GT5K-IP25 | GT8-IP25 | GT8C-IP25 | GT8K-IP25 | GT8KC-IP25 | | |
| 4,559 | 3,492 | 4,0 | 3,50 | 25 | / | / | GT8-IP30 | GT8C-IP30 | GT8K-IP30 | GT8KC-IP30 | | |
| 5,651 | 4,391 | 4,5 | 3,50 | 30 | / | / | GT8-IP40 | GT8C-IP40 | GT8K-IP40 | GT8KC-IP40 | | |
| 6,807 | 5,283 | 5,0 | 4,00 | 40 | | | | | | | | |

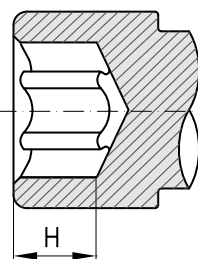
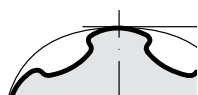



| | | | | | per brocciatori serie for broaching heads BR-G12 / BR-G12B / BR-G12A / BRC-G12 / BRC-G12B | | | | per brocciatori serie for broaching heads BR-G16 | |
|----------|--------|--------------|--------------|----------|--|--------------|-------------------------|-------------|---|------------|
| | | | | | $\varnothing d = 12 / L = 25$ | | | | $\varnothing d = 16 / L = 25$ | |
| A | B | C | H max (*) | TORX® | ARTICOLO (materiale) ITEM (material) | | | | ARTICOLO (materiale) ITEM (material) | |
| | | | | | HSS | | SINTERIZZATO / SINTERED | | HSS | SINTERIZ. |
| Standard | | Ref. / Cool. | | Standard | | Ref. / Cool. | | Standard | Standard | |
| 1,778 | 1,381 | 1,7 | 1,20 | 6 | GT12-IP6 | / | GT12K-IP6 | / | / | / |
| 2,095 | 1,606 | 1,7 | 1,50 | 7 | GT12-IP7 | | GT12K-IP7 | | | |
| 2,418 | 1,860 | 2,0 | 1,70 | 8 | GT12-IP8 | GT12C-IP8 | GT12K-IP8 | GT12KC-IP8 | | |
| 2,603 | 2,014 | 2,0 | 1,70 | 9 | GT12-IP9 | GT12C-IP9 | GT12K-IP9 | GT12KC-IP9 | | |
| 2,844 | 2,174 | 2,0 | 2,00 | 10 | GT12-IP10 | GT12C-IP10 | GT12K-IP10 | GT12KC-IP10 | GT16-IP10 | GT16K-IP10 |
| 3,378 | 2,606 | 3,0 | 3,00 | 15 | GT12-IP15 | GT12C-IP15 | GT12K-IP15 | GT12KC-IP15 | GT16-IP15 | GT16K-IP15 |
| 3,962 | 3,088 | 3,5 | 3,00 | 20 | GT12-IP20 | GT12C-IP20 | GT12K-IP20 | GT12KC-IP20 | GT16-IP20 | GT16K-IP20 |
| 4,559 | 3,492 | 4,0 | 3,50 | 25 | GT12-IP25 | GT12C-IP25 | GT12K-IP25 | GT12KC-IP25 | GT16-IP25 | GT16K-IP25 |
| 5,651 | 4,391 | 4,5 | 3,50 | 30 | GT12-IP30 | GT12C-IP30 | GT12K-IP30 | GT12KC-IP30 | GT16-IP30 | GT16K-IP30 |
| 6,807 | 5,283 | 5,0 | 4,00 | 40 | GT12-IP40 | GT12C-IP40 | GT12K-IP40 | GT12KC-IP40 | GT16-IP40 | GT16K-IP40 |
| 7,975 | 6,141 | 5,5 | 5,20 | 45 | GT12-IP45 | GT12C-IP45 | GT12K-IP45 | GT12KC-IP45 | GT16-IP45 | GT16K-IP45 |
| 8,991 | 6,923 | 6,0 | 6,00 | 50 | GT12-IP50 | GT12C-IP50 | GT12K-IP50 | GT12KC-IP50 | GT16-IP50 | GT16K-IP50 |
| 11,385 | 8,766 | 7,0 | 7,00 | 55 | GT12-IP55 | GT12C-IP55 | GT12K-IP55 | GT12KC-IP55 | GT16-IP55 | GT16K-IP55 |
| 13,442 | 10,350 | 7,5 | 7,50 | 60 | GT12-IP60 | GT12C-IP60 | GT12K-IP60 | GT12KC-IP60 | GT16-IP60 | GT16K-IP60 |
| 15,773 | 12,156 | 8,0 | 8,00 | 70 | / | / | / | / | GT16-IP70 | GT16K-IP70 |

| | | | | | per brocciatori serie for broaching heads BR-G16M / BRC-G16M | | | | per brocciatori serie for broaching heads BR-G16L / BRC-G16L | | | |
|----------|--------|--------------|--------------|----------|---|--------------|-------------------------|--------------|---|-------------|-------------------------|--------------|
| | | | | | $\varnothing d = 16 / L = 35$ | | | | $\varnothing d = 16 / L = 45$ | | | |
| A | B | C | H max (*) | TORX® | ARTICOLO (materiale) ITEM (material) | | | | ARTICOLO (materiale) ITEM (material) | | | |
| | | | | | HSS | | SINTERIZZATO / SINTERED | | HSS | | SINTERIZZATO / SINTERED | |
| Standard | | Ref. / Cool. | | Standard | | Ref. / Cool. | | Standard | Ref. / Cool. | Standard | Ref. / Cool. | |
| 3,962 | 3,088 | 3,5 | 3,00 | 20 | GT16M-IP20 | GT16MC-IP20 | GT16MK-IP20 | GT16MKC-IP20 | / | / | / | / |
| 4,559 | 3,492 | 4,0 | 3,50 | 25 | GT16M-IP25 | GT16MC-IP25 | GT16MK-IP25 | GT16MKC-IP25 | / | / | / | / |
| 5,651 | 4,391 | 4,5 | 3,50 | 30 | GT16M-IP30 | GT16MC-IP30 | GT16MK-IP30 | GT16MKC-IP30 | GT16L-IP30 | GT16LC-IP30 | GT16LK-IP30 | GT16LKC-IP30 |
| 6,807 | 5,283 | 5,0 | 4,00 | 40 | GT16M-IP40 | GT16MC-IP40 | GT16MK-IP40 | GT16MKC-IP40 | GT16L-IP40 | GT16LC-IP40 | GT16LK-IP40 | GT16LKC-IP40 |
| 7,975 | 6,141 | 5,5 | 5,20 | 45 | GT16M-IP45 | GT16MC-IP45 | GT16MK-IP45 | GT16MKC-IP45 | GT16L-IP45 | GT16LC-IP45 | GT16LK-IP45 | GT16LKC-IP45 |
| 8,991 | 6,923 | 6,0 | 6,00 | 50 | GT16M-IP50 | GT16MC-IP50 | GT16MK-IP50 | GT16MKC-IP50 | GT16L-IP50 | GT16LC-IP50 | GT16LK-IP50 | GT16LKC-IP50 |
| 11,385 | 8,766 | 7,0 | 7,00 | 55 | GT16M-IP55 | GT16MC-IP55 | GT16MK-IP55 | GT16MKC-IP55 | GT16L-IP55 | GT16LC-IP55 | GT16LK-IP55 | GT16LKC-IP55 |
| 13,442 | 10,350 | 7,5 | 7,50 | 60 | GT16M-IP60 | GT16MC-IP60 | GT16MK-IP60 | GT16MKC-IP60 | GT16L-IP60 | GT16LC-IP60 | GT16LK-IP60 | GT16LKC-IP60 |
| 15,773 | 12,156 | 8,0 | 8,00 | 70 | GT16M-IP70 | GT16MC-IP70 | GT16MK-IP70 | GT16MKC-IP70 | GT16L-IP70 | GT16LC-IP70 | GT16LK-IP70 | GT16LKC-IP70 |

(*) = quota di profondità MAX standard su impronta di vite commerciale / Measure of MAX standard depth imprint by commercial screws

In questi articoli possiamo eseguire i seguenti rivestimenti: HDP RED, WONDER, TiN, INOX PLUS e ZIRINOS > vedi pag.18
Available coatings for the up above mentioned items: HDP RED, WONDER, TiN, INOX PLUS and ZIRINOS > see page 18





Brocche per profili esterni

Surface broaches



I Sono costituite da dischi in acciaio di robusta struttura che riportano al centro il foro con il profilo da ottenere. Possiamo realizzare una vasta gamma di figure al centro del foro della broccia sulla base di specifiche tecniche del Cliente. La realizzazione di un profilo esterno non richiede uno specifico brocciatore ma semplicemente un adattatore applicabile ad un qualsiasi nostro brocciatore. Sull'adattatore viene fissata la matrice della broccia per l'esterno.

GB They consist of sturdy steel disks with a hole at the centre duly shaped according to the profile to be obtained. Following the technical details supplied by the Customer we can produce surface broaches for a wide range of profiles. To use surface broaches there is no need to have a particular broaching head. In fact the broach can be installed on every kind of broaching head thanks to a special adaptor.

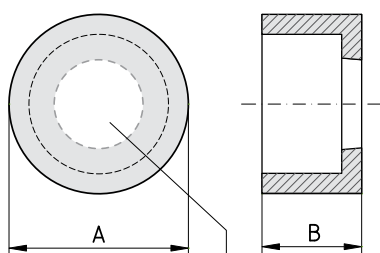

Profili eseguiti su richiesta del cliente.
Specificare caratteristiche e misure necessarie.

Profiles performed upon customer request.
Specify necessary characteristics and measures.

| ARTICOLO (materiale) - ITEM (material) | | A (toll. g6) | B |
|--|--------------|-------------------------|----|
| HSS | SINTERIZZATO | a richiesta / on demand | |
| GE5-□ | GEK5-□ | 16 | 7 |
| GE8-□ | GEK8-□ | 16 | 7 |
| GE8A-□ | GEK8A-□ | 32 | 20 |
| GE12-□ | GEK12-□ | 32 | 20 |
| GE12A-□ | GEK12A-□ | 36 | 20 |
| GE16-□ | GEK16-□ | 42 | 20 |
| GE16L-□ | GEK16L-□ | 20 | 36 |
| GE16M-□ | GEK16M-□ | 62 | 25 |
| GE25-□ | GEK25-□ | | |

ADATTATORI PER BROCCHE PER PROFILI ESTERNI

ADAPTORS FOR SURFACE BROACHES

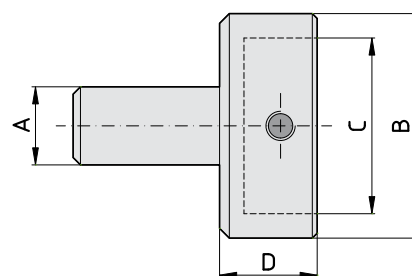

| ARTICOLO (materiale) ITEM (material) | A (toll. g6) | B | C (toll. H7) | D |
|---|-------------------------|----|-----------------|----|
| HSS | | | | |
| A-05 | a richiesta / on demand | | | |
| A-08 | 8 | 26 | 16 | 18 |
| A-08-A | 8 | 26 | 16 | 30 |
| A-12 | 12 | 42 | 32 | 18 |
| A-12-A | 12 | 42 | 32 | 53 |
| A-16 | 16 | 54 | 42 | 18 |
| A-16-L | 16 | 54 | 42 | 40 |
| A-16-M | 16 | 76 | 36 | 28 |
| A-25 | 25 | 79 | 62 | 65 |



Brocche speciali per profili interni/esterni

Special broaches for inner/outer profiles

I BROCCE SPECIALI PER PROFILI DENTATI

Si possono realizzare per cave interne e profili esterni
Se siete interessati a brocche speciali, non comprese nel presente
Catalogo Generale, inviateci questa pagina debitamente compilata.
Sarà nostra cura rispondervi con la massima tempestività.

GB SPECIAL BROACHES FOR TOOTHED PROFILES

We can produce special broaches for holes or surface profiles.
If you did not find in this Catalogue the kind of broach you are
interested in, please fill this page in and send it to us. We will answer
you as soon as possible.

BRIGHETTI MECCANICA S.r.L.

Tel./Phone.: 0039 51 728168

Fax: 0039 51 6463514

E-mail: info@brighetti.it

Data/Date: _____

Società/Company: _____

Indirizzo/Address: _____

Tel./Phone: _____ Fax: _____

E-mail: _____

Contattare il Sig./Attention: _____

Tel./Phone: _____

Materiale da brocciare/Material to broach: _____ Q.tà/Q.ty: _____

Indicare se si tratta di broccia
Special broach for

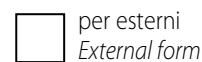
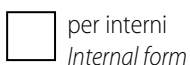

Broccia a denti scanalati

N° denti (Z) _____

Diametro Interno (DI) _____

Diametro Esterno (DE) _____

Misura del dente su DE (L1) _____

Misura del dente su DI (L2) _____

*Raggio di punta (R1) _____

Broccia a denti evolventi

N° denti (Z) _____

Diametro Interno (DI) _____

Diametro Esterno (DE) _____

Modulo (M) _____

Angolo di pressione _____

*Raggio di punta (R1) _____

Broccia dentata

N° denti (Z) _____

Diametro Interno (DI) _____

Diametro Esterno (DE) _____

Raggio di punta (R1) _____

Angolo fra i denti (A1) _____

Angolo del dente (A2) _____

Spline broach

N° of teeth (Z) _____

Inside diameter (DI) _____

Outside diameter (DE) _____

Measure of the teeth on DE (L1) _____

Measure of the teeth on DI (L2) _____

*Internal Radius (R1) _____

Involute broach

N° of teeth (Z) _____

Inside diameter (DI) _____

Outside diameter (DE) _____

Module (M) _____

Pressure angle _____

*Internal Radius (R1) _____

Serration broach

N° of teeth (Z) _____

Inside diameter (DI) _____

Outside diameter (DE) _____

Internal Radius (R1) _____

Angle between teeth (A1) _____

Angle of the tooth (A2) _____

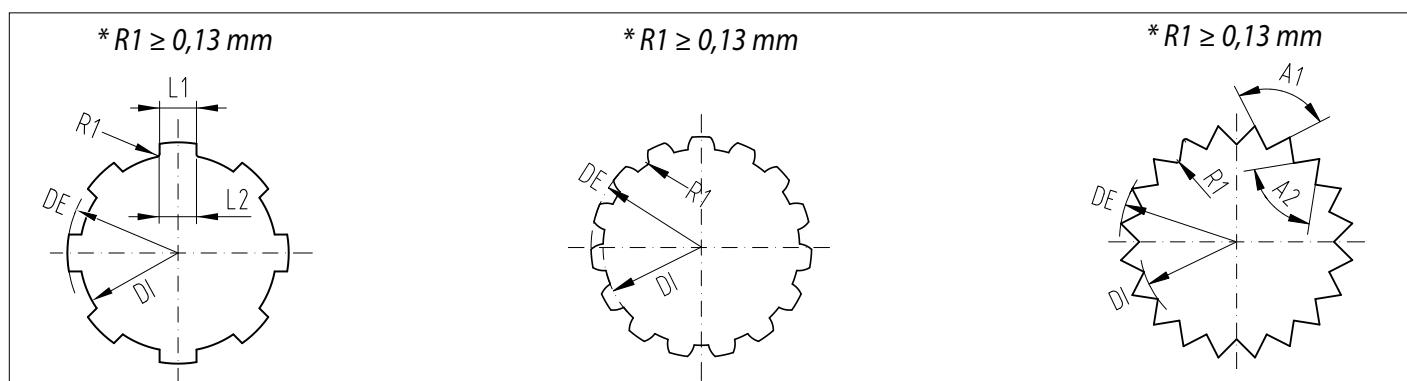



Brocche speciali derivate dalle brocche STD

STD derived special broaches

I Per questo tipo di figura è sufficiente indicare le quote "A" per il doppio quadro o doppio esagono, e le quote "D" e "S" per il doppio "D".

GB For double hexagon or double square broaches it is enough to indicate measure "A", while for double "D" broaches it is necessary to indicate measures "D" and "S".

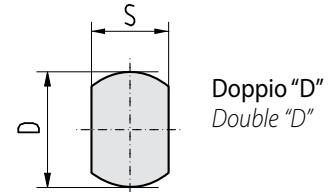
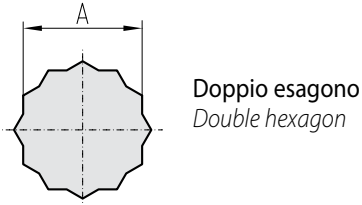
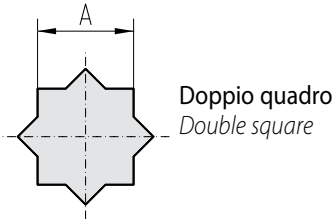

Brocche speciali per viti antimanomissione

Special broaches to anti-tamper screws

I Produciamo brocche speciali che creano nella testa della vite una figura poligonale Esagonale (G...V) o Torx® (G...TV) con al centro un perno. L'accesso a questo tipo di viti antimanomissione, è consentito solo con chiavi speciali. Sono disponibili a magazzino alcune misure di brocche speciali, come da seguente tabella.

GB Anti-tamper screws is a special configuration of the screw heads that it's can be try only with a special keys for their handling. We can supply special broaches and milling tools, to obtain the hollow and the pin to the polygonal figure Hexagonal (G...V) or Torx (G...TV) Check, with the tables below, which kind of profile may to get.



| ARTICOLO-ITEM (materiale - material) | A | øB | C |
|---|---|-----|-----|
| HSS | | | |
| G □ V-E-3 | 3 | 1,5 | 2,5 |
| G □ V-E-4 | 4 | 2,1 | 3 |
| G □ V-E-5 | 5 | 2,8 | 3,5 |
| G □ V-E-6 | 6 | 2,9 | 4 |
| G □ V-E-8 | 8 | 3,9 | 6 |

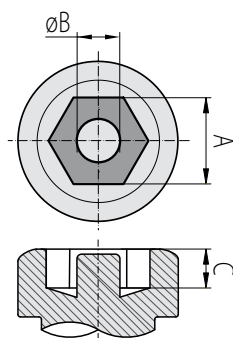

specificare la misura della broccia (es.: G8V..., G12V..., ecc)
specify the size of the broach (es.: G8V..., G12V..., etc)

| ARTICOLO-ITEM (materiale - material) | A | øB | C |
|---|-----|-----|-----|
| HSS | | | |
| GT □ V - T15 | T15 | 1 | 1,4 |
| GT □ V - T20 | T20 | 1,4 | 1,6 |
| GT □ V - T25 | T25 | 1,8 | 2 |
| GT □ V - T27 | T27 | 2 | 2,4 |
| GT □ V - T30 | T30 | 2,5 | 3 |
| GT □ V - T40 | T40 | 3 | 3,3 |
| GT □ V - T45 | T45 | 3,2 | 4 |
| GT □ V - T50 | T50 | 3,6 | 4,5 |

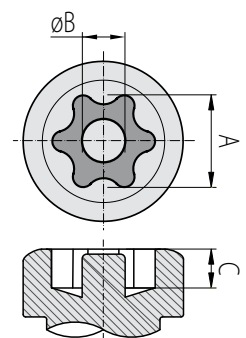

specificare la misura della broccia (es.: GT8V..., GT12V..., ecc)
specify the size of the broach (es.: GT8V..., GT12V..., etc)

Mini fresa a carotare per cava viti antimanomissione

Mini milling core drilling for anti tampering screws

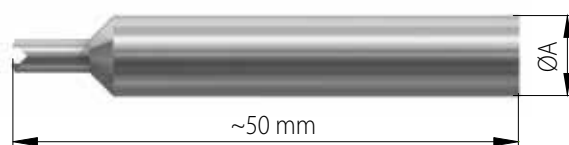

| ARTICOLO-ITEM (materiale - material) | ØA (mm) |
|---|-------------------------------|
| FG8 | 8 a richiesta on demand |
| FG12 | 12 |



Calibri e tamponi di controllo G/NG per profili poligonali interni, esterni e per sedi di chiavette

G/NG plug gauges and ring gauges for internal and external polygonal profile and for keyway slots



I LA NOSTRA NUOVA ESPERIENZA: STRUMENTI DI CONTROLLO PER PROFILI POLIGONALI

Proseguendo nella politica di innovazione e aggiornamento del nostro parco macchine, ci siamo attrezzati con i più recenti strumenti di controllo per la gestione dei processi di produzione in grado di operare nel campo delle attrezzature per il controllo dimensionale del pezzo.

Il primo passaggio è stato l'acquisizione di **programmi software 3D** per lo sviluppo di disegni esecutivi bidimensionali e tridimensionali in un ambiente di massima precisione.

Il sistema software 3D ci consente di offrire ai nostri Clienti un servizio di assistenza gratuita nella fase di definizione dimensionale dell'utensile (brocche, inserti, calibri e tamponi di controllo) mediante progettazione del disegno esecutivo da sottoporre all'approvazione del Cliente.

Il secondo passaggio è stato l'acquisizione di un **proiettore di profili che combina le tecnologie di misura ottica/video ad**

GB OUR NEW EXPERIENCE: CONTROL INSTRUMENTS FOR POLYGONAL PROFILES

Continuing with our policy of innovation and updating of our machinery pool, we equipped ourselves with the most state-of-the-art control instruments for the management of production processes able to operate in the field of piece dimensional control equipment.

*The first step was the acquisition of **3D software programs** for the development of bi-dimensional and three-dimensional executive drawings in an environment requiring absolute precision.*

The 3D software system allows us to offer our Clients a free support service at the tool's dimensional definition stage (broaching heads, inserts, gauges and control buffers) by designing the executive drawing to be submitted to the Client for approval.

*The second stage was the acquisition of a **profile projector, which combines high-resolution optical/video measurement technologies**, guaranteeing a "measurement uncertainty" of μm .*

The metrological software allows acquisition of the profile image



alta risoluzione garantendo una "incertezza di misura" di 2 μm .

Il software metrologico permette l'acquisizione immagine del profilo dell'utensile lavorato e la creazione di un report contenente le caratteristiche dimensionali complete di tolleranze e la gestione di file dxf per misure comparative mediante sovrapposizione dei due profili.



of the tool worked and the generation of a report containing the dimensional characteristics complete of tolerances as well as the management of a dxf file for comparative measurements by the two profiles being superimposed.

G/NG PLUG GAUGES AND RING GAUGES FOR INTERNAL AND EXTERNAL POLYGONAL PROFILES

After many years of experience gained in the market of tooling for broaching/slotting, we thought of making ourselves available for all problems relative to control systems for internal/external polygonal profiles according to ruling national and international standards.

For this, we implemented a series of G/NG plug gauges for hexagonal and square TORX profiles and for keyway slots.

We also engaged in the field of splined profiles both with G/NG rings gauges for the control of straight teeth, splined and evolving shafts and G/NG plug gauges to ensure a correct dimensional construction of the internal profile.

Normally, for control plug gauges and ring gauges implemented according to the most used regulations these are available ex stock. In other cases, they get constructed with the forms and dimensional characteristics according to Client needs.

On request, we are able to provide a calibration certification.

Plug gauges for TORX, TORX PLUS, hexagons, squares and keyways are compliant with ISO-DIN standards.

Plug gauges: hexagonal, square and all other polygons it's has special dimensions and tolerances, these products doesn't follows the international standards, and are therefore defined by the customers.

As regards the ring gauges to external profiles and plug gauges to internal profiles, They will control spline or toothings profiles, the manufacturing of its is on compliance with the measures required by customers or international standards.

These rings and gauges, obviously, it's executed alone to verifies the correct executions of the profiles.

CALIBRI E TAMPONI DI CONTROLLO G/NG PER PROFILI POLIGONALI INTERNI E ESTERNI

Dopo tanti anni di esperienza maturata sul mercato degli utensili per la brocciatura/stozzatura abbiamo pensato di metterci al servizio di tutte le problematiche relative ai sistemi di controllo per profili poligonali interni/esterni secondo le normative nazionali e internazionali vigenti.

Per questo abbiamo realizzato una serie di calibri a tampone G/NG per profili TORX, esagonali, quadri e per sedi di chiavette.

Ci siamo cimentati anche nel campo dei profili scanalati sia con anelli G/NG per il controllo di alberi scanalati a denti diritti ed evolventi e tamponi G/NG per assicurare una corretta costruzione dimensionale del profilo interno.

Normalmente per i calibri a tampone di controllo realizzati secondo le normative più in uso sono disponibili a magazzino. Negli altri casi vengono prodotti nelle forme e caratteristiche dimensionali secondo le esigenze del Cliente.

A richiesta possiamo fornire la certificazione di taratura.

La costruzione di tamponi di controllo nei profili TORX e TORX PLUS per interni ed esterni, tamponi esagonali, tamponi quadri e tamponi per il controllo sedi di chiavette, avvengono nel rispetto delle tolleranze previste dalle normative ISO-DIN.

I tamponi: esagonali, quadri e gli altri poligoni possono avere dimensioni e tolleranze speciali, tali prodotti esulano dalle normative internazionali, e sono quindi definite dai clienti.

Per quanto riguardano i tamponi ad anello per profili esterni e tamponi per profili interni, relativamente alla verifica di profili scanalati o dentature, la costruzione degli stessi avviene nel rispetto della misure richieste dai clienti o dalle normative internazionali.

Tali anelli e calibri, per lo più, vengono eseguiti singolarmente per verificare la corrette esecuzioni dei profili.





CALIBRI A TAMPONE DI CONTROLLO PER PROFILI POLIGONALI PLUG GAUGES FOR POLYGONAL PROFILES

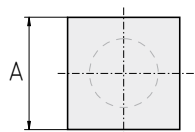

TAMPONE DI CONTROLLO PER IMPRONTA QUADRA

PLUG GAUGE FOR SQUARE MARK

Il tampone "passa" DEVE entrare liberamente nell'impronta poligonale di tipo quadro alla profondità stabilita secondo la normativa di riferimento.

tamponi quadri passa-non-passa normati ISO
Square plug gauges GO - NO GO compliant with ISO standard

| A | A |
|--------|-------|
| TQ 1 | TQ 10 |
| TQ 1,5 | TQ 11 |
| TQ 2 | TQ 12 |
| TQ 2,5 | TQ 13 |
| TQ 3 | TQ 14 |
| TQ 3,5 | TQ 15 |
| TQ 4 | TQ 16 |
| TQ 4,5 | TQ 17 |
| TQ 5 | TQ 18 |
| TQ 5,5 | TQ 19 |
| TQ 6 | TQ 20 |
| TQ 7 | TQ 21 |
| TQ 8 | TQ 22 |
| TQ 9 | |

The "GO" plug gauge MUST freely enter the square-type polygonal mark at the depth established according to the reference standard.

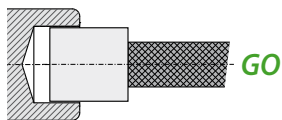

Il tampone "non passa" NON deve entrare nell'impronta poligonale di tipo quadro.

The "NO GO" plug gauge MUST NOT enter the square-type polygonal mark.

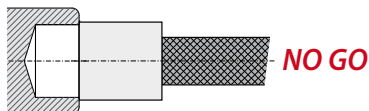

Le misure NON indicate nella tabella sono da considerarsi speciali.

The measures NOT indicated on the table are to be considered special.

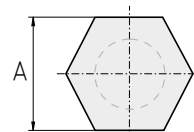

TAMPONE DI CONTROLLO PER IMPRONTA ESAGONALE

PLUG GAUGE FOR HEXAGONAL MARK

Il tampone "passa" DEVE entrare liberamente nell'impronta poligonale di tipo esagonale alla profondità stabilita secondo la normativa di riferimento.

The "GO" plug gauge MUST freely enter the hexagonal-type polygonal mark at the depth established according to the reference standard.

tamponi esagonali passa-non-passa normati ISO
Hexagonal plug gauges GO - NO GO compliant with ISO standard

| A | A |
|--------|-------|
| TE 1,5 | TE 10 |
| TE 2 | TE 12 |
| TE 2,5 | TE 14 |
| TE 3 | TE 17 |
| TE 4 | TE 19 |
| TE 5 | TE 22 |
| TE 6 | TE 27 |
| TE 8 | |

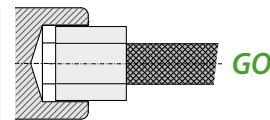

Il tampone "non passa" NON deve entrare nell'impronta poligonale di tipo esagonale.

The "NO GO" plug gauge MUST NOT enter the hexagonal-type polygonal mark.

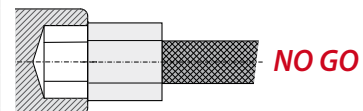

Le misure NON indicate nella tabella sono da considerarsi speciali.

The measures NOT indicated on the table are to be considered special.

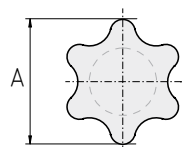

TAMPONE DI CONTROLLO PER IMPRONTA TORX (*)

PLUG GAUGE FOR TORX MARK (*)

Il tampone "passa" DEVE entrare liberamente nell'impronta poligonale di tipo Torx alla profondità stabilita secondo la normativa di riferimento.

The "GO" plug gauge MUST freely enter the Torx-type polygonal mark at the depth established according to the reference standard.

tamponi Torx passa-non-passa normati ISO
Torx plug gauges GO - NO GO compliant with ISO standard

| A | A |
|-------|-------|
| TT 5 | TT 30 |
| TT 6 | TT 40 |
| TT 8 | TT 45 |
| TT 10 | TT 50 |
| TT 15 | TT 55 |
| TT 20 | TT 60 |
| TT 25 | TT 70 |
| TT 27 | |

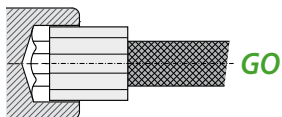

Il tampone "non passa" NON deve entrare nell'impronta poligonale di tipo Torx.

The "NO GO" plug gauge MUST NOT enter the Torx-type polygonal mark.

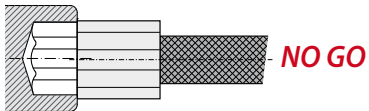

Le misure NON indicate nella tabella sono da considerarsi speciali.

The measures NOT indicated on the table are to be considered special.

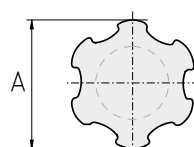

TAMPONE DI CONTROLLO PER IMPRONTA TORX-PLUS (*)

PLUG GAUGE FOR TORX-PLUS MARK (*)

Il tampone "passa" DEVE entrare liberamente nell'impronta poligonale di tipo Torx Plus alla profondità stabilita secondo la normativa di riferimento.

The "GO" plug gauge MUST freely enter the Torx Plus-type polygonal mark at the depth established according to the reference standard.

tamponi Torx-Plus passa-non-passa normati ISO
Torx Plus plug gauges GO - NO GO compliant with ISO standard

| A | A |
|--------|--------|
| TIP 6 | TIP 40 |
| TIP 8 | TIP 45 |
| TIP 10 | TIP 50 |
| TIP 15 | TIP 55 |
| TIP 20 | TIP 60 |
| TIP 25 | TIP 70 |
| TIP 30 | |

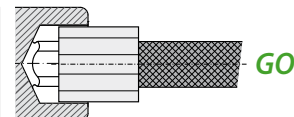

Il tampone "non passa" NON deve entrare nell'impronta poligonale di tipo Torx-Plus.

The "NO GO" plug gauge MUST NOT enter the Torx Plus-type polygonal mark.

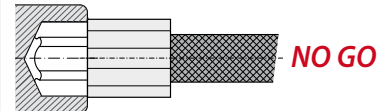

Le misure NON indicate nella tabella sono da considerarsi speciali.

The measures NOT indicated on the table are to be considered special.

* Per i calibri TORX® e TORX®-PLUS il profilo della figura si sviluppa in 5 lobi anziché 6 lobi. Questa soluzione contribuisce a migliorare sensibilità la precisione e la stessa finitura del tampone.

* For TORX® and TORX®-PLUS gauges, the figure profile is developed in 5 lobes instead of 6 lobes. This solution helps to sensitively improve the accuracy and finish of the gauge itself.



TAMPONI DI CONTROLLO PER SEDI DI CHIAVETTE

PLUG GAUGES FOR KEYWAY SLOTS

Possiamo realizzare questa tipologia di tamponi con dimensione a richiesta
We can manufacture plug gauges with dimensions on request



ANELLE DI CONTROLLO PER PROFILI DENTATI ESTERNI

RING GAUGES FOR EXTERNAL TOOTHED PROFILES

Misure a richiesta / Measures at request

| tampone "GO" "GO" ring gauges | tampone "NO GO" "NO GO" ring gauges |
|----------------------------------|--|
| TES-G | TES-NG |



Possiamo realizzare tamponi di controllo per dentature secondo le normative internazionali più diffuse.
We can manufacture ring gauges for tothing according to the most common international standards.



BT/BTA Sistemi di brocciatura sedi di chiavette di trascinamento su macchine CNC

*BT/BTA - Internal Keyway broaching system
on CNC machines tools*



SCANSIONA IL QR CODE CON I TUOI
DISPOSITIVI E SCOPRI IL SISTEMA "BT/BTA"

SCAN THE QR CODE BY YOUR DEVICES AND
DISCOVER THE "BT/BTA" SYSTEM

IT



<https://bit.ly/49kft4U>

GB



<https://bit.ly/484Gh8l>



I CONSIDERAZIONI GENERALI

I **sistemi di brocciatura BT-BTA** sono stati studiati per l'esecuzione di sedi di chiavette e profili interni/esterni di dimensioni importanti su macchine CNC.

Questo significa che l'operazione di brocciatura viene eseguita in un contesto di operazioni sequenziali sempre sulla stessa macchina: dopo l'esecuzione di operazioni di tornitura, foratura, fresatura, etc. senza dover smontare il pezzo dalla macchina si può procedere in sequenza alla brocciatura della sede della chiavetta con evidenti vantaggi economici e soprattutto di precisione.

Due sono le soluzioni proposte per questo tipo di operazione.

Il primo è il **sistema BT** – composto da uno stelo più l'inserto. Questo utensile è particolarmente adatto a macchine utensili CNC (torni, centri di lavoro, fresatrici) che dispongono dell'asse "y" e di macchine utensili CNC specifiche per il lavoro di brocciatura (stozzatrici). L'esatto posizionamento dell'utensile rispetto al foro interno da brocciare viene assicurato utilizzando tutte le funzioni operative del CNC.

L'utensile è disponibile in due diametri di presa diversi: Ø 25 e Ø 32. La profondità utile di brocciatura va da un minimo di mm 30 a un massimo di mm 200.

Il secondo è il **sistema BTA**, composto dal sistema BT (porta-inserto + inserto), più la bussola eccentrica graduata. Questo sistema a tre pezzi è adatto per macchine utensili CNC che non dispongono dell'asse "y". Infatti, qualora il tornio non disponga dell'asse "y", la concentricità dell'utensile BTA rispetto al foro interno del pezzo da brocciare, viene assicurata manovrando opportunamente, in un verso o nell'altro, la bussola eccentrica. Agendo sulla scala graduata della bussola è possibile correggere errori di simmetria che sono spesso presenti in questo tipo di lavorazione. La bussola eccentrica è disponibile in tre misure di diametro esterno: 32-40-50 e l'asse del foro interno è spostata di 0,5 mm rispetto all'asse della bussola.

La soluzione del **sistema BTA**, per il quale è stata rilasciata registrazione brevettuale, rappresenta la vera novità nel campo della brocciatura di sedi di chiavette. Tutte le soluzioni attualmente presenti sul Mercato, sono caratterizzate dall'impiego di "utensili fissi", cioè non registrabili. Questo significa che la centratura angolare dell'utensile avviene per tentativi successivi e comunque non guidati da una scala graduata che semplifica e velocizza l'operazione stessa.

GB GENERAL INFORMATION

The **BT/BTA broaching systems** have been developed to machine internal keyways inside blind or through holes using CNC machine tools. By using BT/BTA broaching systems it is not necessary to change machine tool to complete the production process. After the turning, the milling, the drilling, etc. it is possible to proceed with the broaching operation of the internal keyway without taking the work-piece off the machine tool, which means a great saving in time and money, and the result of the machining will be much more precise.

We propose two different solution for the internal keyway machining.

The first is the **BT system**, made of the insert holder and the insert, which is used on CNC machines (lathe, milling machines, machining centre) with a Y axis or on slotting machines. The perfect alignment between the tools and the work-piece is granted by the specific function of the CNC machine.

The insert holder is available with cylindrical connection to the machine, two different measures in particular: Ø25 and Ø 32. The maximum broaching depth goes from 30 mm to 200 mm.

The second is the **BTA system**, made of the BT system (insert holder + insert) and the eccentric graduated bush. This "three tools broaching system" is useful when a machine tool without a Y axis is to be used. In this case, it is the eccentric graduated bush the one which guarantees the perfect alignment between the broaching tools and the work-piece. The alignment mistakes can be corrected by turning, clockwise or counter-clockwise, the eccentric bush following the notches engraved on its collar. The eccentric graduated bush is available in three different measures of the outside diameter: 32 – 40 – 50 and the inside hole axis is shifted 0,5 mm from the bush axis.

The **BTA broaching system**, which are patented, are a great novelty in the field of the internal keyway machining on CNC.

At the time being, in fact, all internal keyways broaching systems on CNC machine tools available on the market use "steady tools", which means that the tools are not adjustable. As a consequence, the correction of the alignment of the tools needs several attempts and it is not driven by a graduated scale which, in the case of BT/BTA, made this operation faster and easier.





I INSERTI MONOTAGLIANTE PER SEDI CHIAVETTE (IN)

Sono realizzati in acciaio sinterizzato con rivestimento TiN. Il tipo di acciaio e il rivestimento conferiscono all'inserto una alta durezza che permette di resistere ottimamente ai ripetuti urti che questo tipo di lavorazione comporta. E' importante rilevare che per taluni inserti, in particolare per inserti con **tolleranze P9 e H7**, si possono realizzare smussi di 0,2x45°. In questo modo durante e contemporaneamente la esecuzione della sede della chiave viene eliminata ogni tipo di bava formatasi durante la lavorazione. La particolare forma degli inserti consente di eseguire 2/3 volte la riaffilatura con conseguente riduzione dei costi. Le misure degli inserti espressi nella fig. 1 sono sempre disponibili a magazzino.

INSERTI IN ACCIAIO SINTERIZZATO

Gli inserti sono prodotti in misura metrica e in pollici.

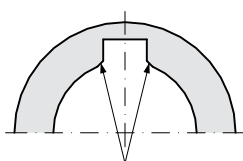

smusso / chamfer 0.2x45°

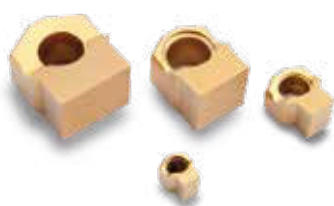

misura metrica / metric size

| ARTICOLO ITEM (material) | TOLLER. TOLER. | L1 (mm) | L2 (mm) | L3 (mm) | L4 (mm) | L5 (mm) | L6 (mm) | UT |
|--------------------------------|-------------------|------------|------------|------------|------------|------------|------------|--------------|
| SINTERIZ. | | | | | | | | |
| IN-02 | P9 | 1,994 | 5 | 6,5 | 5 | 6 | 1,3 | UT-02 |
| | P9 SM | | | | | | 1,09 | |
| | H7 | 2,010 | | | | | 1,3 | |
| | H7 SM | | | | | | 1,09 | |
| | D10 | 2,060 | | | | | 1,3 | |
| C11 | 2,120 | 1,3 | | | | | | |
| IN-03 | P9 | 2,994 | 6,08 | 6,5 | 5 | 7,5 | 2 | UT-03 |
| | P9 SM | | | | | | 1,42 | |
| | H7 | 3,010 | | | | | 2 | |
| | H7 SM | | | | | | 1,42 | |
| | D10 | 3,060 | | | | | 2 | |
| C11 | 3,120 | 2 | | | | | | |
| IN-04 | P9 | 3,988 | 6,08 | 7 | 5 | 8 | 2,6 | UT-04 |
| | P9 SM | | | | | | 2,07 | |
| | H7 | 4,012 | | | | | 2,6 | |
| | H7 SM | | | | | | 2,07 | |
| | D10 | 4,078 | | | | | 2,6 | |
| C11 | 4,145 | 2,6 | | | | | | |
| IN-05 | P9 | 4,988 | 6,08 | 7 | 5 | 8 | 3 | UT-05 |
| | P9 SM | | | | | | 2,74 | |
| | H7 | 5,012 | | | | | 3 | |
| | H7 SM | | | | | | 2,74 | |
| | D10 | 5,078 | | | | | 3 | |
| C11 | 5,145 | 3 | | | | | | |
| IN-06 | P9 | 5,988 | 10,08 | 9 | 6 | 13,5 | 4 | UT-06 |
| | P9 SM | | | | | | 3 | |
| | H7 | 6,012 | | | | | 4 | |
| | H7 SM | | | | | | 3 | |
| | D10 | 6,078 | | | | | 4 | |
| C11 | 6,145 | 4 | | | | | | |
| IN-08 | P9 | 7,985 | 10,08 | 9 | 6 | 13,5 | 4,5 | UT-08 |
| | P9 SM | | | | | | 3,78 | |
| | H7 | 8,015 | | | | | 4,5 | |
| | H7 SM | | | | | | 3,78 | |
| | D10 | 8,098 | | | | | 4,5 | |
| C11 | 8,170 | 4,5 | | | | | | |
| IN-10 | P9 | 9,985 | 13,1 | 14 | 10 | 18,5 | 6 | UT-10 |
| | P9 SM | | | | | | 3,88 | |
| | H7 | 10,015 | | | | | 6 | |
| | H7 SM | | | | | | 3,88 | |
| | D10 | 10,098 | | | | | 6 | |
| C11 | 10,170 | 6 | | | | | | |

segue / continued >>

GB ONE CUTTING EDGE FOR INTERNAL KEYWAY (IN)

Inserts are made in sintered steel with a TiN coating. The material and the coating give to the insert a great hardness and let it bear in the best way possible the great number of hits that are typical of this kind of machining. It's important to point out that for some inserts (in particular inserts with **P9 and H7** tolerances), a 0,2x45° chamfer can be realized. This chamfer prevents the flash from forming during the machining of the keyseat.

Inserts can be re-grinded twice or three times. This feature reduces production costs. All insert sizes indicated in picture 1 are always available in stock.

SINTERED STEEL INSERTS

Inserts are produced with metric and inches sizes.



figura 1 - INSERTO PER SEDI DI CHIAVETTE (IN)
picture 1 - INSERT FOR INTERNAL KEYWAY (IN)

| ARTICOLO ITEM (material) | TOLLER. TOLER. | L1 (mm) | L2 (mm) | L3 (mm) | L4 (mm) | L5 (mm) | L6 (mm) | UT |
|--------------------------------|-------------------|------------|------------|------------|------------|------------|------------|-----------------|
| SINTERIZ. | | | | | | | | |
| IN-12 | P9 | 11,982 | 13,1 | 14 | 10 | 18,5 | 6,5 | UT-12 |
| | P9 SM | | | | | | 3,89 | |
| | H7 | 12,018 | | | | | 6,5 | |
| | H7 SM | | | | | | 3,89 | |
| | D10 | 12,120 | | | | | 6,5 | |
| C11 | 12,205 | 6,5 | | | | | | |
| IN-14 | P9 | 13,982 | 18 | 14 | 10 | 22 | 7 | UT-14/16 |
| | P9 SM | | | | | | 4,71 | |
| | H7 | 14,018 | | | | | 7 | |
| | H7 SM | | | | | | 4,71 | |
| | D10 | 14,120 | | | | | 7 | |
| C11 | 14,205 | 7 | | | | | | |
| IN-16 | P9 | 15,982 | 18 | 14 | 10 | 22 | 8 | UT-14/16 |
| | P9 SM | | | | | | 5,53 | |
| | H7 | 16,018 | | | | | 8 | |
| | H7 SM | | | | | | 5,53 | |
| | D10 | 16,120 | | | | | 8 | |
| C11 | 16,205 | 8 | | | | | | |
| IN-18 | P9 * | 17,982 | 26 | 18 | 10 | 30 | 9 | UT-18/25 |
| | P9 SM * | | | | | | 5,67 | |
| | H7 * | 18,018 | | | | | 9 | |
| | H7 SM * | | | | | | 5,67 | |
| | D10 * | 18,120 | | | | | 9 | |
| C11 * | 18,205 | 9 | | | | | | |
| IN-20 | P9 * | 19,978 | 26 | 18 | 10 | 30 | 10 | UT-18/25 |
| | P9 SM * | | | | | | 6,29 | |
| | H7 * | 20,021 | | | | | 10 | |
| | H7 SM * | | | | | | 6,29 | |
| | D10 * | 20,149 | | | | | 10 | |
| C11 * | 20,240 | 10 | | | | | | |
| IN-22 | P9 * | 21,978 | 26 | 18 | 10 | 30 | 11 | UT-18/25 |
| | P9 SM * | | | | | | 6,79 | |
| | H7 * | 22,021 | | | | | 11 | |
| | H7 SM * | | | | | | 6,79 | |
| | D10 * | 22,149 | | | | | 11 | |
| C11 * | 22,240 | 11 | | | | | | |
| IN-25 | P9 * | 24,978 | 26 | 18 | 10 | 30 | 12 | UT-18/25 |
| | P9 SM * | | | | | | 7,02 | |
| | H7 * | 25,021 | | | | | 12 | |
| | H7 SM * | | | | | | 7,02 | |
| | D10 * | 25,149 | | | | | 12 | |
| C11 * | 25,240 | 12 | | | | | | |

* Per queste misure di inserti si consiglia di suddividere la lavorazione in due fasi: sgrossatura e finitura.

* For these insert sizes, we recommend machining in two steps: roughing and finishing.

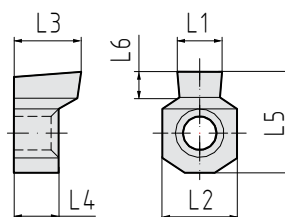

misura in pollici / inches size

| ARTICOLO ITEM (material) | TOLLER. TOLER. | L1 (mm) | L1 (inch) | L2 (inch) | L3 (inch) | L4 (inch) | L5 (inch) | L6 (inch) | UT |
|--------------------------------|-------------------|------------|--------------|--------------|--------------|--------------|--------------|--------------|-------|
| SINTERIZ. | | | | | | | | | |
| IN-3/32" | P9 | 2,375 | 0,093 | 0,197 | 0,236 | 0,197 | 0,256 | 0,055 | UT-02 |
| | H7 | 2,391 | 0,094 | | | | | | |
| | D10 | 2,441 | 0,096 | | | | | | |
| | C11 | 2,501 | 0,098 | | | | | | |
| IN-1/8" | P9 | 3,163 | 0,124 | 0,236 | 0,276 | 0,197 | 0,315 | 0,091 | UT-03 |
| | H7 | 3,187 | 0,125 | | | | | | |
| | D10 | 3,253 | 0,128 | | | | | | |
| | C11 | 3,320 | 0,131 | | | | | | |
| IN-5/32" | P9 | 3,969 | 0,156 | 0,236 | 0,276 | 0,197 | 0,315 | 0,114 | UT-04 |
| | H7 | 3,981 | 0,157 | | | | | | |
| | D10 | 4,047 | 0,159 | | | | | | |
| | C11 | 4,114 | 0,162 | | | | | | |
| IN-3/16" | P9 | 4,750 | 0,187 | 0,236 | 0,276 | 0,197 | 0,315 | 0,130 | UT-05 |
| | H7 | 4,775 | 0,188 | | | | | | |
| | D10 | 4,841 | 0,191 | | | | | | |
| | C11 | 4,908 | 0,193 | | | | | | |
| IN-1/4" | P9 | 6,335 | 0,249 | 0,396 | 0,354 | 0,236 | 0,531 | 0,159 | UT-06 |
| | H7 | 6,365 | 0,251 | | | | | | |
| | D10 | 6,448 | 0,254 | | | | | | |
| | C11 | 6,520 | 0,257 | | | | | | |
| IN-9/32" | P9 | 7,129 | 0,281 | 0,396 | 0,354 | 0,236 | 0,531 | 0,169 | UT-08 |
| | H7 | 7,159 | 0,282 | | | | | | |
| | D10 | 7,242 | 0,285 | | | | | | |
| | C11 | 7,314 | 0,288 | | | | | | |

segue / continued >>

| ARTICOLO ITEM (material) | TOLLER. TOLER. | L1 (mm) | L1 (inch) | L2 (inch) | L3 (inch) | L4 (inch) | L5 (inch) | L6 (inch) | UT |
|--------------------------------|-------------------|------------|--------------|--------------|--------------|--------------|--------------|--------------|----------|
| SINTERIZ. | | | | | | | | | |
| IN-5/16" | P9 | 7,923 | 0,312 | 0,396 | 0,354 | 0,236 | 0,531 | 0,188 | UT-08 |
| | H7 | 7,953 | 0,313 | | | | | | |
| | D10 | 8,036 | 0,316 | | | | | | |
| | C11 | 8,108 | 0,319 | | | | | | |
| IN-3/8" | P9 | 9,510 | 0,374 | 0,516 | 0,551 | 0,394 | 0,728 | 0,250 | UT-10 |
| | H7 | 9,540 | 0,376 | | | | | | |
| | D10 | 9,623 | 0,379 | | | | | | |
| | C11 | 9,695 | 0,382 | | | | | | |
| IN-7/16" | P9 | 11,095 | 0,437 | 0,516 | 0,551 | 0,394 | 0,728 | 0,250 | UT-12 |
| | H7 | 11,131 | 0,438 | | | | | | |
| | D10 | 11,233 | 0,442 | | | | | | |
| | C11 | 11,318 | 0,446 | | | | | | |
| IN-1/2" | P9 | 12,682 | 0,499 | 0,516 | 0,551 | 0,394 | 0,728 | 0,300 | UT-12 |
| | H7 | 12,718 | 0,501 | | | | | | |
| | D10 | 12,820 | 0,505 | | | | | | |
| | C11 | 12,905 | 0,508 | | | | | | |
| IN-9/16" | P9 | 14,270 | 0,562 | 0,709 | 0,551 | 0,394 | 0,866 | 0,275 | UT-14/16 |
| | H7 | 14,306 | 0,563 | | | | | | |
| | D10 | 14,408 | 0,567 | | | | | | |
| | C11 | 14,493 | 0,571 | | | | | | |
| IN-5/8" | P9 | 15,857 | 0,624 | 0,709 | 0,551 | 0,394 | 0,866 | 0,312 | UT-14/16 |
| | H7 | 15,893 | 0,626 | | | | | | |
| | D10 | 15,995 | 0,630 | | | | | | |
| | C11 | 16,080 | 0,633 | | | | | | |
| IN-3/4" | P9 | 19,028 | 0,749 | 1,024 | 0,709 | 0,394 | 1,181 | 0,393 | UT-18/25 |
| | H7 | 19,071 | 0,751 | | | | | | |
| | D10 | 19,199 | 0,756 | | | | | | |
| | C11 | 19,290 | 0,759 | | | | | | |

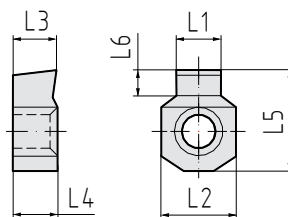
INSERTI IN METALLO DURO
HARD METAL INSERTS

SONO DISPONIBILI GLI INSERTI ANCHE IN
METALLO DURO, COMPATIBILI CON I
PORTA INSERTI serie (UT)

Misure da 3 a 12 mm > vedi pag. 69

INSERTS IS AVAILABLE IN HARD METAL,
COMPATIBLE BY INSERT HOLDER (UT)
Sizes from 3 to 12mm > see page 69



Utensili per MACCHINE A CONTROLLO

Tools for CNC MACHINES

I PORTA-INSERTO MONOTAGLIANTE PER MACCHINE A CONTROLLO

È realizzato in acciaio bonificato e temprato: in questo modo viene garantita una ottima resistenza alla compressione.

L'utensile (UT) è disponibile in due diametri di presa alla macchina: 25 mm e 32 mm. Per ogni diametro di presa abbiamo due diverse misure di lunghezza gambo: una lunghezza standard una lunga indicata in tabella con la lettera L. Tutte le misure di porta-inserto indicate nella tabella sono sempre disponibili a magazzino.



figura 2
picture 2

GB ONE CUTTING EDGE INSERT HOLDER FOR CNC MACHINES

The insert holder is made in hardened and quenched steel; these treatments assure a great resistance to compression.

The insert holder (UT) is available with two cylindrical connection to the machine tool: 25mm and 32 mm. For each connection two machining length are available: a standard length and a long one, indicated in the table with the letter "L". All insert holder sizes indicated in the table are always available in stock.

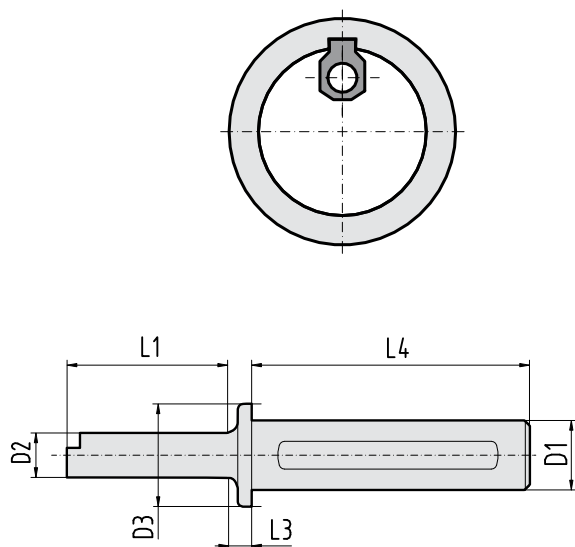
| ARTICOLO-ITEM (material) | GAMBO SHANK | L1 (mm) | L3 (mm) | L4 (mm) | D1 (mm) | D2 (mm) | D3 (mm) | foro minimo- minimum hole (mm) |
|-----------------------------|----------------|------------|------------|------------|------------|------------|------------|--------------------------------------|
| HARDENED | | | | | | | | |
| UT-02 | 25 | 25 | 9 | 90 | 25 | 6 | 30 | 7 |
| | 25-L | 34,5 | | 100 | 32 | | | |
| | 32 | 25 | | 100 | 32 | | 37 | |
| | 32-L | 34,5 | | | | | | |
| UT-03 | 25 | 30 | 9 | 90 | 25 | 8 | 30 | 8,7 |
| | 25-L | 40 | | 100 | 32 | | 37 | |
| | 32 | 30 | | | | | 100 | |
| | 32-L | 40 | | | | | | |
| UT-04 | 25 | 40 | 9 | 90 | 25 | 10 | 30 | 11 |
| | 25-L | 56 | | 100 | 32 | | 37 | |
| | 32 | 40 | | | | | 100 | |
| | 32-L | 56 | | | | | | |
| UT-05 | 25 | 46 | 9 | 90 | 25 | 12 | 30 | 13 |
| | 25-L | 66 | | 100 | 32 | | 37 | |
| | 32 | 46 | | | | | 100 | |
| | 32-L | 66 | | | | | | |
| UT-06 | 25 | 56 | 9 | 90 | 25 | 16 | 30 | 17 |
| | 25-L | 81 | | 100 | 32 | | 37 | |
| | 32 | 56 | | | | | 100 | |
| | 32-L | 81 | | | | | | |
| UT-08 | 25 | 68 | 9 | 90 | 25 | 20 | 30 | 21,5 |
| | 25-L | 100 | | 100 | 32 | | 37 | |
| | 32 | 68 | | | | | 100 | |
| | 32-L | 100 | | | | | | |
| UT-10 | 25 | 86 | 9 | 90 | 25 | 25 | 32 | 28 |
| | 25-L | 126 | | 100 | 32 | | 37 | |
| | 32 | 86 | | | | | 100 | |
| | 32-L | 126 | | | | | | |
| UT-12 | 25 | 104 | 9 | 90 | 25 | 30 | 35 | 32 |
| | 25-L | 161 | | 100 | 32 | | 37 | |
| | 32 | 104 | | | | | 100 | |
| | 32-L | 161 | | | | | | |
| UT-14/16 | 25 | 126 | 9 | 90 | 25 | 35 | 37 | 37 |
| | 25-L | 180 | | 100 | 32 | | 37 | |
| | 32 | 126 | | | | | 100 | |
| | 32-L | 180 | | | | | | |
| UT-18/25 | 32 | 140 | 9 | 100 | 32 | 40 | 45 | 45 |
| | 32-L | 200 | | | | | | |



I INSERTI PER PROFILI QUADRI INTERNI

Questa serie di utensili serve per la realizzazione di quadri interni. Ciascun inserto può realizzare quadri di dimensioni diverse (es: l'inserto IN-SQ-27/37 può realizzare quadri dal 27 al 37mm). La misura del preforo deve avere un diametro pari al 5% in più della misura del quadro.

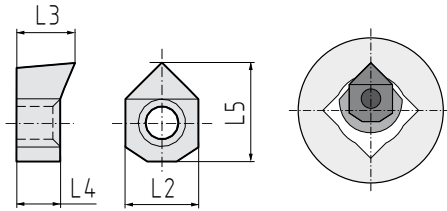

GB INSERTS FOR INTERNAL SQUARE PROFILES

This series of tools is used to produce internal squares. Each insert can make squares of different sizes (e.g. insert IN-SQ-27/37 can make squares from 27 to 37mm A/F). The size of the bore must have a diameter 5% bigger than the size of the square.

| ARTICOLO-ITEM (materiale - material) | AREA DI LAVORO WORKING ARE | | L2 (mm) | L3 (mm) | L4 (mm) | L5 (mm) | UT | |
|---|-------------------------------|----|------------|------------|------------|------------|------|-------------|
| | SINTERIZ. | mm | | | | | | inches |
| IN-SQ-08/10 | min | 8 | 0,314 | 6,08 | 7 | 5 | 7 | UT-SQ-08/10 |
| | max | 10 | 0,393 | | | | | |
| IN-SQ-10/13 | min | 10 | 0,393 | 6,08 | 7 | 5 | 7,5 | UT-SQ-10/13 |
| | max | 13 | 0,511 | | | | | |
| IN-SQ-13/16 | min | 13 | 0,511 | 10,08 | 8 | 6 | 12 | UT-SQ-13/16 |
| | max | 16 | 0,629 | | | | | |
| IN-SQ-16/19 | min | 16 | 0,629 | 10,08 | 8 | 6 | 12,5 | UT-SQ-16/19 |
| | max | 19 | 0,748 | | | | | |
| IN-SQ-19/27 | min | 19 | 0,748 | 13,1 | 13 | 10 | 17 | UT-SQ-19/27 |
| | max | 27 | 1,062 | | | | | |
| IN-SQ-27/37 | min | 27 | 1,062 | 18 | 14 | 10 | 22 | UT-SQ-27/37 |
| | max | 37 | 1,456 | | | | | |
| IN-SQ-37/50 | min | 37 | 1,456 | 26 | 18 | 10 | 30 | UT-SQ-37/50 |
| | max | 50 | 1,968 | | | | | |

I PORTA-INSERTO PER PROFILI QUADRI INTERNI

È realizzato in acciaio bonificato e temprato: in questo modo viene garantita una ottima resistenza alla compressione.

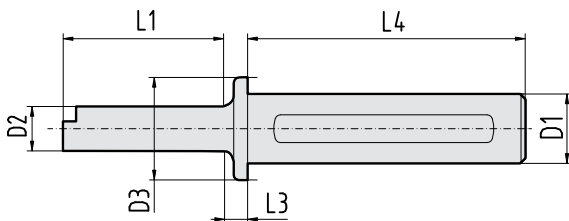

GB INSERT HOLDER FOR INTERNAL SQUARE PROFILES

The insert holder is made in hardened and quenched steel: these treatments assure a great resistance to compression.

| ARTICOLO-ITEM (materiale - material) | GAMBO SHANK | L1 (mm) | L3 (mm) | L4 (mm) | D1 (mm) | D2 (mm) | D3 (mm) | foro minimo - minimum hole (mm) |
|---|----------------|------------|------------|------------|------------|------------|------------|---------------------------------------|
| UT-SQ-08/10 | 25 | 30 | 9 | 90 | 25 | 7,25 | 30 | 8 |
| | 32 | | | 100 | 32 | | 38 | |
| UT-SQ-10/13 | 25 | 40 | 9 | 90 | 25 | 8,6 | 30 | 10 |
| | 32 | | | 100 | 32 | | 38 | |
| UT-SQ-13/16 | 25 | 50 | 9 | 90 | 25 | 12 | 30 | 13 |
| | 32 | | | 100 | 32 | | 38 | |
| UT-SQ-16/19 | 25 | 52 | 9 | 90 | 25 | 15 | 30 | 16 |
| | 32 | | | 100 | 32 | | 38 | |
| UT-SQ-19/27 | 25 | 86 | 9 | 90 | 25 | 18,50 | 30 | 19 |
| | 32 | | | 100 | 32 | | 38 | |
| UT-SQ-27/37 | 25 | 100 | 9 | 90 | 25 | 25 | 30 | 27 |
| | 32 | | | 100 | 32 | | 38 | |
| UT-SQ-37/50 | 32 | 140 | 9 | 100 | 32 | 35 | 45 | 27 |

Per materiali particolarmente tenaci (HRC>30) possiamo fornire inserti e porta-inserti per realizzare figure quadre di dimensioni più piccole.

For particularly hard materials (HRC > 30) we can supply inserts and insert holders to make squares of smaller dimensions.

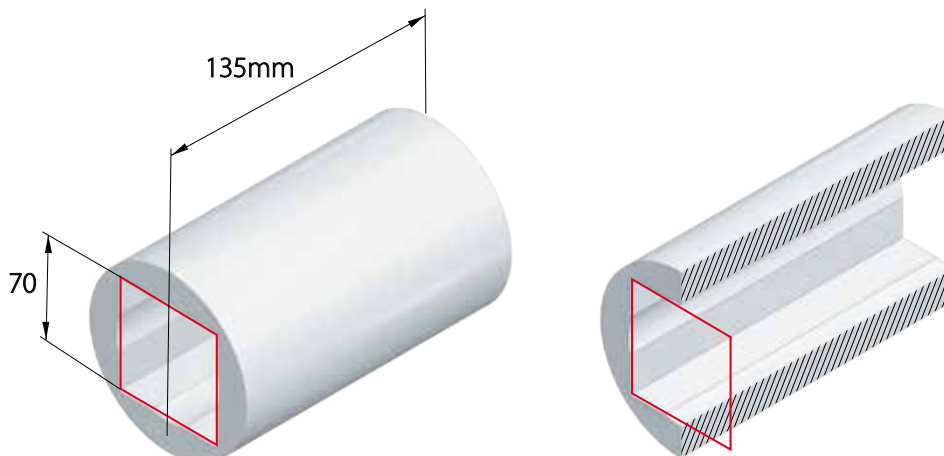



I INSERTI PER PROFILI ESAGONALI INTERNI

Questa serie di utensili serve per la realizzazione di esagoni interni. Ciascun inserto può realizzare esagoni di dimensioni diverse (es: l'inserto IN-HEX-28/37 può realizzare esagoni dal 28 al 37mm). La misura del preforo deve avere un diametro pari al 2% in più della misura dell'esagono.

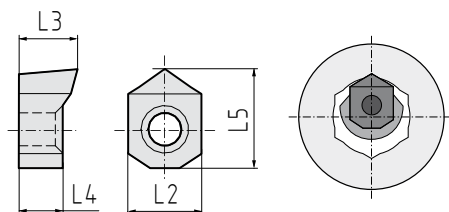

GB INSERTS FOR INTERNAL HEXAGONAL PROFILES

This series of tools is used to produce internal hexagons. Each insert can make hexagons of different sizes (e.g. insert IN-HEX-28/37 can produce hexagons from 28 to 37mm A/F). The size of the bore must have a diameter 2% bigger than the size of the hexagon.

| ARTICOLO-ITEM (materiale - material) | AREA DI LAVORO WORKING ARE | | L2 (mm) | L3 (mm) | L4 (mm) | L5 (mm) | UT | |
|---|-------------------------------|----|------------|------------|------------|------------|------|--------------|
| | SINTERIZ. | mm | | | | | | inches |
| IN-HEX-09/11 | min | 9 | 0,354 | 6,08 | 7 | 5 | 7,5 | UT-HEX-09/11 |
| | max | 11 | 0,433 | | | | | |
| IN-HEX-11/17 | min | 11 | 0,433 | 6,08 | 7 | 5 | 8 | UT-HEX-11/17 |
| | max | 17 | 0,669 | | | | | |
| IN-HEX-17/28 | min | 17 | 0,669 | 10,08 | 9 | 6 | 13,5 | UT-HEX-17/28 |
| | max | 28 | 1,102 | | | | | |
| IN-HEX-28/37 | min | 28 | 1,102 | 13,1 | 14 | 10 | 18,5 | UT-HEX-28/37 |
| | max | 37 | 1,456 | | | | | |
| IN-HEX-37/45 | min | 37 | 1,456 | 18 | 14 | 10 | 22 | UT-HEX-37/45 |
| | max | 45 | 1,771 | | | | | |
| IN-HEX-45/70 | min | 45 | 1,771 | 26 | 16 | 10 | 30 | UT-HEX-45/70 |
| | max | 70 | 2,755 | | | | | |

I PORTA-INSERTO PER PROFILI ESAGONALI INTERNI

È realizzato in acciaio bonificato e temprato: in questo modo viene garantita una ottima resistenza alla compressione.

GB INSERT HOLDER FOR INTERNAL HEXAGONAL PROFILES

The insert holder is made in hardened and quenched steel: these treatments assure a great resistance to compression.

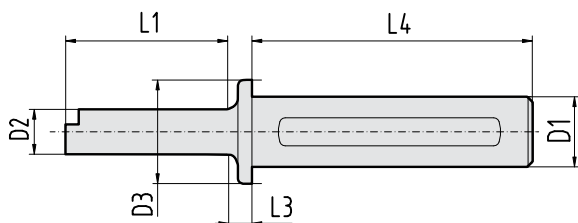

| ARTICOLO - ITEM (materiale - material) | GAMBO SHANK | L1 (mm) | L3 (mm) | L4 (mm) | D1 (mm) | D2 (mm) | D3 (mm) | foro minimo - minimum hole (mm) |
|---|----------------|------------|------------|------------|------------|------------|------------|---------------------------------------|
| | | | | | | | | |
| UT-HEX-09/11 | 25 | 30 | 9 | 90 | 25 | 8 | 30 | 9 |
| | 32 | | | 100 | 32 | | 38 | |
| UT-HEX-11/17 | 25 | 40 | 9 | 90 | 25 | 10 | 30 | 11 |
| | 32 | | | 100 | 32 | | 38 | |
| UT-HEX-17/28 | 25 | 56 | 9 | 90 | 25 | 15 | 30 | 17 |
| | 32 | | | 100 | 32 | | 38 | |
| UT-HEX-28/37 | 25 | 86 | 9 | 90 | 25 | 25 | 30 | 28 |
| | 32 | | | 100 | 32 | | 38 | |
| UT-HEX-37/45 | 25 | 126 | 9 | 90 | 25 | 35 | 45 | 37 |
| | 32 | | | 100 | 32 | | 45 | |
| UT-HEX-45/70 | 32 | 140 | 9 | 100 | 32 | 37 | 45 | 45 |

Per materiali particolarmente tenaci (HRC>30) possiamo fornire anche inserti e porta-inserti per realizzare figure esagonali di dimensioni più piccole.

For particularly hard materials (HRC > 30) we can supply inserts and insert holders to make hexagons of smaller dimensions.

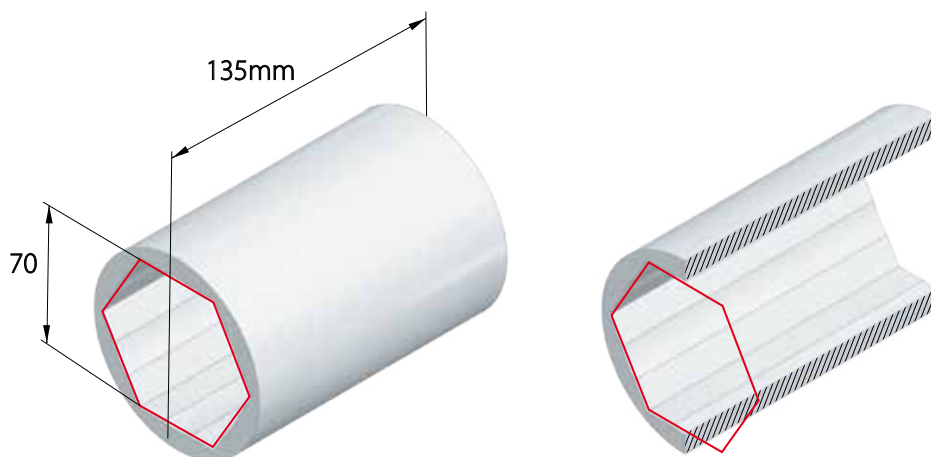



I UTENSILI PER PROFILI SCANALATI

La linea di utensili UTS è stata ideata per consentire la realizzazione di profili interni scanalati. Sono disponibili a stock dal tipo UTS-02 al tipo UTS-18/25.

La scelta dell'utensile sarà determinata dal foro minimo di entrata del pezzo da lavorare. Sugeriamo, infatti, di acquistare l'utensile con il diametro (D2) più vicino al valore di tale foro, come indicato nella tabella. E' possibile, inoltre, realizzare utensili speciali, di vario diametro e misura, in base alle specifiche esigenze del cliente.

Gli inserti da utilizzare sulla linea di utensili UTS per profili scanalati sono tutti considerati speciali: non sono disponibili a magazzino, ma vengono prodotti appositamente per il cliente in base alla lavorazione che deve effettuare.

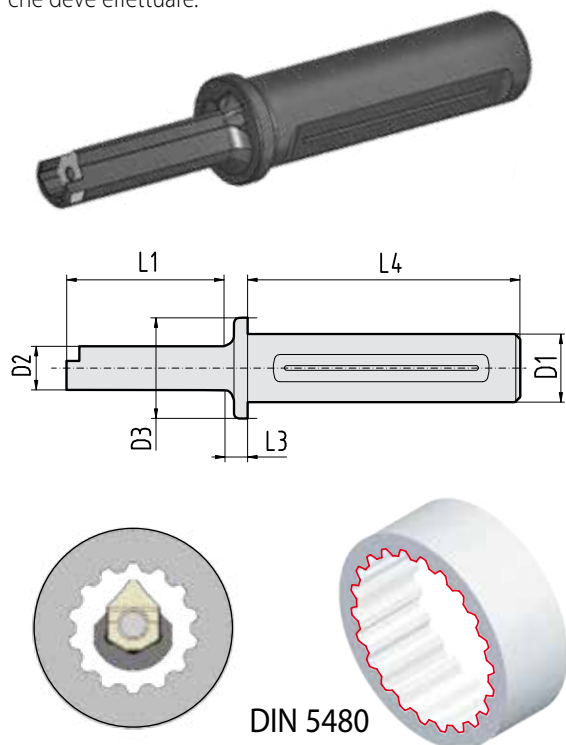

DIN 5480

GB TOOLS FOR SPLINED PROFILES

The UTS tool line was designed to make splined internal profiles. They are in stock from the UTS-02 type through the UTS-18/25 type.

The choice of tool is determined by the minimum entry hole of the workpiece to be machined. In fact, we recommend purchasing a tool with a diameter (D2) as close to the value of said hole as possible, as shown in the table.

It is also possible to make special tools in various diameters and sizes based on specific customer needs.

Inserts used on the UTS tool line for splined profiles are all considered special: they are not in stock; rather they are manufactured specifically for the customer based on the type of machining required.

| ARTICOLO-ITEM (material) | GAMBO SHANK | L1 (mm) | L3 (mm) | L4 (mm) | D1 (mm) | D2 (mm) | D3 (mm) | foro minimo - minimum hole (mm) |
|-----------------------------|----------------|------------|------------|------------|------------|------------|------------|---------------------------------------|
| UTS-02 | 25 | 25 | 9 | 90 | 25 | 6,5 | 30 | 7 |
| | 32 | 25 | | 100 | 32 | | 37 | |
| UTS-03 | 25 | 30 | 9 | 90 | 25 | 7,8 | 30 | 8,5 |
| | 32 | 30 | | 100 | 32 | | 37 | |
| UTS-04 | 25 | 40 | 9 | 90 | 25 | 10 | 30 | 10,5 |
| | 32 | 40 | | 100 | 32 | | 37 | |
| UTS-05 | 25 | 46 | 9 | 90 | 25 | 12 | 30 | 12,5 |
| | 32 | 46 | | 100 | 32 | | 37 | |
| UTS-06 | 25 | 56 | 9 | 90 | 25 | 16 | 30 | 16,5 |
| | 32 | 56 | | 100 | 32 | | 37 | |
| UTS-08 | 25 | 68 | 9 | 90 | 25 | 20 | 30 | 21 |
| | 32 | 68 | | 100 | 32 | | 37 | |
| UTS-10 | 25 | 86 | 9 | 90 | 25 | 25 | 30 | 28 |
| | 32 | 86 | | 100 | 32 | | 37 | |
| UTS-12 | 25 | 104 | 9 | 90 | 25 | 30 | 30 | 33 |
| | 32 | 104 | | 100 | 32 | | 37 | |
| UTS-14/16 | 25 | 126 | 9 | 90 | 25 | 35 | 37 | 38 |
| | 32 | 126 | | 100 | 32 | | 37 | |
| UTS-18/25 | 32 | 140 | 9 | 100 | 32 | 40 | 45 | 42 |

I PORTA-INSERTO PER PROFILI ESTERNI (UTE DX - UTE SX)

Tutte le volte che il pezzo da brocciare necessita di essere preso anche con la contropunta, le scanalature esterne si possono realizzare con un porta inserto specifico (UTE).

Due sono le versioni (fig.3):

- Porta-inserto per brocciature esterne destro (UTE DX)
- Porta-inserto per brocciature esterne sinistro (UTE SX)



figura 3
picture 3

GB INSERT HOLDER FOR EXTERNAL PROFILES (UTE DX - UTE SX)

Anytime it is necessary to hold the part with the tailstock too, external machinings can be produced using a specific insert holder (UTE).

Two versions are available (fig.3):

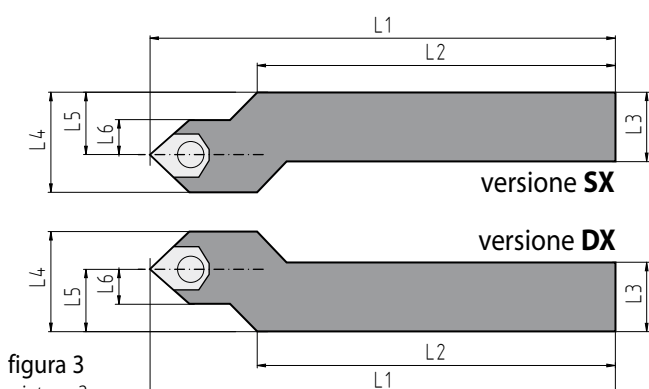
- Insert holder for external machinings right (UTE DX)
- Insert holder for external machinings left (UTE SX)

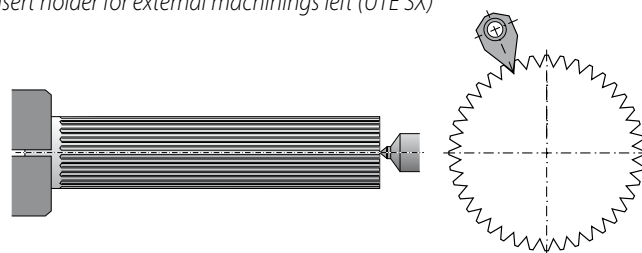

| ARTICOLO-ITEM (materiale - material) | L1 (mm) | L2 (mm) | L3 (mm) | L4 (mm) | L5 (mm) | L6 (mm) |
|---|------------|------------|------------|------------|------------|------------|
| HARDENED | | | | | | |
| UTE 20-DX | 150 | 110 | 20x20 | 32,50 | 20 | 12,5 |
| UTE 20-SX | 150 | 110 | 20x20 | 32,50 | 20 | 12,5 |
| UTE 25-DX | 150 | 110 | 25x25 | 37,50 | 25 | 12,5 |
| UTE 25-SX | 150 | 110 | 25x25 | 37,50 | 25 | 12,5 |



I BUSSOLE ECCENTRICHE (B)

Rappresenta il cuore del sistema BTA di brocciatura di chiavette per tutti i torni CNC che non dispongono dell'asse Y. Grazie alla scala graduata, impressa sul collare della bussola, è possibile intervenire per correggere errori di simmetria che possono presentarsi all'inizio della lavorazione di brocciatura. Con lo spostamento del foro interno rispetto all'asse centrale della bussola (0,5mm), il campo di correzione del porta-inserto varia da +0,5mm a -0,5mm.

Lo spostamento di una sola tacca, sulla scala graduata, produce uno spostamento dell'inserto di 0,03 mm. La bussola è realizzata in acciaio per utensili, temprata e rettificata. La bussola viene costruita con diametro esterno di mm B-32 / B-40 / B-50 (con tolleranza H7).

A richiesta possiamo fornire la stessa bussola con attacco VDI.

Sul principio della regolazione di concentricità della bussola eccentrica è stata chiesta e ottenuta la registrazione brevettuale.

Abbiamo 2 versioni di bussola eccentrica: misure in mm e il pollici.

Per facilitare l'individuazione del sistema BT/BTA necessario per costruire, ad esempio, una chiavetta di mm 4 con tolleranza H7 e lunghezza 35 mm, si procede nel modo seguente:

> Tipo di inserto L1=4 il codice è IN-4H7

> Tipo di porta inserto: il codice è UT-4-32 o UT-4-25

e per il sistema BTA:

> Tipo di bussola: il codice è B-40 o B-32 rispettivamente

GB ECCENTRIC BUSH (B)

It's the main innovation the BTA system brings in the broaching machining of keyways with CNC machine tools without Y axis. Thanks to its graduated scale engraved in the collar it's possible to correct every symmetry mistake may be occurred during the keyway machining. Thanks to the shift of the inside hole as to the bush central axis (0,5 mm) the insert holder field of action goes from +0,5 mm to -0,5 mm.

Every notch on the graduated scale corresponds to a 0,03 mm turn of the insert. The bush is made in hardened steel for tools and grinded. The available outside diameters for the bush are: 32 mm, 40 mm and 50 mm (with H7 tolerance).

By Customer's request BRIGHETTI MECCANICA SRL can supply this bush with a VDI connection or sizes in inches.

This adjustable graduated bush is covered by regular patent.

To help finding the correct tools for a machining, let's make the example of a 4 mm keyway, 35 mm long with a H7 tolerance:

> Insert with L1=4; the code is IN-4-H7

> Insert holder: the code is UT-4-32 or UT-4-25

if the eccentric bush is necessary:

> The code for the bush is B-40 or B-32 respectively



| ARTICOLO ITEM | Ø D1 (H7) (mm) | L1 (mm) | L2 (mm) | L3 (mm) | L4 (mm) | L5 (mm) | D2 (mm) | D3 (mm) |
|---------------|----------------|---------|---------|---------|---------|---------|---------|---------|
| B-32 | 32 | 85 | 70 | 58 | 15 | 20 | 48 | 25 |
| B-40 | 40 | 95 | 80 | 66 | 15 | 20 | 55 | 32 |
| B-50 | 50 | 115 | 100 | 75 | 15 | 20 | 65 | 32 |
| B-60 | 60 | 115 | 100 | 75 | 15 | 20 | 80 | 32 |

A richiesta sono disponibili le bussole eccentriche con attacco VDI

Eccentric bushes with VDI connection are available on request

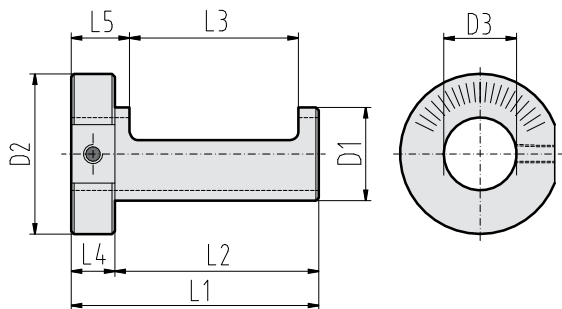



I ALLINEATORI PER FRESATRICI

Gli allineatori vengono utilizzati su centri di lavoro e su macchine fresatrici al fine di assicurare il corretto montaggio dell'utensile sulla macchina CNC.

Il montaggio consiste nell'avvitare il piattino nella stessa posizione dell'inserto. Grazie alla forma del piattino, dotato di un piano rettilineo, è possibile effettuare, con strumenti di controllo quali il tastatore o il comparatore, un fissaggio corretto del BT/BTA rispetto agli assi di riferimento del pezzo da brocciare. Sono prodotti in cinque misure diverse a seconda del tipo di porta-inserto:

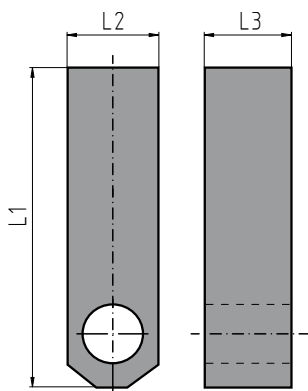

| ARTICOLO ITEM | L1 (mm) | L2 (mm) | L3 (mm) | Utensili - Tools |
|------------------|------------|------------|------------|---------------------------------|
| PN-0 | 5 | 50 | 6 | UT/UTS-02 |
| PN-1 | 6 | 50 | 8 | UT/UTS-03, UT/UTS-04, UT/UTS-05 |
| PN-2 | 10 | 50 | 8 | UT/UTS-06, UT/UTS-08 |
| PN-3 | 13 | 60 | 10 | UT/UTS-10, UT/UTS-12 |
| PN-4 | 18 | 70 | 10 | UT/UTS-14/16 |
| PN-5 | 26 | 70 | 10 | UT/UTS-18/25 |

GB ALIGNMENT PLATES FOR MILLING MACHINES

Alignment plates are used to assure the correct concentricity between the tools and the piece on a machining center.

The alignment plate is installed on the holder in the insert-seat; thanks to its shape, it is possible to check the correct alignment between the BT/BTA and the reference axes, with a simple gauge or a comparator. Alignment plates are available in five different sizes, each suitable for one particular insert holder:

I FLESSIBILITÀ DEL SISTEMA E TEMPI DI ESECUZIONE LAVORO

La possibilità di applicare inserti delle più diverse misure e forme consente di ottenere profili interni che altrimenti non sarebbe possibile se non a costi elevati.

Si sottolinea che la velocità di taglio e l'incremento per ogni corsa dipendono essenzialmente dal tipo di materiale da lavorare.

Quando non esistono esigenze di produzione di quantità elevate il sistema BT/BTA è particolarmente indicato per eseguire dentature interne a denti evolventi.

GB SYSTEM FLEXIBILITY AND MACHINING TIME

The chance to produce inserts with the most different shapes makes it possible to machine inner profiles which can otherwise obtained only at high costs.

It is understood that the cutting speed and the cutting increase at every hit depend on the kind of material to machine.

When a high quantity production is not required the BT/BTA system can be used to machine inner splines and involute splines.

I PROGRAMMAZIONE MACCHINA CNC

A richiesta possiamo fornire gratuitamente i programmi macchina sulle principali macchine utensili che utilizzano i più diffusi controlli CNC.

I programmi sono strutturati in modo che alcuni parametri di lavorazione sono lasciati disponibili all'operatore della macchina.

GB CNC MACHINE TOOL PROGRAMMING

On demand, we can provide free machine programs on the main machine tools, using the most popular CNC controls.

The programs are structured so that some processing parameters are left available to the machine operator.



I VELOCITÀ DI TAGLIO E INCREMENTO DI TAGLIO DA UN PASSAGGIO AL SUCCESSIVO

Di seguito diamo alcune indicazioni relativamente ai seguenti parametri in relazione al materiale da lavorare.

GB CUTTING SPEED AND CUTTING INCREASE HIT BY HIT

Down below there are our suggestions about machining parameters with regards to the material to machine.

Legenda:

f = avanzamento (mm)

asportazione (mm)

Legend:

f = advancement (mm)

chip removal (mm)

| PARAMETRI DI UTILIZZO PER TIPOLOGIA DI INSERTO / USAGE PARAMETERS BY TYPES OF INSERT | | | MATERIALE DA LAVORARE / MATERIAL TO WORK | | | | | | | |
|--|--|---|--|------------------------------------|-------------------------------------|---|------------------------------------|------------------------------------|------------------------------------|------|
| | | | alluminio / aluminum | acciaio / steel | acciaio / steel | acciaio inox / stainless steel | ghisa / cast iron | rame / copper | ottone / brass | |
| | | | Rm <500 (N/mm ²) | Rm <600 (N/mm ²) | Rm <1400 (N/mm ²) | Rm >900 (N/mm ²) | Rm <600 (N/mm ²) | Rm <350 (N/mm ²) | Rm <350 (N/mm ²) | |
| codice/code: IN inserti per sede chiavetta <i>inserts for internal keyway (mm)</i> | codice/code: IN-SQ inserti per quadro interno <i>inserts for internal square profiles (mm)</i> | codice/code: IN-HEX inserti per esagono interno <i>inserts for internal hexagonal profiles (mm)</i> | f | 8000 | 10000 | 6000 | 5000 | 5000 | 8000 | 7000 |
| 2 - 5 | 8 - 10 | 9 - 11 | asportazione (mm) / chip removal (mm) | 0,20 | 0,18 | 0,08 | 0,05 | 0,13 | 0,18 | 0,10 |
| 6 | 10 - 13 | 11 - 17 | | 0,18 | 0,15 | 0,07 | 0,04 | 0,11 | 0,15 | 0,09 |
| 8 | 13 - 16 | 17 - 28 | | 0,15 | 0,14 | 0,06 | 0,04 | 0,10 | 0,15 | 0,08 |
| 10 | 16 - 19 | - | | 0,14 | 0,12 | 0,05 | 0,04 | 0,09 | 0,12 | 0,07 |
| 12 | 19 - 27 | 28 - 37 | | 0,12 | 0,10 | 0,05 | 0,03 | 0,08 | 0,11 | 0,06 |
| 14 - 16 | 27 - 37 | 37 - 45 | | 0,10 | 0,08 | 0,04 | 0,03 | 0,07 | 0,10 | 0,05 |
| 18 | - | - | | 0,07 | 0,06 | 0,03 | 0,02 | 0,05 | 0,08 | 0,03 |
| 20 - 25 | 37 - 50 | 45-70 | | 0,04 | 0,04 | 0,02 | 0,02 | 0,03 | 0,04 | 0,02 |



Utensile per interno: MINITOOL

Tool for interior: MINITOOL

I La Brighetti Meccanica, per andare in contro alle necessità di lavorazioni di componenti sempre più piccoli, ha sviluppato la linea **MINITOOL**.

Questa linea prevede l'utilizzo di inserti integrali che permettono di ottenere profili di taglio estremamente piccoli e dalle geometrie più varie. Al fine di assicurare un'elevata rigidità degli utensili ed ottenere utensili assolutamente perfetti per l'operazione che si deve eseguire, gli inserti integrali vengono realizzati secondo le richieste del cliente in base alle proprie specifiche esigenze.

Gli inserti della serie MINITOOL si possono alloggiare nel relativo portainsero UT-1/8-25 o, in alternativa, nel portainsero UT-1/8-32. I suddetti portainseri, a loro volta, si possono montare all'interno delle boccole eccentriche e, in questo modo, si potranno correggere gli eventuali errori di simmetria sui torni CNC che non dispongono di asse Y.

In alternativa, gli inserti MINITOOL si possono bloccare nel portautensile della macchina con una semplice pinza di fissaggio (ad es. una pinza ER). In questo caso è preferibile che la macchina utensile disponga di asse Y.

L'utensile **PORTA INSERTO** della linea MINITOOL è costruito in modo tale da consentire il rapido inserimento dell'inserto integrale e da alloggiare lo stesso con estrema precisione.

È disponibile in due versioni: con diametro di presa 25 mm e 32 mm.

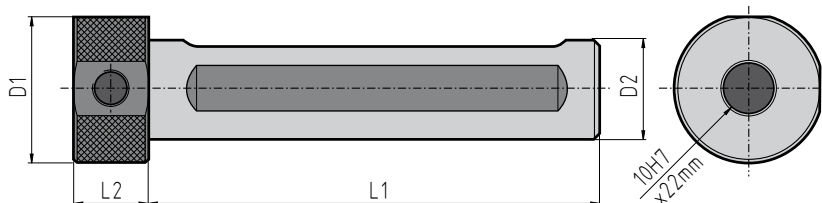

Gli **INSERTI INTEGRALI** della linea MINITOOL presentano una parte piana sul collare diametro 15 mm che permette all'operatore di controllare in tempi molto brevi la corretta posizione dell'inserto mediante l'utilizzo di un comune comparatore o tastatore. Sono realizzabili in due leghe: acciaio sinterizzato o widia ad alta tenacità.

La durata degli inserti è molto lunga ed è possibile eseguire molte riaffilature prima di dover sostituire l'inserto.

Il tipo di affilatura e di rivestimento andranno valutati in considerazione del tipo di materiale che occorre lavorare. Gli inserti integrali si possono alloggiare nel portainsero UT-1/8-25 o UT-1/8-32.

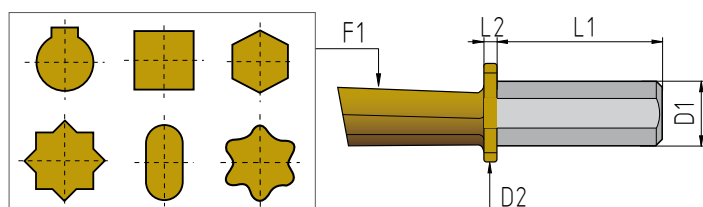

GB Brighetti Meccanica, to accommodate the need for machining increasingly smaller components, developed the **MINITOOL** line.

This line envisages the use of integral inserts that allow extremely small cut profiles to be obtained, with the most diverse geometries.

In order to ensure a high rigidity of the tools and to obtain absolutely perfect tools for the desired operation, the integral inserts are created according to client requests, taking into account all specific needs.

The MINITOOL series inserts can be housed in the relative insert holder UT-1/8-25 or, as an alternative, in insert holder UT-1/8-32.

The above insert holders, in turn, can be mounted inside eccentric bushes and, in this way, eventual errors in the symmetry on CNC lathes that do not have a Y axis, can be corrected.

On the other hand, MINITOOL inserts can be blocked in the machine's tool holder with a simple mounting clamp (e.g. an ER plier).

In this case, it is preferable for the machine tool to be equipped with a Y axis.

The **INSERT HOLDER** tool of the MINITOOL line is constructed in a way that allows the integral insert to be mounted swiftly and to be housed with extreme precision.

It is available in two versions: with 25 mm and 32 mm diameter fastenings.

| ARTICOLO - ITEM | L1 (mm) | L2 (mm) | D1 (mm) | D2 (mm) |
|---------------------|---------|---------|---------|---------|
| UT-1/8-19.05 | 90 | 15 | 30 | 19,05 |
| UT-1/8-20 | 90 | 15 | 30 | 20 |
| UT-1/8-25 | 90 | 15 | 30 | 25 |
| UT-1/8-32 | 100 | 15 | 38 | 32 |

The **INTEGRAL INSERTS** of the MINITOOL line present a flat part on the 15 mm diameter collar, which allows the operator to control the correct position of the insert very swiftly by using a common dial gauge or feeler. These can be made in two alloys: sintered steel or high tenacity carbide.

The inserts have a very lengthy duration and can be re-ground frequently before having to be replaced.

The type of grinding and coating must be assessed by considering the type of material to be processed. Integral inserts can be housed in insert holder UT-1/8-25 or UT-1/8-32.

| ARTICOLO - ITEM | L1 (mm) | L2 (mm) | F1 (mm) | D1 (mm) | D2 (mm) |
|-----------------|---------|---------|---------------------------|---------|---------|
| IN-1/8 | 18 | 2 | a richiesta on request | 10 H7 | 15 |



Utensili per MACCHINE STOZZATRICI

Tools for SLOTTING MACHINES

I ADATTATORI PER MACCHINE STOZZATRICI

Il sistema BT può essere utilizzato anche sulle macchine stozzatrici con l'ausilio di un adattatore.

Le diverse tipologie di adattatori sono dotate di due fori filettati entro i quali vengono avvitate due viti senza testa e a punta piana (M12x8) e servono per fissare l'utensile all'interno degli adattatori stessi. La spina di fresatura (L4xL5) serve a garantire il perfetto allineamento dell'utensile rispetto all'asse di lavoro.

Due sono i tipi di adattatori:

- 1) Adattatore quadro (AD) prodotto in tre misure diverse (L3) (fig.4)
- 2) Adattatore prismatico (ADP) prodotto in due misure diverse (L3) (fig.5)

figura 4
picture 4

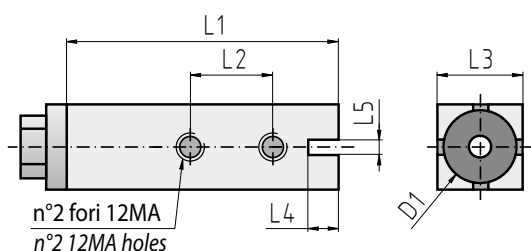

| ARTICOLO ITEM | Misure (mm) / Peso (gr) - Size (mm) / Weight (gr) | | | | | | | | |
|------------------|---|----|----|----|----|----|----|----|------|
| | L1 | L2 | L3 | L4 | L5 | L6 | L7 | D1 | Peso |
| AD-35 | 140 | 40 | 35 | 10 | 6 | / | / | 25 | 500 |
| AD-40 | 140 | 50 | 40 | 10 | 6 | / | / | 32 | 600 |
| AD-50 | 170 | 50 | 50 | 10 | 6 | / | / | 32 | 2200 |

GB ADAPTORS FOR SLOTTING MACHINES

Thanks to an adaptor, BT system is suitable for slotting machines as well.

Insert holders are fastened inside the adaptors by two M12x8 screws.

The timing pin (L4xL5) assures the perfect alignment between the holder and the machining axis.

Adaptors are available in two different models:

- 1) Square adaptor (AD) available in three sizes (L3) (pic.4)
- 2) Prismatic adaptor (ADP) available in two sizes (L3) (pic.5)

figura 5
picture 5

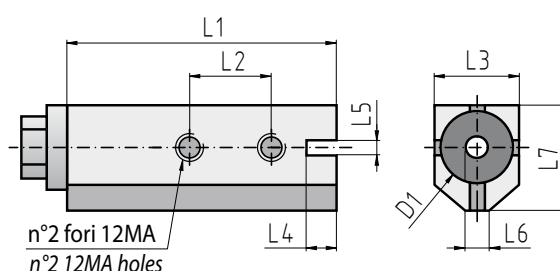

| ARTICOLO ITEM | Misure (mm) / Peso (gr) - Size (mm) / Weight (gr) | | | | | | | | |
|------------------|---|----|----|----|----|----|------|----|-----|
| | L1 | L2 | L3 | L4 | L5 | L6 | L7 | D1 | gr |
| ADP-35 | 140 | 40 | 35 | 10 | 6 | 10 | 41,5 | 25 | 600 |
| ADP-40 | 140 | 50 | 40 | 10 | 6 | 10 | 50 | 32 | 700 |

I PORTA INSERTI MONOTAGLIANTI PER MACCHINE STOZZATRICI

GB ONE CUTTING EDGE HOLDER FOR SLOTTING MACHINES

INSERTO
INHMM / IN

INSERT
INHMM / IN

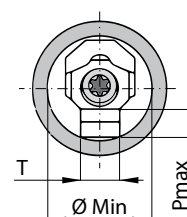
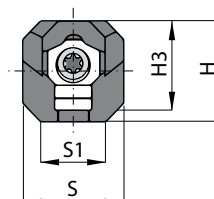
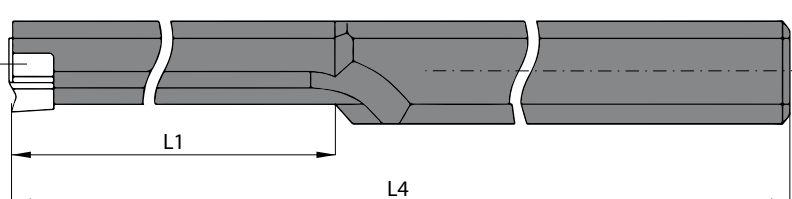

| ARTICOLO - ITEM | H (mm) | H3 (mm) | S (mm) | S1 (mm) | L1 (mm) | L4 (mm) | T (mm) | Ø Min (mm) | P max (mm) | INSERTO / INSERT |
|----------------------|--------|---------|--------|---------|---------|---------|--------|------------|------------|---------------------|
| UTSZ-03120 | 11,3 | 9,3 | 11,3 | 8,2 | 35 | 165 | 3 | 9,9 | 2 | INHMM-03120 / IN-03 |
| UTSZ-04/05120 | 11,3 | 10 | 11,3 | 7 | 60 | 200 | 4 | 10,4 | 3 | INHMM-04120 / IN-04 |
| | | | | | | | 5 | 10,8 | 3,2 | INHMM-05120 / IN-05 |
| UTSZ-06/08 | 15,5 | 16,2 | 12 | - | - | 220 | 6 | 17,9 | 4,9 | INHMM-06 / IN-06 |
| | | | | | | | 8 | 18,4 | 5,2 | INHMM-08 / IN-08 |
| UTSZ-10/12 | 20,6 | 21,5 | 14 | - | - | 250 | 10 | 23,8 | 6,2 | INHMM-10 / IN-10 |
| | | | | | | | 12 | 24,2 | 7,2 | INHMM-12 / IN-12 |
| UTSZ-14/16 | 35 | 36 | 30 | - | - | 350 | 14 | 43 | 8,5 | INHMM-14 |
| | | | | | | | 16 | 44 | | INHMM-16 |
| UTSZ-18/20/22 | 45 | 46 | 35 | - | - | 400 | 18 | 53 | 8,5 | INHMM-18 |
| | | | | | | | 20 | 54 | | INHMM-20 |
| | | | | | | | 22 | 55 | | INHMM-22 |

INHMM
METALLO DURO
vedi pag. 69
HARD METAL
see page 69

IN
SINTERIZZATO
vedi pag. 58
SINTERED
see page 58



I INSERTI IN METALLO DURO

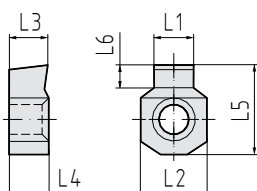

GB HARD METAL INSERTS

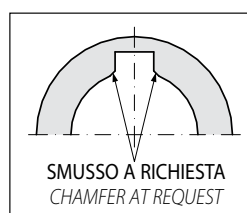

MISURE IN POLLICI
A RICHIESTA

INCHES SIZES
AT REQUEST

misura metrica / metric size

| ARTICOLO ITEM (material) | TOLLER. TOLER. | L1 (mm) | L2 (mm) | L3 (mm) | L4 (mm) | L5 (mm) | L6 (mm) | UT |
|-----------------------------|-------------------|------------|------------|------------|------------|------------|------------|--------------|
| HARD METAL | | | | | | | | |
| INHM-03 | H7 | 3,010 | 6,08 | 4,7 | 4,7 | 7 | 2 | UT-03 |
| | D10 | 3,060 | | | | | | |
| | C11 | 3,120 | | | | | | |
| INHM-04 | H7 | 4,012 | 6,08 | 4,7 | 4,7 | 8 | 3 | UT-04 |
| | D10 | 4,078 | | | | | | |
| | C11 | 4,145 | | | | | | |
| INHM-05 | H7 | 5,012 | 6,08 | 4,7 | 4,7 | 8 | 3,2 | UT-04 |
| | D10 | 5,078 | | | | | | |
| | C11 | 5,145 | | | | | | |
| INHM-06 | H7 | 6,012 | 10,08 | 6,3 | 6,3 | 13,8 | 4,9 | UT-06 |
| | D10 | 6,078 | | | | | | |
| | C11 | 6,145 | | | | | | |
| INHM-08 | H7 | 8,015 | 10,08 | 6,3 | 6,3 | 13,8 | 5,2 | UT-06 |
| | D10 | 8,098 | | | | | | |
| | C11 | 8,170 | | | | | | |
| INHM-10 | H7 | 10,015 | 13,1 | 9,4 | 9,4 | 18,5 | 6,2 | UT-10 |
| | D10 | 10,098 | | | | | | |
| | C11 | 10,170 | | | | | | |

| ARTICOLO ITEM (material) | TOLLER. TOLER. | L1 (mm) | L2 (mm) | L3 (mm) | L4 (mm) | L5 (mm) | L6 (mm) | UT |
|-----------------------------|-------------------|------------|------------|------------|------------|------------|------------|----------------------|
| HARD METAL | | | | | | | | |
| INHM-12 | H7 | 12,018 | 13,1 | 9,4 | 9,4 | 18,5 | 7,2 | UT-12 |
| | D10 | 12,120 | | | | | | |
| | C11 | 12,205 | | | | | | |
| INHM-14 | H7 | 14,018 | 20 | 12,5 | 12,5 | 30,2 | 8,8 | UTSZ-14/16 |
| | D10 | 14,120 | | | | | | |
| | C11 | 14,205 | | | | | | |
| INHM-16 | H7 | 16,018 | 20 | 12,5 | 12,5 | 30,2 | 8,8 | UTSZ-14/16 |
| | D10 | 16,120 | | | | | | |
| | C11 | 16,205 | | | | | | |
| INHM-18 | H7 | 18,018 | 25 | 12,5 | 12,5 | 30,2 | 8,8 | UTSZ-18/20/22 |
| | D10 | 18,120 | | | | | | |
| | C11 | 18,205 | | | | | | |
| INHM-20 | H7 | 20,021 | 25 | 12,5 | 12,5 | 30,2 | 8,8 | UTSZ-18/20/22 |
| | D10 | 20,149 | | | | | | |
| | C11 | 20,240 | | | | | | |
| INHM-22 | H7 | 22,021 | 25 | 12,5 | 12,5 | 30,2 | 8,8 | UTSZ-18/20/22 |
| | D10 | 22,149 | | | | | | |
| | C11 | 22,240 | | | | | | |

segue / continued >>

I INSERTI DOPPIO TAGLIENTE

GB DOUBLE CUTTING EDGE INSERTS



| ARTICOLO - ITEM (materiale - material) | TOLLER. TOLER. | T (mm) | L (mm) | Ød (mm) |
|---|-------------------|-----------|-----------|------------|
| SINTERIZ. | | | | |
| INDC-0404 | H7 | 4,012 | 11 | 4 |
| | C11 | 4,145 | | |
| INDC-0505 | H7 | 5,012 | 12 | 5 |
| | C11 | 5,145 | | |
| INDC-0606 | H7 | 6,012 | 18 | 6 |
| | C11 | 6,145 | | |
| INDC-0808 | H7 | 8,015 | 21 | 8 |
| | C11 | 8,170 | | |
| INDC-1010 | H7 | 10,015 | 30 | 10 |
| | C11 | 10,170 | | |
| INDC-1212 | H7 | 12,018 | 38 | 12 |
| | C11 | 12,205 | | |

| ARTICOLO - ITEM (materiale - material) | TOLLER. TOLER. | T (mm) | L (mm) | Ød (mm) |
|---|-------------------|-----------|-----------|------------|
| SINTERIZ. | | | | |
| INDC-1414 | H7 | 14,018 | 40 | 14 |
| | C11 | 14,205 | | |
| INDC-1616 | H7 | 16,018 | 45 | 16 |
| | C11 | 16,205 | | |
| INDC-1818 | H7 | 18,018 | 55 | 18 |
| | C11 | 18,205 | | |
| INDC-2020 | H7 | 20,021 | 65 | 20 |
| | C11 | 20,240 | | |
| INDC-2222 | H7 | 22,021 | 65 | 20 |
| | C11 | 22,240 | | |

segue / continued >>

I PORTA INSERTI A DOPPIO TAGLIENTE PER MACCHINE STOZZATRICI

| ARTICOLO ITEM | A (mm) | B (mm) | L (mm) | Ød (mm) | H (mm) | L1 (mm) | INSERTO INSERT |
|------------------|-----------|-----------|-----------|------------|-----------|------------|-------------------|
| UTDC-0404 | 14 | 19 | 200 | 4 | 10,5 | 42 | INDC-0404 |
| UTDC-0505 | 14 | 19 | 200 | 5 | 11,5 | 52 | INDC-0505 |
| UTDC-0606 | 14 | 19 | 220 | 6 | 17 | 62 | INDC-0606 |
| UTDC-0808 | 14 | 19 | 220 | 8 | - | - | INDC-0808 |
| UTDC-1010 | 18 | 28 | 250 | 10 | - | - | INDC-1010 |
| UTDC-1212 | 22 | 34 | 250 | 12 | - | - | INDC-1212 |
| UTDC-1414 | 22 | 34 | 300 | 14 | - | - | INDC-1414 |
| UTDC-1616 | 24 | 39 | 350 | 16 | - | - | INDC-1616 |
| UTDC-1818 | 29 | 45 | 375 | 18 | - | - | INDC-1818 |
| UTDC-2020 | 35 | 54 | 430 | 20 | - | - | INDC-2020 |

GB DOUBLE CUTTING EDGE HOLDER FOR SLOTTING MACHINES

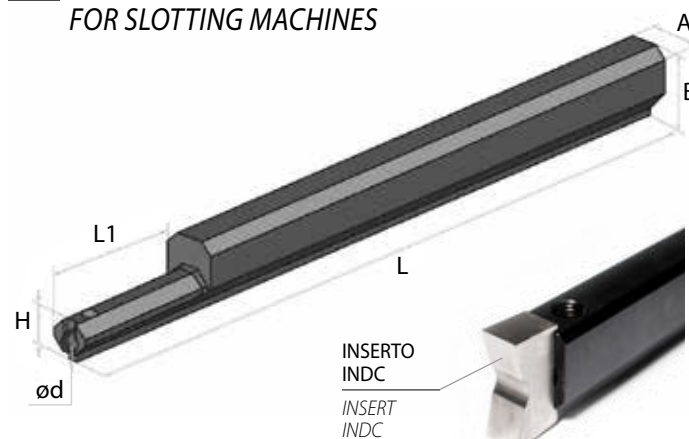



Stozzatore motorizzato

Motorized slotting head

I Lo Stozzatore motorizzato è il nuovo efficiente sistema di stozzatura su torni CNC. L'esperienza maturata dall'azienda BRIGHETTI MECCANICA nel corso degli anni ha permesso di individuare le maggiori problematiche che si presentano nelle lavorazioni di stozzatura e di svilupparne le soluzioni di correzione applicate allo strumento. Questo strumento è stato progettato per ottenere il massimo della rigidità possibile, consentendo quindi un ottimo grado di finitura della superficie lavorata. Inoltre, oltre ad eseguire la lavorazione rapidamente, presenta il grosso vantaggio di poter realizzare questo tipo di lavorazione senza dover ripiazzare il pezzo su un'altra macchina.

GB *The motorized slotting head is the new slotting system for CNC lathes with motorized tool holders. The experience gained during these years in slotting machining gave BRIGHETTI MECCANICA the capacity to understand the biggest set of problems operators meet during a slotting machining and to develop correct solutions to apply to the equipment. This tool was designed to obtain the maximum possible rigidity, thus allowing an optimum finish level of the machined surface. Furthermore, besides the operation being swiftly carried out, it affords a considerable advantage in that this type of processing gets implemented without the setting of the piece having to be repeated or done on another machine.*



OPERATIVITÀ COMPLETA

Con lo stesso stozzatore si possono realizzare brocciature interne ed esterne semplicemente modificando il moto rotativo dell'asse motorizzato del tornio e girando l'utensile di 180°.

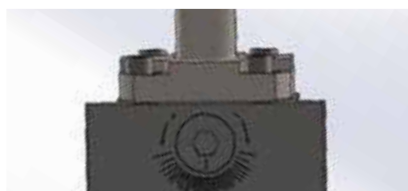

A WHOLE OPERATIVENESS

The same slotting head can be used for both internal and external machinings. It's necessary to change the rotation of the motorized axis and turn the head of 180°.

VERSIONI

Il brocciatore motorizzato **ST** viene **prodotto in 4 diverse tipologie** in relazione alla profondità di lavorazione di brocciatura:

- profondità di 25mm: articolo **ST-25**
- profondità di 35mm: articolo **ST-35**
- profondità di 50mm: articolo **ST-50**
- profondità di 65mm: articolo **ST-65**

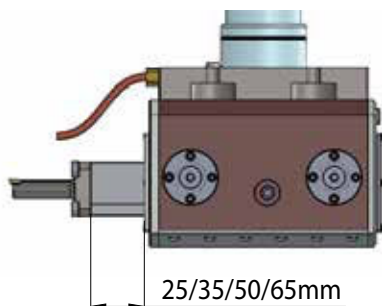

VERSIONS

The **ST** motorized slotting head is **produced with 4 different slotting depth**:

- depth 35 mm: item **ST-25**
- depth 35 mm: item **ST-35**
- depth 50 mm: item **ST-50**
- depth 65 mm: item **ST-65**

UTENSILERIA

Il nostro brocciatore motorizzato monta tutta la serie di utensili appositamente studiati per la realizzazione di sedi di chiavette e profili poligonali. Per ogni tipo di brocciatore motorizzato (ST-25/35/50/65) abbiamo realizzato una specifica serie di utensili che cambiano con il variare della profondità della brocciatura.

TOOLS

The slotting head will be equipped with special insert holders in all types which have been produced for the machining of keyways and polygonal profiles. The programs for slotting head are available for our customers for free. Each type of motorized slotting head will be used with insert holder with specific machining length: 25, 35, 50 and 65 mm.

SCANSIONA I QR CODE CON I TUOI DISPOSITIVI E SCOPRI LE PRINCIPALI FUNZIONALITA' DELLO STOZZATORE MOTORIZZATO

SCAN ALL QR CODES BY YOUR DEVICES AND FIND THE MAIN FEATURES OF THE MOTORIZED SLOTTER HEAD





| SERIE ST | ARTICOLO-ITEM (materiale - material) | L1 (mm) | L3 (mm) | L4 (mm) | L5 (mm) | L6 (mm) | D1 (mm) | foro minimo - minimum hole (mm) |
|-------------|---|------------|------------|------------|------------|------------|------------|---------------------------------------|
| | HARDENED | | | | | | | |
| 25 | UTM-02-25 | 26 | 8 | 9 | 27,5 | 19 | 6,5 | 7 |
| | UTM-03-25 | 26 | 8 | 9 | 27,5 | 19 | 8 | 8,7 |
| | UTM-04-25 | 26 | 8 | 9 | 27,5 | 19 | 10 | 11 |
| | UTM-05-25 | 26 | 8 | 9 | 27,5 | 19 | 12 | 13 |
| | UTM-06-25 | 26 | 8 | 9 | 27,5 | 19 | 15 | 17 |
| 35 | UTM-02-35 | 25 | 13 | 20 | 43 | 35 | 6 | 7 |
| | UTM-03-35 | 30 | 13 | 20 | 43 | 35 | 8 | 8,7 |
| | UTM-04-35 | 40 | 13 | 20 | 43 | 35 | 10 | 11 |
| | UTM-05-35 | 46 | 13 | 20 | 43 | 35 | 12 | 13 |
| | UTM-06-35 | 46 | 13 | 20 | 43 | 35 | 16 | 17 |
| | UTM-08-35 | 46 | 13 | 20 | 43 | 35 | 20 | 21,5 |
| | UTM-10-35 | 46 | 13 | 20 | 43 | 35 | 22 | 24 |
| UTM-14-35 | 46 | 13 | 20 | 43 | 35 | 25 | 27 | |
| 50 | UTM-02-50 | 25 | 13 | 20 | 43 | 35 | 6 | 7 |
| | UTM-03-50 | 30 | 13 | 20 | 43 | 35 | 8 | 8,7 |
| | UTM-04-50 | 40 | 13 | 20 | 43 | 35 | 10 | 11 |
| | UTM-05-50 | 46 | 13 | 20 | 43 | 35 | 12 | 13 |
| | UTM-06-50 | 56 | 13 | 20 | 43 | 35 | 16 | 17 |
| | UTM-08-50 | 56 | 13 | 20 | 43 | 35 | 20 | 21,5 |
| | UTM-10-50 | 56 | 13 | 20 | 43 | 35 | 22 | 24 |
| | UTM-14-50 | 56 | 13 | 20 | 43 | 35 | 25 | 27 |
| 65 | UTM-02-65 | 25 | 13 | 20 | 43 | 35 | 6 | 7 |
| | UTM-03-65 | 30 | 13 | 20 | 43 | 35 | 8 | 8,7 |
| | UTM-04-65 | 40 | 13 | 20 | 43 | 35 | 10 | 11 |
| | UTM-05-65 | 46 | 13 | 20 | 43 | 35 | 12 | 13 |
| | UTM-06-65 | 56 | 13 | 20 | 43 | 35 | 16 | 17 |
| | UTM-08-65 | 68 | 13 | 20 | 43 | 35 | 20 | 21,5 |
| | UTM-10-65 | 70 | 13 | 20 | 43 | 35 | 22 | 24 |
| | UTM-14-65 | 70 | 13 | 20 | 43 | 35 | 25 | 27 |

Porta inserto **UTM** per esecuzione di **chiavette**
UTM series insert holder for machining keyways

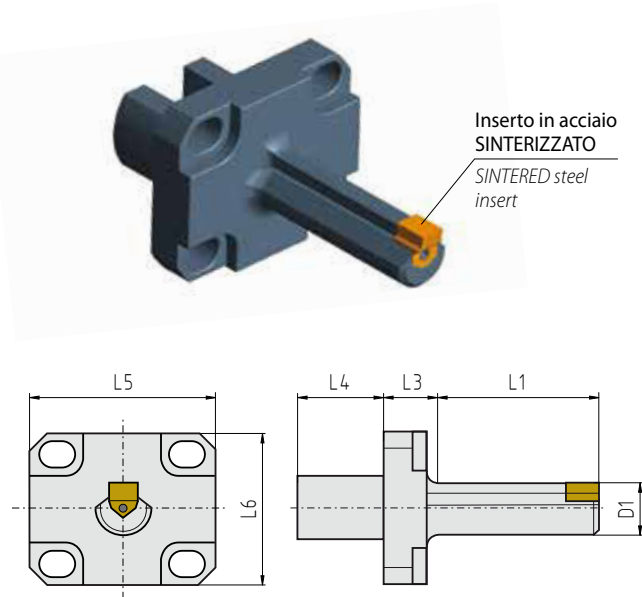

| SERIE ST | ARTICOLO-ITEM (materiale - material) | L1 (mm) | L3 (mm) | L4 (mm) | L5 (mm) | L6 (mm) | D1 (mm) | foro minimo - minimum hole (mm) |
|-------------|---|------------|------------|------------|------------|------------|------------|---------------------------------------|
| | HARDENED | | | | | | | |
| 25 | UTM-HEX-09/11-25 | 26 | 8 | 9 | 27,5 | 19 | 8 | 8,7 |
| | UTM-HEX-11/17-25 | 26 | 8 | 9 | 27,5 | 19 | 10 | 11,55 |
| | UTM-HEX-17/28-25 | 26 | 8 | 9 | 27,5 | 19 | 15 | 16 |
| 35 | UTM-HEX-09/11-35 | 30 | 13 | 20 | 43 | 35 | 8 | 8,7 |
| | UTM-HEX-11/17-35 | 40 | 13 | 20 | 43 | 35 | 10 | 10 |
| | UTM-HEX-17/28-35 | 46 | 13 | 20 | 43 | 35 | 15 | 16 |
| | UTM-HEX-28/37-35 | 46 | 13 | 20 | 43 | 35 | 25 | 27 |
| | UTM-HEX-37/45-35 | 46 | 13 | 20 | 43 | 35 | 28 | 30 |
| 50 | UTM-HEX-09/11-50 | 30 | 13 | 20 | 43 | 35 | 8 | 8,7 |
| | UTM-HEX-11/17-50 | 40 | 13 | 20 | 43 | 35 | 10 | 10 |
| | UTM-HEX-17/28-50 | 60 | 13 | 20 | 43 | 35 | 15 | 16 |
| | UTM-HEX-28/37-50 | 60 | 13 | 20 | 43 | 35 | 25 | 27 |
| | UTM-HEX-37/45-50 | 60 | 13 | 20 | 43 | 35 | 28 | 30 |
| 65 | UTM-HEX-09/11-65 | 30 | 13 | 20 | 43 | 35 | 8 | 8,7 |
| | UTM-HEX-11/17-65 | 40 | 13 | 20 | 43 | 35 | 10 | 10 |
| | UTM-HEX-17/28-65 | 60 | 13 | 20 | 43 | 35 | 15 | 16 |
| | UTM-HEX-28/37-65 | 75 | 13 | 20 | 43 | 35 | 25 | 27 |
| | UTM-HEX-37/45-65 | 75 | 13 | 20 | 43 | 35 | 28 | 30 |

Porta inserto **UTM-HEX** per esecuzione di **profili esagonali**
UTM-HEX series insert holder for machining hexagonal profiles

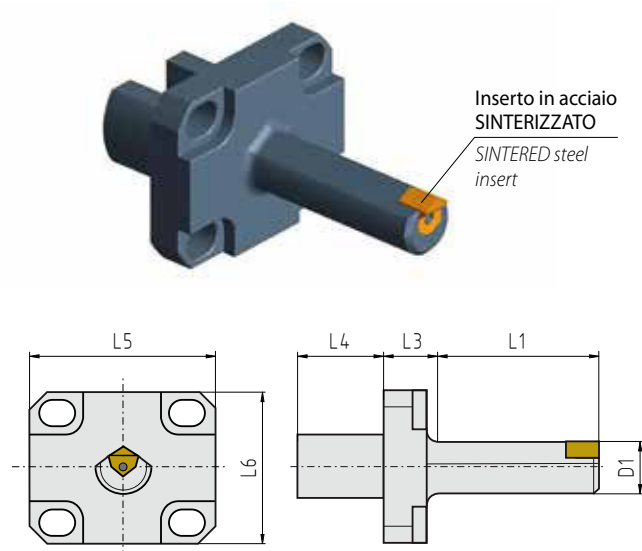



| SERIE ST | ARTICOLO-ITEM (materiale - material) | L1 (mm) | L3 (mm) | L4 (mm) | L5 (mm) | L6 (mm) | D1 (mm) | foro minimo - minimum hole (mm) |
|-------------|---|------------|------------|------------|------------|------------|------------|---------------------------------------|
| | HARDENED | | | | | | | |
| 25 | UTM-SQ-08/10-25 | 26 | 8 | 8 | 27,5 | 19 | 8 | 8,5 |
| | UTM-SQ-10/13-25 | 26 | 8 | 8 | 27,5 | 19 | 8,6 | 10 |
| | UTM-SQ-13/16-25 | 26 | 8 | 8 | 27,5 | 19 | 12 | 13 |
| 35 | UTM-SQ-08/10-35 | 30 | 13 | 20 | 43 | 35 | 7,25 | 8 |
| | UTM-SQ-10/13-35 | 40 | 13 | 20 | 43 | 35 | 8,6 | 10 |
| | UTM-SQ-13/16-35 | 46 | 13 | 20 | 43 | 35 | 12 | 13 |
| | UTM-SQ-16/19-35 | 46 | 13 | 20 | 43 | 35 | 15 | 16 |
| | UTM-SQ-19/27-35 | 46 | 13 | 20 | 43 | 35 | 18,5 | 19 |
| | UTM-SQ-27/37-35 | 46 | 13 | 20 | 43 | 35 | 25 | 27 |
| 50 | UTM-SQ-08/10-50 | 30 | 13 | 20 | 43 | 35 | 7,25 | 8 |
| | UTM-SQ-10/13-50 | 40 | 13 | 20 | 43 | 35 | 8,6 | 10 |
| | UTM-SQ-13/16-50 | 50 | 13 | 20 | 43 | 35 | 12 | 13 |
| | UTM-SQ-16/19-50 | 52 | 13 | 20 | 43 | 35 | 15 | 16 |
| | UTM-SQ-19/27-50 | 60 | 13 | 20 | 43 | 35 | 18,5 | 19 |
| | UTM-SQ-27/37-50 | 60 | 13 | 20 | 43 | 35 | 25 | 27 |
| 65 | UTM-SQ-08/10-65 | 30 | 13 | 20 | 43 | 35 | 7,25 | 8 |
| | UTM-SQ-10/13-65 | 40 | 13 | 20 | 43 | 35 | 8,6 | 10 |
| | UTM-SQ-13/16-65 | 50 | 13 | 20 | 43 | 35 | 12 | 13 |
| | UTM-SQ-16/19-65 | 52 | 13 | 20 | 43 | 35 | 15 | 16 |
| | UTM-SQ-19/27-65 | 75 | 13 | 20 | 43 | 35 | 18,5 | 19 |
| | UTM-SQ-27/37-65 | 75 | 13 | 20 | 43 | 35 | 25 | 27 |

Porta inserto **UTM-SQ** per esecuzione di **profili quadri**
UTM-SQ series insert holder for machining square profiles

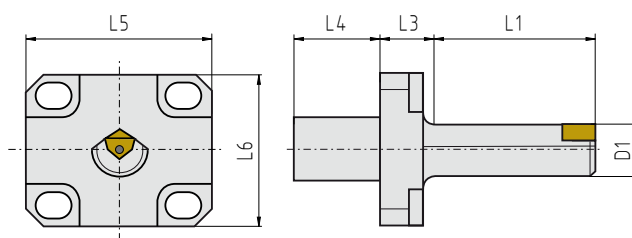
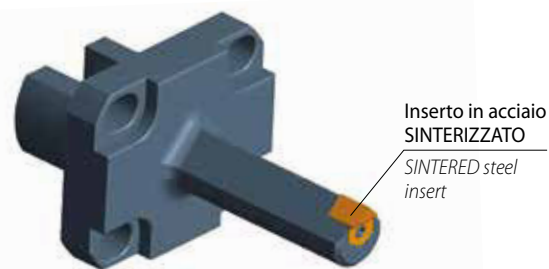

PROGRAMMAZIONE MACCHINA

Grazie all'esperienza maturata negli anni con l'impiego dei nostri utensili BT/BTA, abbiamo sviluppato anche per il brocciatore motorizzato i programmi macchina per i più diffusi controlli CNC. Anche in questo caso i programmi sono a disposizione dei nostri clienti gratuitamente.

PARAMETRI DI TAGLIO

Per garantire una lunga durata dell'inserto e un'ottima finitura nella lavorazione, è consigliabile attenersi ai parametri suggeriti (vedi tabella parametri).

Spessore massimo realizzabile sui vari materiali e parametri di taglio:

MACHINE TOOL PROGRAMMING

As the experience with programs for standard slotting machining has been a good one, to help using this new instrument, our technicians developed new programs to quickly and easily set up the motorized slotting head. These new programs are suitable for the most popular CNC software now on the market.

CUTTING PARAMETERS

To guarantee a lengthy duration of the insert and an optimal machining finish, it is advisable to keep to the suggested parameters (refer to the parameters table).

Maximum thickness obtainable on various materials and cutting parameters:

| materiale / material | Corsa/Stroke 25 mm | Corsa/Stroke 35 mm | Corsa/Stroke 50 mm | Corsa/Stroke 65 mm | Velocità di taglio/ Cutting speed | Incremento/ Increment |
|-------------------------------------|-----------------------|-----------------------|-----------------------|-----------------------|--------------------------------------|--------------------------|
| Alluminio / Aluminium | 8 mm | 16 mm | 16 mm | 16 mm | 38 m/min. | 0,06 / 0,15 mm |
| Acciaio tenero / Mild steel | 6 mm | 14 mm | 14 mm | 14 mm | 33 m/min. | 0,03 / 0,05 mm |
| Ghisa / Cast iron | 6 mm | 14 mm | 14 mm | 12 mm | 28 m/min. | 0,03 / 0,05 mm |
| Acciaio comune / Common steel | 6 mm | 14 mm | 14 mm | 12 mm | 30 m/min. | 0,03 / 0,05 mm |
| Acciaio bonificato / Hardened steel | 6 mm | 12 mm | 12 mm | 10 mm | 25 m/min. | 0,02 / 0,04 mm |
| Acciaio inox / Stainless steel | 6 mm | 12 mm | 12 mm | 10 mm | 25 m/min. | 0,02 / 0,03 mm |
| Plastica / Plastic | 8 mm | 18 mm | 18 mm | 18 mm | 40 m/min. | 0,07 / 0,15 mm |
| Bronzo - Ottone / Bronze - Brass | 6 mm | 14 mm | 12 mm | 12 mm | 30 m/min. | 0,03 / 0,06 mm |



Valigette kit Tool box kits

I Per andare incontro alle richieste di alcuni nostri clienti, abbiamo realizzato n.4 valigette con all'interno i KIT DI PORTAINSERTI E INSERTE per l'utilizzo su CNC, centri di lavoro e macchine stozzatrici. Le valigette sono disponibili con inserti in acciaio sinterizzato (IN) o metallo duro (INHMM).

GB To meet the demands of some of our customers, we have created 4 tool box kits with the INSERT HOLDER KITS AND INSERTS for use on CNCs, machining centers and slotting machines. The tool box kits are available with sintered steel (IN) or hard metal (INHMM) inserts.



Lavorazione su torni / Operation on: CNC E CENTRI DI LAVORO / CNC LATHES AND MACHINING CENTERS



| | |
|--------------------------------------|-------------------------------------|
| Codice / Code | UTKITS |
| Materiale inserti / Inserts material | Sinterizzato / Sintered (IN) |

Contenuto, montaggio e utilizzo / Content, assembly and use
 su/on UT-03: IN-03
 su/on UT-04: IN-04 oppure/or IN-05
 su/on UT-06: IN-06 oppure/or IN-08
 su/on UT-10: IN-10 oppure/or IN-12

Tolleranze inserti "IN" / Tolerance "IN" inserts
 P9 / H7 / D10 / C11

Rivestimenti PVD / PVD coatings
 TIN

Quantità / Quantity
 n.2 pezzi per ogni misura di inserto / no. 2 pieces for each insert size

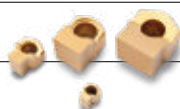

| | |
|--------------------------------------|--|
| Codice / Code | UTKITHM |
| Materiale inserti / Inserts material | Metallo duro / Hard metal (INHMM) |

Contenuto, montaggio e utilizzo / Content, assembly and use
 su/on UT-03: INHM-03
 su/on UT-04: INHM-04 oppure/or INHM-05
 su/on UT-06: INHM-06 oppure/or INHM-08
 su/on UT-10: INHM-10 oppure/or INHM-12

Tolleranze inserti "INHMM" / Tolerance "INHMM" inserts
 H7 / D10 / C11

Rivestimenti PVD / PVD coatings
 HDP RED

Quantità / Quantity
 n.2 pezzi per ogni misura di inserto / no. 2 pieces for each insert size



Lavorazione su torni / Operation on: STOZZATRICI / SLOTTING MACHINES



| | |
|--------------------------------------|-------------------------------------|
| Codice / Code | UTSZKITS |
| Materiale inserti / Inserts material | Sinterizzato / Sintered (IN) |

Contenuto, montaggio e utilizzo / Content, assembly and use
 su/on UT SZ-03120: IN-03
 su/on UT SZ-04120: IN-04 oppure/or IN-05
 su/on UT SZ-06: IN-06 oppure/or IN-08
 su/on UT SZ-10: IN-10 oppure/or IN-12

Tolleranze inserti "IN" / Tolerance "IN" inserts
 P9 / H7 / D10 / C11

Rivestimenti PVD / PVD coatings
 TIN

Quantità / Quantity
 n.2 pezzi per ogni misura di inserto / no. 2 pieces for each insert size



| | |
|--------------------------------------|--|
| Codice / Code | UTSZKITHM |
| Materiale inserti / Inserts material | Metallo duro / Hard metal (INHMM) |

Contenuto, montaggio e utilizzo / Content, assembly and use
 su/on UT SZ-03120: INHM-03
 su/on UT SZ-04120: INHM-04 oppure/or INHM-05
 su/on UT SZ-06: INHM-06 oppure/or INHM-08
 su/on UT SZ-10: INHM-10 oppure/or INHM-12

Tolleranze inserti "INHMM" / Tolerance "INHMM" inserts
 H7 / D10 / C11

Rivestimenti PVD / PVD coatings
 HDP RED

Quantità / Quantity
 n.2 pezzi per ogni misura di inserto / no. 2 pieces for each insert size

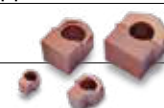



Bussole di riduzione

Reduction bushes



I Le bussole di riduzione con battuta consentono il fissaggio di barenì o punte con codolo cilindrico o a cono morse su portautensili di macchine a controllo numerico.

La nostra produzione di bussole si articola su diversi tipi:

- > bussole cilindriche con fissaggio dell'utensile a mezzo di grani
- > bussole cilindriche asolate con fissaggio diretto dell'utensile
- > bussole coniche
- > bussole con passaggio del refrigerante
- > bussole elastiche
- > bussole elastiche per barre antivibranti

Per ogni tipo sono previste diverse misure formando così una gamma completa che può soddisfare le più svariate esigenze.

GB *The reduction bushes with flanges allow boring bars or drills with a cylindrical shaft or clamp cone to be fixed to the tool holders of numerically controlled machine tools.*

Five different types of bushes are available:

- > *Cylindrical bushes to be fixed to tool by means of screws*
- > *Cylindrical slotted bushes to be directly fastened to tool*
- > *Conical bushes*
- > *Bushes with flow of cooling liquid*
- > *Elastic bushes*
- > *Elastic bushes for vibration damper bar*

We manufacture each type of bush in different sizes, in order to offer a complete range capable of meeting every need.



BUSSOLE CILINDRICHE CYLINDRICAL BUSHES

D=16 mm

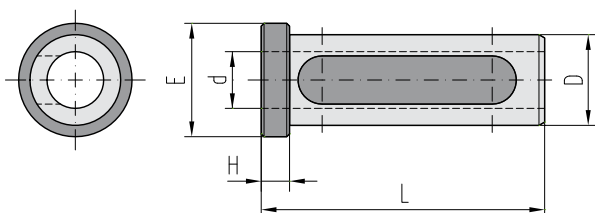

| ARTICOLO-ITEM | D h7 | d H7 | L | H | E |
|-------------------|------|------|----|---|----|
| B-16-6-50 | 16 | 6 | 50 | 5 | 20 |
| B-16-8-50 | 16 | 8 | 50 | 5 | 20 |
| B-16-10-50 | 16 | 10 | 50 | 5 | 20 |
| B-16-12-50 | 16 | 12 | 50 | 5 | 20 |

D=19,05 mm (3/4")

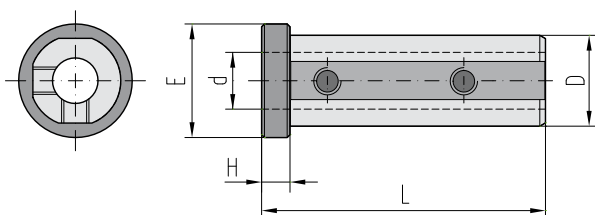

| ARTICOLO-ITEM | D h7 | d H7 | L | H | E |
|---------------------|-------|------|----|---|----|
| B19,05-6-60 | 19,05 | 6 | 60 | 6 | 27 |
| B19,05-8-60 | 19,05 | 8 | 60 | 6 | 27 |
| B19,05-10-60 | 19,05 | 10 | 60 | 6 | 27 |

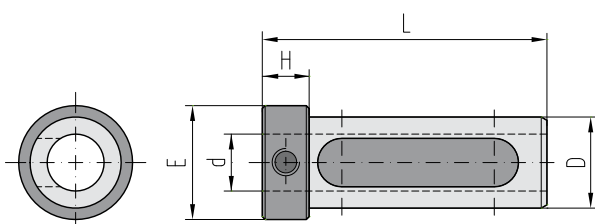

| ARTICOLO-ITEM | D h7 | d H7 | L | H | E |
|---------------------|-------|------|----|----|----|
| B19,05-12-60 | 19,05 | 12 | 60 | 10 | 27 |
| B19,05-14-60 | 19,05 | 14 | 60 | 10 | 27 |
| B19,05-16-60 | 19,05 | 16 | 60 | 10 | 27 |

D=20 mm

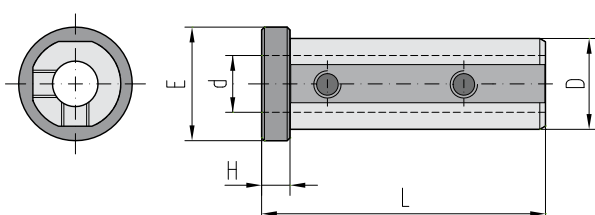

| ARTICOLO-ITEM | D h7 | d H7 | L | H | E |
|------------------|------|------|----|---|----|
| B20-6-60 | 20 | 6 | 60 | 6 | 27 |
| B20-8-60 | 20 | 8 | 60 | 6 | 27 |
| B20-10-60 | 20 | 10 | 60 | 6 | 27 |

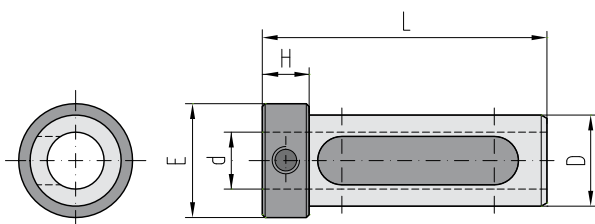

| ARTICOLO-ITEM | D h7 | d H7 | L | H | E |
|------------------|------|------|----|----|----|
| B20-12-60 | 20 | 12 | 60 | 10 | 27 |
| B20-14-60 | 20 | 14 | 60 | 10 | 27 |
| B20-16-60 | 20 | 16 | 60 | 10 | 27 |



D=22 mm

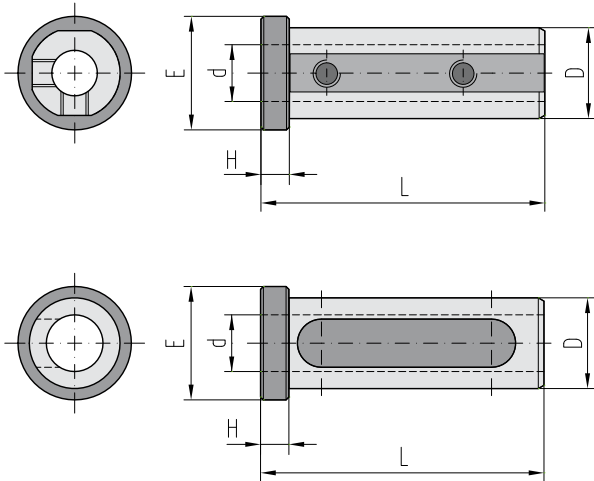

| ARTICOLO-ITEM | D h7 | d H7 | L | H | E |
|------------------|------|------|----|---|----|
| B22-6-60 | 22 | 6 | 60 | 6 | 28 |
| B22-8-60 | 22 | 8 | 60 | 6 | 28 |
| B22-10-60 | 22 | 10 | 60 | 6 | 28 |

| ARTICOLO-ITEM | D h7 | d H7 | L | H | E |
|------------------|------|------|----|---|----|
| B22-12-60 | 22 | 12 | 60 | 6 | 28 |
| B22-14-60 | 22 | 14 | 60 | 6 | 28 |
| B22-16-60 | 22 | 16 | 60 | 6 | 28 |

D=25 mm

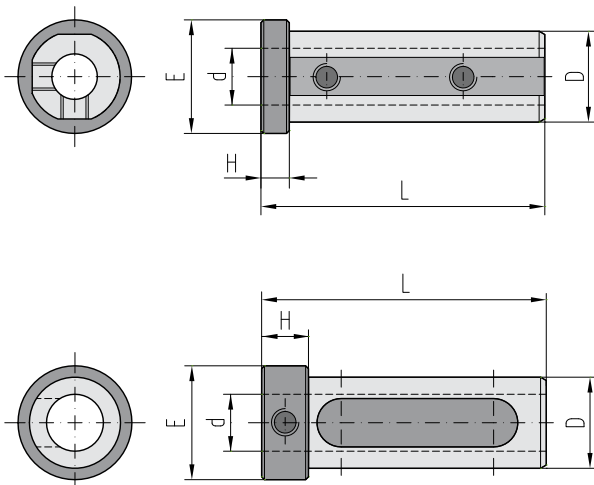

| ARTICOLO-ITEM | D h7 | d H7 | L | H | E |
|------------------|------|------|----|---|----|
| B25-6-60 | 25 | 6 | 60 | 6 | 33 |
| B25-8-60 | 25 | 8 | 60 | 6 | 33 |
| B25-10-60 | 25 | 10 | 60 | 6 | 33 |
| B25-12-60 | 25 | 12 | 60 | 6 | 33 |

| ARTICOLO-ITEM | D h7 | d H7 | L | H | E |
|------------------|------|------|----|----|----|
| B25-14-70 | 25 | 14 | 70 | 13 | 33 |
| B25-16-70 | 25 | 16 | 70 | 13 | 33 |
| B25-18-70 | 25 | 18 | 70 | 13 | 33 |
| B25-20-70 | 25 | 20 | 70 | 13 | 33 |

D=25,40 mm (1")

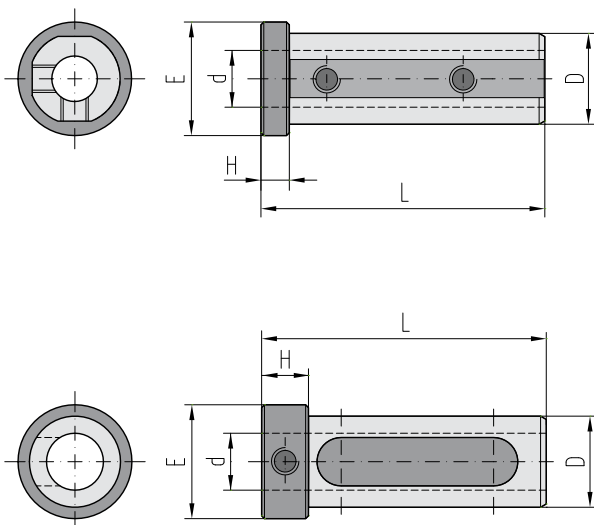

| ARTICOLO-ITEM | D h7 | d H7 | L | H | E |
|---------------------|-------|------|----|---|----|
| B25,40-6-60 | 25,40 | 6 | 60 | 6 | 33 |
| B25,40-8-60 | 25,40 | 8 | 60 | 6 | 33 |
| B25,40-10-60 | 25,40 | 10 | 60 | 6 | 33 |
| B25,40-12-60 | 25,40 | 12 | 60 | 6 | 33 |

| ARTICOLO-ITEM | D h7 | d H7 | L | H | E |
|---------------------|-------|------|----|----|----|
| B25,40-14-70 | 25,40 | 14 | 70 | 13 | 33 |
| B25,40-16-70 | 25,40 | 16 | 70 | 13 | 33 |
| B25,40-18-70 | 25,40 | 18 | 70 | 13 | 33 |
| B25,40-20-70 | 25,40 | 20 | 70 | 13 | 33 |



D=32 mm

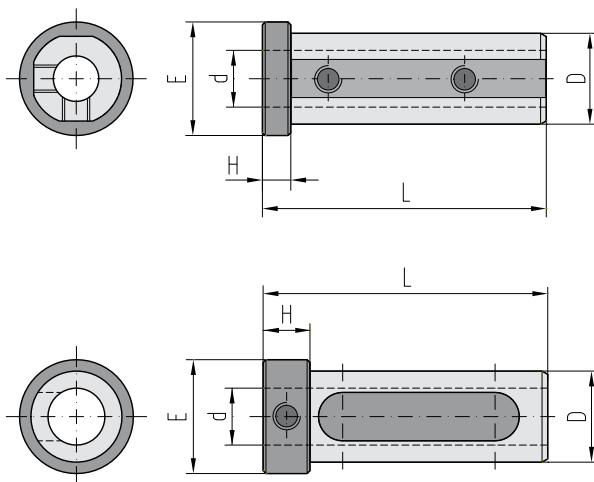

| ARTICOLO-ITEM | D h7 | d H7 | L | H | E |
|------------------|------|------|----|---|----|
| B32-6-60 | 32 | 6 | 60 | 6 | 39 |
| B32-8-70 | 32 | 8 | 70 | 8 | 39 |
| B32-10-70 | 32 | 10 | 70 | 8 | 39 |
| B32-12-70 | 32 | 12 | 70 | 8 | 39 |
| B32-14-70 | 32 | 14 | 70 | 8 | 39 |
| B32-16-70 | 32 | 16 | 70 | 8 | 39 |
| B32-18-70 | 32 | 18 | 70 | 8 | 39 |
| B32-20-70 | 32 | 20 | 70 | 8 | 39 |

| ARTICOLO-ITEM | D h7 | d H7 | L | H | E |
|------------------|------|------|----|----|----|
| B32-25-80 | 32 | 25 | 80 | 15 | 39 |

D=35 mm

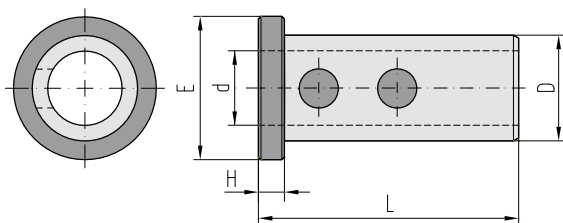

| ARTICOLO-ITEM | D h7 | d H7 | L | H | E |
|------------------|------|------|----|---|----|
| B35-8-80 | 35 | 8 | 80 | 8 | 44 |
| B35-10-80 | 35 | 10 | 80 | 8 | 44 |
| B35-12-80 | 35 | 12 | 80 | 8 | 44 |
| B35-16-80 | 35 | 16 | 80 | 8 | 44 |
| B35-20-80 | 35 | 20 | 80 | 8 | 44 |
| B35-25-80 | 35 | 25 | 80 | 8 | 44 |
| B35-32-80 | 35 | 32 | 80 | 8 | 44 |

D=40 mm

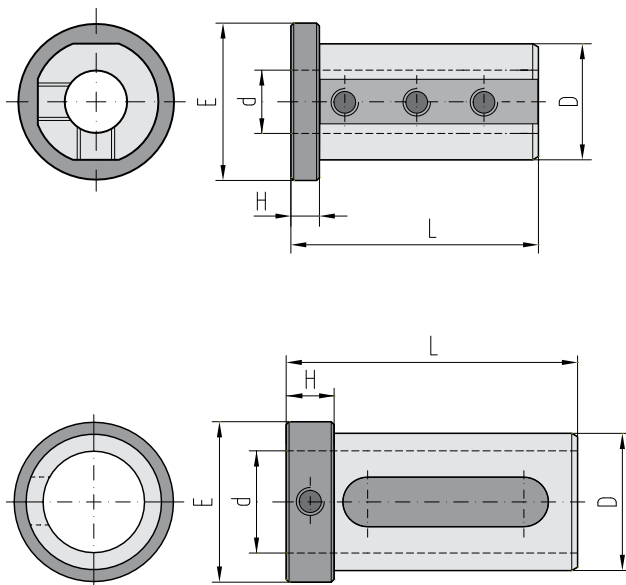

| ARTICOLO-ITEM | D h7 | d H7 | L | H | E |
|------------------|------|------|----|---|----|
| B40-6-60 | 40 | 6 | 60 | 6 | 49 |
| B40-8-80 | 40 | 8 | 80 | 8 | 49 |
| B40-10-80 | 40 | 10 | 80 | 8 | 49 |
| B40-12-80 | 40 | 12 | 80 | 8 | 49 |
| B40-14-80 | 40 | 14 | 80 | 8 | 49 |
| B40-16-80 | 40 | 16 | 80 | 8 | 49 |
| B40-18-80 | 40 | 18 | 80 | 8 | 49 |
| B40-20-80 | 40 | 20 | 80 | 8 | 49 |
| B40-25-80 | 40 | 25 | 80 | 8 | 49 |

| ARTICOLO-ITEM | D h7 | d H7 | L | H | E |
|------------------|------|------|----|----|----|
| B40-20-90 | 40 | 20 | 90 | 15 | 49 |
| B40-25-90 | 40 | 25 | 90 | 15 | 49 |
| B40-32-90 | 40 | 32 | 90 | 15 | 49 |



D=45 mm

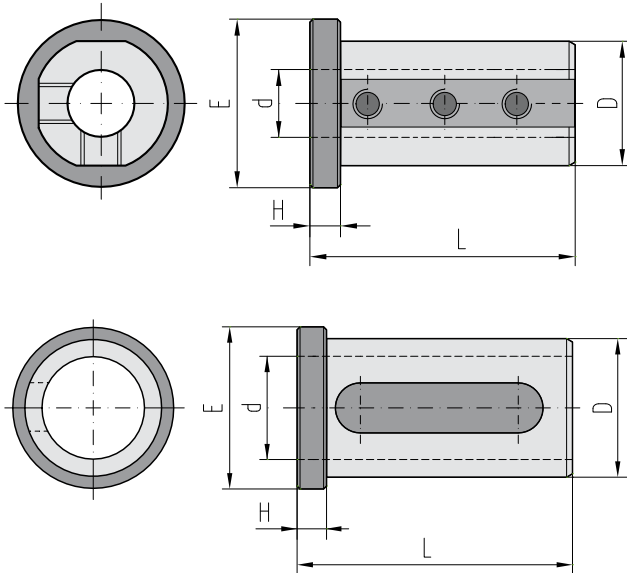

| ARTICOLO-ITEM | D h7 | d H7 | L | H | E |
|------------------|------|------|----|---|----|
| B45-8-80 | 45 | 8 | 80 | 8 | 54 |
| B45-10-80 | 45 | 10 | 80 | 8 | 54 |
| B45-12-80 | 45 | 12 | 80 | 8 | 54 |
| B45-16-80 | 45 | 16 | 80 | 8 | 54 |
| B45-20-80 | 45 | 20 | 80 | 8 | 54 |
| B45-25-80 | 45 | 25 | 80 | 8 | 54 |

| ARTICOLO-ITEM | D h7 | d H7 | L | H | E |
|------------------|------|------|----|---|----|
| B45-32-80 | 45 | 32 | 80 | 8 | 54 |
| B45-40-80 | 45 | 40 | 80 | 8 | 54 |

D=50 mm

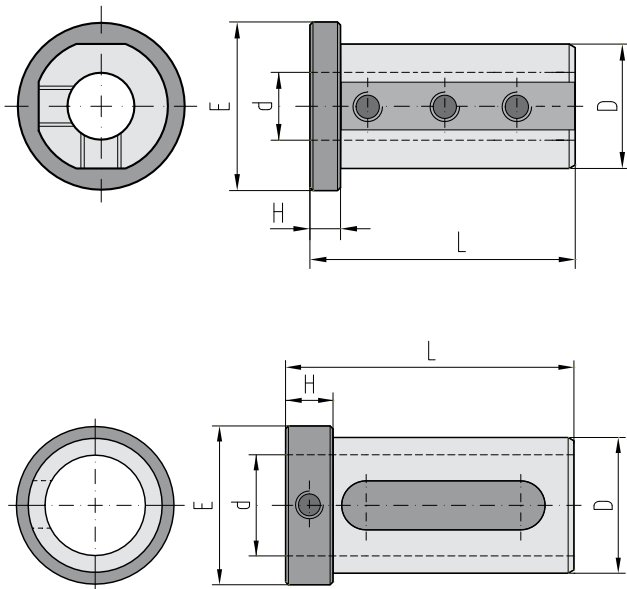

| ARTICOLO-ITEM | D h7 | d H7 | L | H | E |
|------------------|------|------|----|---|----|
| B50-8-90 | 50 | 8 | 90 | 8 | 59 |
| B50-10-90 | 50 | 10 | 90 | 8 | 59 |
| B50-12-90 | 50 | 12 | 90 | 8 | 59 |
| B50-14-90 | 50 | 14 | 90 | 8 | 59 |
| B50-16-90 | 50 | 16 | 90 | 8 | 59 |
| B50-18-90 | 50 | 18 | 90 | 8 | 59 |
| B50-20-90 | 50 | 20 | 90 | 8 | 59 |
| B50-25-90 | 50 | 25 | 90 | 8 | 59 |
| B50-32-90 | 50 | 32 | 90 | 8 | 59 |

| ARTICOLO-ITEM | D h7 | d H7 | L | H | E |
|-------------------|------|------|-----|----|----|
| B50-40-100 | 50 | 40 | 100 | 15 | 59 |

D=60 mm

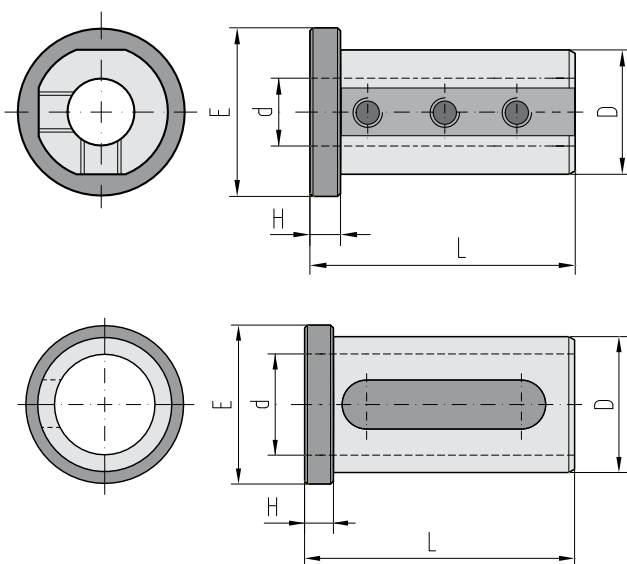

| ARTICOLO-ITEM | D h7 | d H7 | L | H | E |
|------------------|------|------|----|---|----|
| B60-12-97 | 60 | 12 | 97 | 8 | 69 |
| B60-16-97 | 60 | 16 | 97 | 8 | 69 |
| B60-20-97 | 60 | 20 | 97 | 8 | 69 |
| B60-25-97 | 60 | 25 | 97 | 8 | 69 |
| B60-32-97 | 60 | 32 | 97 | 8 | 69 |

| ARTICOLO-ITEM | D h7 | d H7 | L | H | E |
|------------------|------|------|----|----|----|
| B60-40-97 | 60 | 40 | 97 | 15 | 69 |
| B60-50-97 | 60 | 50 | 97 | 15 | 69 |



BUSSOLE CONICHE CONICAL BUSHES

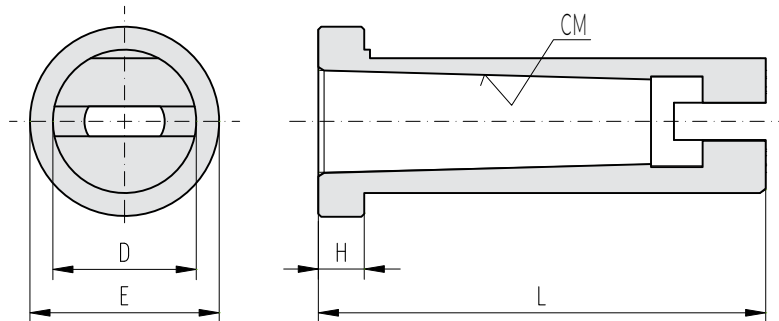

D=25 mm

| ARTICOLO-ITEM | D h7 | CM | L | H | E |
|------------------|------|----|----|---|----|
| BC25-1-65 | 25 | 1 | 65 | 6 | 33 |
| BC25-2-78 | 25 | 2 | 78 | 8 | 33 |

D=25,40 mm (1")

| ARTICOLO-ITEM | D h7 | CM | L | H | E |
|---------------------|-------|----|----|---|----|
| BC25,40-1-65 | 25,40 | 1 | 65 | 6 | 33 |
| BC25,40-2-78 | 25,40 | 2 | 78 | 8 | 33 |

D=32 mm

| ARTICOLO-ITEM | D h7 | CM | L | H | E |
|------------------|------|----|----|---|----|
| BC32-1-65 | 32 | 1 | 65 | 6 | 39 |
| BC32-2-78 | 32 | 2 | 78 | 8 | 39 |
| BC32-3-97 | 32 | 3 | 97 | 8 | 39 |

D=40 mm

| ARTICOLO-ITEM | D h7 | CM | L | H | E |
|-------------------|------|----|-----|---|----|
| BC40-1-65 | 40 | 1 | 65 | 6 | 49 |
| BC40-2-78 | 40 | 2 | 78 | 8 | 49 |
| BC40-3-97 | 40 | 3 | 97 | 8 | 49 |
| BC40-4-120 | 40 | 4 | 120 | 8 | 49 |

D=45 mm

| ARTICOLO-ITEM | D h7 | CM | L | H | E |
|-------------------|------|----|-----|---|----|
| BC45-2-78 | 45 | 2 | 78 | 8 | 54 |
| BC45-3-97 | 45 | 3 | 97 | 8 | 54 |
| BC45-4-120 | 45 | 4 | 120 | 8 | 54 |

D=50 mm

| ARTICOLO-ITEM | D h7 | CM | L | H | E |
|-------------------|------|----|-----|---|----|
| BC50-2-78 | 50 | 2 | 78 | 8 | 59 |
| BC50-3-97 | 50 | 3 | 97 | 8 | 59 |
| BC50-4-120 | 50 | 4 | 120 | 8 | 59 |

D=60 mm

| ARTICOLO-ITEM | D h7 | CM | L | H | E |
|-------------------|------|----|-----|---|----|
| BC60-2-78 | 60 | 2 | 78 | 8 | 69 |
| BC60-3-97 | 60 | 3 | 97 | 8 | 69 |
| BC60-4-120 | 60 | 4 | 120 | 8 | 69 |
| BC60-5-155 | 60 | 5 | 155 | 8 | 69 |



BUSSOLE CON PASSAGGIO DEL REFRIGERANTE

BUSHES WITH FLOW OF COOLING LIQUID

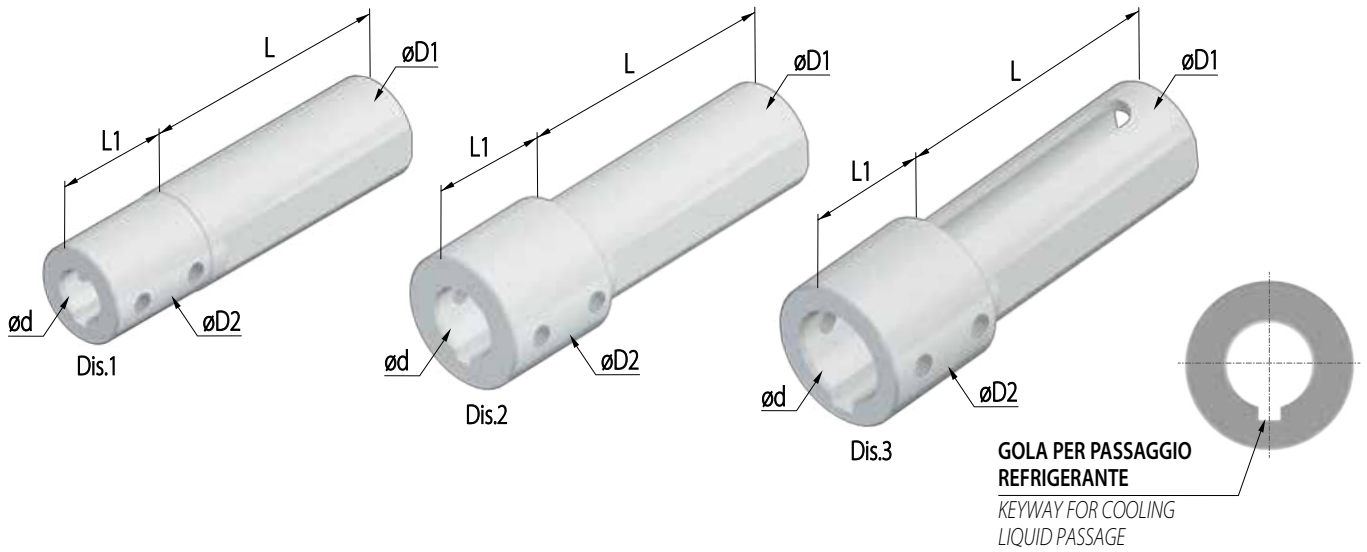

D=25 mm

| ARTICOLO-ITEM | D1 h7 | D2 | d H7 | L | L1 | Rif.-Ref. |
|---------------|-------|------|------|----|----|-----------|
| BL 25-6 | 25 | 24,5 | 6 | 65 | 30 | Dis.1 |
| BL 25-8 | 25 | 24,5 | 8 | 65 | 30 | Dis.1 |
| BL 25-10 | 25 | 24,5 | 10 | 65 | 30 | Dis.1 |
| BL 25-12 | 25 | 24,5 | 12 | 65 | 30 | Dis.1 |

| | | | | | | |
|----------|----|----|----|----|----|-------|
| BL 25-16 | 25 | 32 | 16 | 65 | 30 | Dis.2 |
|----------|----|----|----|----|----|-------|

| | | | | | | |
|----------|----|----|----|----|----|-------|
| BL 25-20 | 25 | 32 | 20 | 65 | 30 | Dis.3 |
|----------|----|----|----|----|----|-------|

D=40 mm

| ARTICOLO-ITEM | D1 h7 | D2 | d H7 | L | L1 | Rif.-Ref. |
|---------------|-------|------|------|----|----|-----------|
| BL 40-6 | 40 | 31,5 | 6 | 65 | 30 | Dis.1 |
| BL 40-8 | 40 | 31,5 | 8 | 65 | 30 | Dis.1 |
| BL 40-10 | 40 | 31,5 | 10 | 65 | 30 | Dis.1 |
| BL 40-12 | 40 | 31,5 | 12 | 65 | 30 | Dis.1 |
| BL 40-14 | 40 | 31,5 | 14 | 65 | 30 | Dis.1 |
| BL 40-16 | 40 | 31,5 | 16 | 65 | 30 | Dis.1 |

| | | | | | | |
|----------|----|------|----|----|----|-------|
| BL 40-18 | 40 | 47,5 | 18 | 65 | 30 | Dis.2 |
|----------|----|------|----|----|----|-------|

| | | | | | | |
|----------|----|------|----|----|----|-------|
| BL 40-20 | 40 | 47,5 | 20 | 65 | 30 | Dis.2 |
|----------|----|------|----|----|----|-------|

| | | | | | | |
|----------|----|------|----|----|----|-------|
| BL 40-25 | 40 | 47,5 | 25 | 65 | 30 | Dis.2 |
|----------|----|------|----|----|----|-------|

| | | | | | | |
|----------|----|------|----|----|----|-------|
| BL 40-32 | 40 | 47,5 | 32 | 65 | 30 | Dis.3 |
|----------|----|------|----|----|----|-------|

D=32 mm

| ARTICOLO-ITEM | D1 h7 | D2 | d H7 | L | L1 | Rif.-Ref. |
|---------------|-------|----|------|----|----|-----------|
| BL 32-6 | 32 | 28 | 6 | 65 | 30 | Dis.1 |
| BL 32-8 | 32 | 28 | 8 | 65 | 30 | Dis.1 |
| BL 32-10 | 32 | 28 | 10 | 65 | 30 | Dis.1 |
| BL 32-12 | 32 | 28 | 12 | 65 | 30 | Dis.1 |
| BL 32-14 | 32 | 28 | 14 | 65 | 30 | Dis.1 |
| BL 32-16 | 32 | 28 | 16 | 65 | 30 | Dis.1 |

| | | | | | | |
|----------|----|----|----|----|----|-------|
| BL 32-18 | 32 | 38 | 18 | 65 | 30 | Dis.2 |
|----------|----|----|----|----|----|-------|

| | | | | | | |
|----------|----|----|----|----|----|-------|
| BL 32-20 | 32 | 38 | 20 | 65 | 30 | Dis.2 |
|----------|----|----|----|----|----|-------|

| | | | | | | |
|----------|----|----|----|----|----|-------|
| BL 32-25 | 32 | 43 | 25 | 65 | 30 | Dis.3 |
|----------|----|----|----|----|----|-------|

D=50 mm

| ARTICOLO-ITEM | D1 h7 | D2 | d H7 | L | L1 | Rif.-Ref. |
|---------------|-------|----|------|----|----|-----------|
| BL 50-12 | 50 | 40 | 12 | 65 | 30 | Dis.1 |
| BL 50-14 | 50 | 40 | 14 | 65 | 30 | Dis.1 |
| BL 50-16 | 50 | 40 | 16 | 65 | 30 | Dis.1 |
| BL 50-18 | 50 | 40 | 18 | 65 | 30 | Dis.1 |
| BL 50-20 | 50 | 40 | 20 | 65 | 30 | Dis.1 |
| BL 50-25 | 50 | 40 | 25 | 65 | 30 | Dis.1 |

| | | | | | | |
|----------|----|----|----|----|----|-------|
| BL 50-32 | 50 | 56 | 32 | 65 | 30 | Dis.2 |
|----------|----|----|----|----|----|-------|

| | | | | | | |
|----------|----|----|----|----|----|-------|
| BL 50-40 | 50 | 56 | 40 | 65 | 30 | Dis.3 |
|----------|----|----|----|----|----|-------|

BUSSOLE ELASTICHE

ELASTIC BUSHES

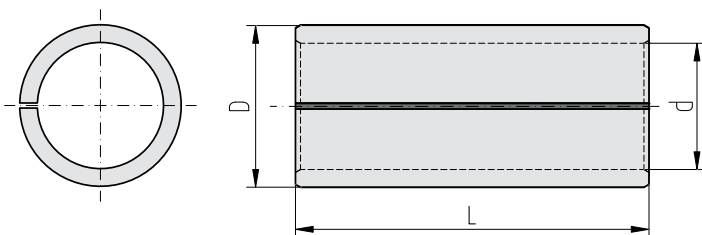

| ARTICOLO-ITEM | D h7 | d H7 | L |
|---------------|------|------|----|
| BE-16-12-40 | 16 | 12 | 40 |
| BE-20-16-50 | 20 | 16 | 50 |
| BE-25-20-60 | 25 | 20 | 60 |
| BE-32-25-70 | 32 | 25 | 70 |
| BE-40-32-80 | 40 | 32 | 80 |
| BE-50-40-90 | 50 | 40 | 90 |



BUSSOLE ELASTICHE PER BARRE ANTIVIBRANTI

ELASTIC BUSHES FOR VIBRATION DAMPER BARS

I Questo tipo di bussola è stata studiata per eliminare le vibrazioni dell'utensile inserito nella bussola durante la lavorazione. Una speciale gomma antivibrante viene inserita nelle fessure "A" e "B" allo scopo di ammortizzare le vibrazioni che crea l'utensile durante la lavorazione in fori profondi.

GB This kind of bush has been developed to eliminate every vibration caused by the tool during the machining. "A" and "B" slots are filled with a special rubber in order to dampen the vibrations the tool creates when it works in deep holes.

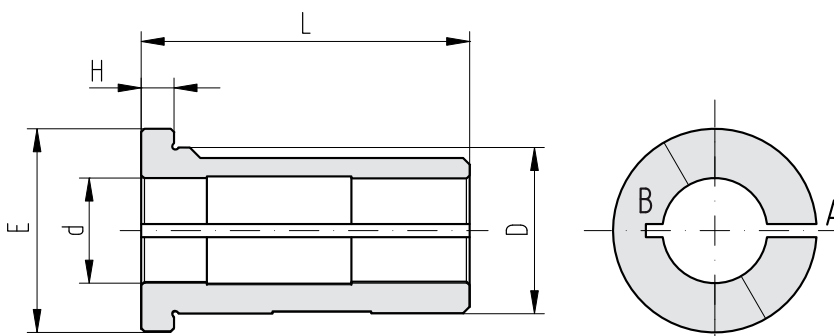

D=25 mm

| ARTICOLO-ITEM | D h6 | d H7 | L | H | E |
|--------------------|------|------|----|---|----|
| BG 25-8-50 | 25 | 8 | 50 | 5 | 31 |
| BG 25-10-50 | 25 | 10 | 50 | 5 | 31 |
| BG 25-12-50 | 25 | 12 | 50 | 5 | 31 |
| BG 25-16-50 | 25 | 16 | 50 | 5 | 31 |
| BG 25-20-50 | 25 | 20 | 50 | 5 | 31 |

D=32 mm

| ARTICOLO-ITEM | D h6 | d H7 | L | H | E |
|--------------------|------|------|----|---|----|
| BG 32-8-60 | 32 | 8 | 60 | 5 | 39 |
| BG 32-10-60 | 32 | 10 | 60 | 5 | 39 |
| BG 32-12-60 | 32 | 12 | 60 | 5 | 39 |
| BG 32-16-60 | 32 | 16 | 60 | 5 | 39 |
| BG 32-20-60 | 32 | 20 | 60 | 5 | 39 |
| BG 32-25-60 | 32 | 25 | 60 | 5 | 39 |

D=40 mm

| ARTICOLO-ITEM | D h6 | d H7 | L | H | E |
|--------------------|------|------|----|---|----|
| BG 40-8-75 | 40 | 8 | 75 | 5 | 48 |
| BG 40-10-75 | 40 | 10 | 75 | 5 | 48 |
| BG 40-12-75 | 40 | 12 | 75 | 5 | 48 |
| BG 40-16-75 | 40 | 16 | 75 | 5 | 48 |
| BG 40-20-75 | 40 | 20 | 75 | 5 | 48 |
| BG 40-25-75 | 40 | 25 | 75 | 5 | 48 |
| BG 40-32-75 | 40 | 32 | 75 | 5 | 48 |



DISEGNO PER ORDINI DI BUSSOLE SPECIALI TECHNICAL DRAWING FOR ORDERING SPECIAL BUSHES

I Se siete interessati a bussole speciali non comprese nel presente Catalogo, inviateci questa pagina debitamente compilata; sarà nostra cura servirVi al meglio e con la massima tempestività.

GB If you are interested in special bushes, not included in this Catalogue, please fill this page in and send it to us: we shall do our best to provide you with prompt efficient service.

BRIGHETTI MECCANICA S.r.L. Tel./Phone: 0039 51 728168 Fax: 0039 51 6463514 E.mail: info@brighetti.it
 Società/Company: _____ Indirizzo/Address: _____
 Tel/Phone: _____ Fax: _____ E-mail: _____
 Q.tà/Q.ty: _____

BUSSOLE CILINDRICHE CYLINDRICAL BUSHES

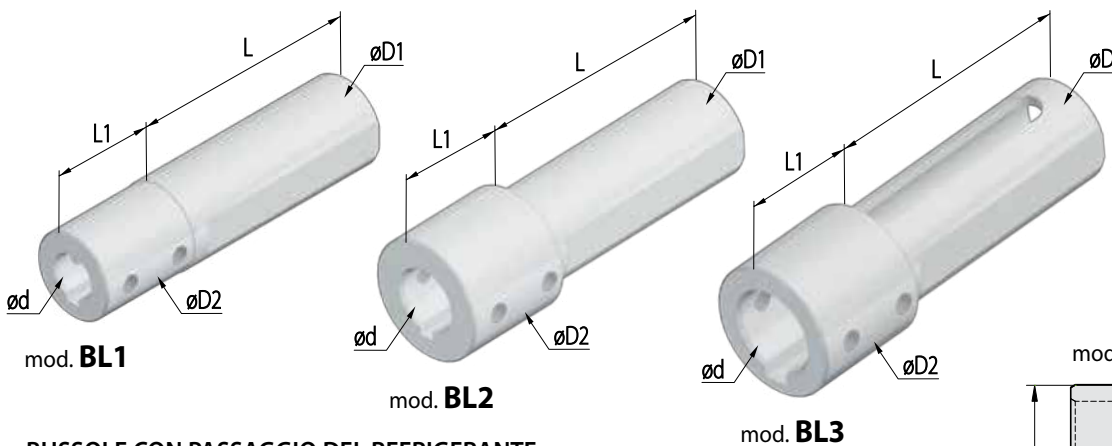
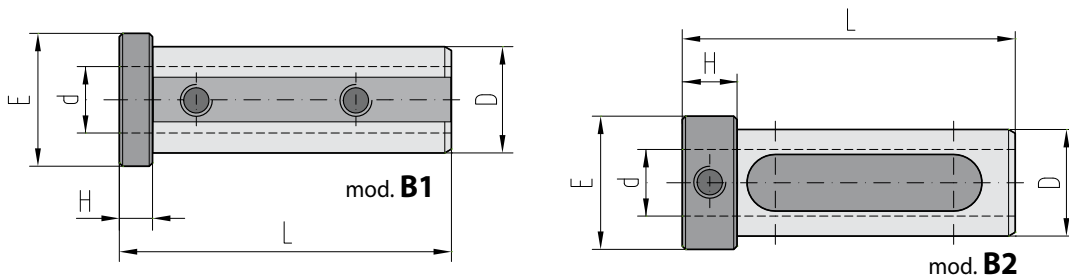

BUSSOLE CON PASSAGGIO DEL REFRIGERANTE BUSHES WITH FLOW OF COOLING LIQUID

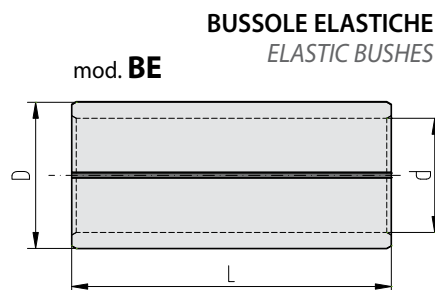

BUSSOLE CONICHE CONICAL BUSHES

BUSSOLE ELASTICHE PER BARRE ANTIVIBRANTI ELASTIC BUSHES FOR VIBRATION DAMPER BARS

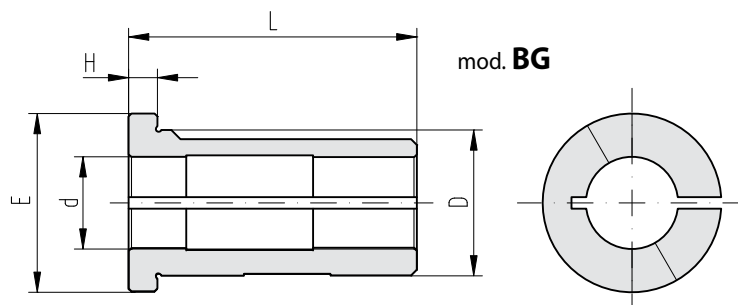
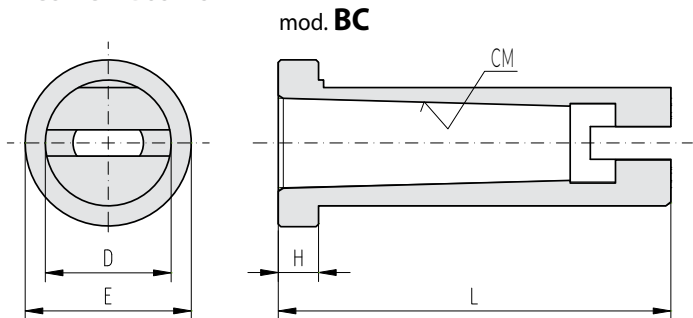

| mod. | d | L | L1 | H | E | D | D1 | D2 | CM |
|------|---|---|----|---|---|---|----|----|----|
| | | | | | | | | | |

Compilare la tabella, scegliendo il modello di Bussola di riduzione a cui si è interessati con la sua relativa sigla.

Compilare poi manualmente il resto della tabella indicando le quote da ottenere

Fill in the table, choosing the type of reduction Bush you are interested in with its relative code, then fill in manually and indicate the dimensions to obtain



Bride di trascinamento

Grinding carriers



I Le Bride di trascinamento a bloccaggio rapido servono per il trascinamento del pezzo da lavorare quando è fissato fra le due punte della macchina utensile.

Il loro impiego risulta molto vantaggioso nelle lavorazioni di rettifica in serie; infatti con la loro rapidità di apertura e chiusura si riduce notevolmente il tempo di sostituzione del pezzo in macchina, con conseguenti risparmi economici.

Vengono prodotte in acciaio e in una vasta gamma di misure.

Ne viene prodotta anche una versione in alluminio, più leggera, e per piccole misure.

GB The fast clamp grinding carriers are used to pull the work piece when it is fixed between two drills.

They are highly useful in mass grinding processes; in fact their high speed opening and closing allows a significant reduction in the time necessary for changing the piece on the machine tool, which also means cost savings.

They are made in steel, in a wide range of sizes.

A version in aluminium is also available, lighter, for small sizes.

BRIDE DI TRASCINAMENTO IN ACCIAIO

GRINDING CARRIERS IN STEEL

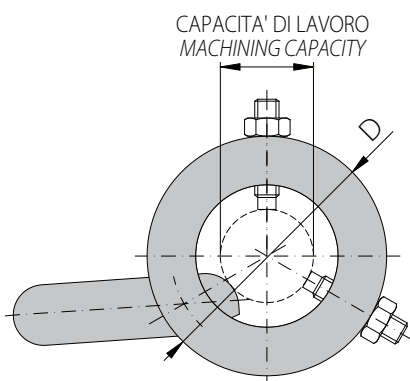

| ARTICOLO-ITEM | D | CAPACITA' DI LAVORO (mm) MACHINING CAPACITY (mm) | LEVA / LEVER | MOLLA / SPRING |
|-------------------|-----|---|-----------------|-------------------|
| BRI-0008 | 33 | da/from 00 a/to 08 | L0008 | M0016 |
| BRI-0816 | 45 | da/from 08 a/to 16 | L0816 | M0016 |
| BRI-1624 | 56 | da/from 16 a/to 24 | L1632 | M1632 |
| BRI-2432 | 65 | da/from 24 a/to 32 | L1632 | M1632 |
| BRI-3240 | 79 | da/from 32 a/to 40 | L3240 | M32120 |
| BRI-4048 | 90 | da/from 40 a/to 48 | L4048 | M32120 |
| BRI-4856 | 102 | da/from 48 a/to 56 | L48120 | M32120 |
| BRI-5664 | 110 | da/from 56 a/to 64 | L48120 | M32120 |
| BRI-6472 | 118 | da/from 64 a/to 72 | L48120 | M32120 |
| BRI-7280 | 126 | da/from 72 a/to 80 | L48120 | M32120 |
| BRI-8090 | 138 | da/from 80 a/to 90 | L48120 | M32120 |
| BRI-90100 | 148 | da/from 90 a/to 100 | L48120 | M32120 |
| BRI-100110 | 158 | da/from 100 a/to 110 | L48120 | M32120 |
| BRI-110120 | 168 | da/from 110 a/to 120 | L48120 | M32120 |



BRIDE DI TRASCINAMENTO IN ALLUMINIO

GRINDING CARRIERS IN ALUMINIUM

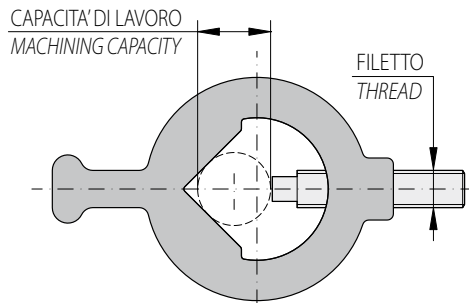

| ARTICOLO-ITEM | FILETTO THREAD | CAPACITA' DI LAVORO (mm) MACHINING CAPACITY (mm) |
|------------------|-------------------|---|
| BRIL-0205 | M4x30 | da/from 2 a/to 5 |
| BRIL-0610 | M5x30 | da/from 6 a/to 10 |
| BRIL-1116 | M5x30 | da/from 11 a/to 16 |
| BRIL-1725 | M8x35 | da/from 17 a/to 25 |

LEVE PER BRIDE

LEVERS FOR GRINDING CARRIERS



| ARTICOLO-ITEM | CAPACITA' DI LAVORO (mm) MACHINING CAPACITY (mm) |
|---------------|---|
| L0008 | da/from 0 a/to 8 |
| L0816 | da/from 8 a/to 16 |
| L1632 | da/from 16 a/to 32 |
| L3240 | da/from 32 a/to 40 |
| L4048 | da/from 40 a/to 48 |
| L48120 | da/from 48 a/to 120 |

MOLLE PER BRIDE

SPRINGS FOR GRINDING CARRIERS



| ARTICOLO-ITEM | CAPACITA' DI LAVORO (mm) MACHINING CAPACITY (mm) |
|---------------|---|
| M0016 | da/from 0 a/to 16 |
| M1632 | da/from 16 a/to 32 |
| M32120 | da/from 32 a/to 120 |





BRIGHETTI MECCANICA

**Via Candini, 3
40012 Calderara di Reno (BO)
tel +39 051 728168 r.a.
fax +39 051 6463514
email: info@brighetti.it
www.brighettibroaching.com**